



RLDRAM 3

IS49RL18320A-2 Meg x 18 x 16 Banks

IS49RL36160A-1 Meg x 36 x 16 Banks

Features

- 1200 MHz DDR operation (2400 Mb/s/ball data rate)
- Organization
 - 32 Meg x 18, and 16 Meg x 36 common I/O (CIO)
 - 16 banks
- 1.2V center-terminated push/pull I/O
- 2.5V V_{EXT} , 1.35V V_{DD} , 1.2V V_{DDQ} (optional 1.35V V_{DDQ} for 2400 operation only).
- Reduced cycle time (t_{RC} (MIN) = 6.67 - 8ns)
- SDR addressing
- Programmable READ/WRITE latency (RL/WL) and burst length
- Data mask for WRITE commands
- Differential input clocks (CK, CK#)
- Free-running differential input data clocks (DK x, DK x#) and output data clocks (QK x, QK x#)
- On-die DLL generates CK edge-aligned data and differential output data clock signals
- 64ms refresh (128K refresh per 64ms)
- 40 Ω or 60 Ω matched impedance outputs
- Integrated on-die termination (ODT)
- Single or multibank writes
- Extended operating range (200–1200 MHz)
- READ training register
- Multiplexed and non-multiplexed addressing capabilities
- Mirror function
- Output driver and ODT calibration
- Post Package Repair - 1 row per half bank
- JTAG interface (IEEE 1149.1-2001)

Options

- Clock cycle and t_{RC} timing
 - 0.83ns and t_{RC} (MIN) = 6.67ns (RL3-2400) for -083F
 - 0.83ns and t_{RC} (MIN) = 7.5ns (RL3-2400) for -083E
 - 0.93ns and t_{RC} (MIN) = 7.5ns (RL3-2133) for -093F
 - 0.93ns and t_{RC} (MIN) = 8.0ns (RL3-2133) for -093E
 - 1.07ns and t_{RC} (MIN) = 8.0ns (RL3-1866) for -107E
- Configuration
 - 32 Meg x 18
 - 16 Meg x 36
- Operating Temperature
 - Commercial ($T_C = 0^\circ$ to $+95^\circ\text{C}$)
 - Industrial ($T_C = -40^\circ\text{C}$ to $+95^\circ\text{C}$)
- Package
 - 168-ball FBGA (Green)

Copyright © 2024 Integrated Silicon Solution, Inc. All rights reserved. ISSI reserves the right to make changes to this specification and its products at any time without notice. ISSI assumes no liability arising out of the application or use of any information, products or services described herein. Customers are advised to obtain the latest version of this device specification before relying on any published information and before placing orders for products.

Integrated Silicon Solution, Inc. does not recommend the use of any of its products in life support applications where the failure or malfunction of the product can reasonably be expected to cause failure of the life support system or to significantly affect its safety or effectiveness. Products are not authorized for use in such applications unless Integrated Silicon Solution, Inc. receives written assurance to its satisfaction, that:

- a.) the risk of injury or damage has been minimized;
- b.) the user assume all such risks; and
- c.) potential liability of Integrated Silicon Solution, Inc is adequately protected under the circumstances

RLDRAM® is a registered trademark of Micron Technology, Inc.



Figure 1: 576Mb RLD RAM[®] 3 Part Numbers

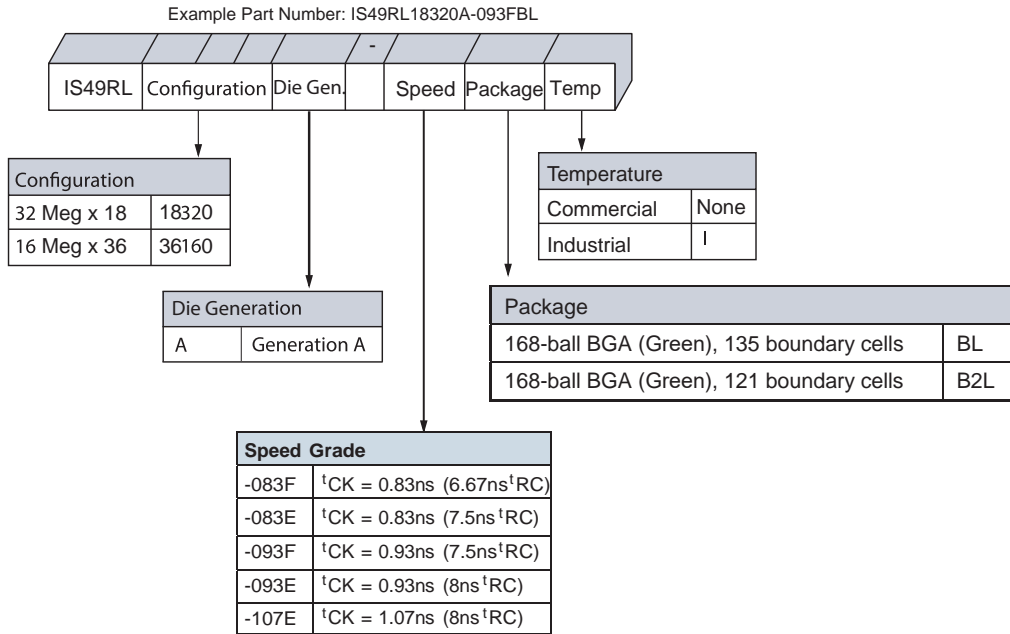



Contents

General Description	9
General Notes	9
State Diagram	10
Functional Block Diagrams	11
Ball Assignments and Descriptions	13
Electrical Characteristics – I _{DD} Specifications	17
Electrical Specifications – Absolute Ratings and I/O Capacitance	20
Absolute Maximum Ratings	20
Input/Output Capacitance	21
AC and DC Operating Conditions	22
AC Overshoot/Undershoot Specifications	23
Slew Rate Definitions for Single-Ended Input Signals	27
Slew Rate Definitions for Differential Input Signals	29
ODT Characteristics	30
ODT Resistors	30
ODT Sensitivity	32
Output Driver Impedance	33
Output Driver Sensitivity	35
Output Characteristics and Operating Conditions	36
Reference Output Load	39
Slew Rate Definitions for Single-Ended Output Signals	40
Slew Rate Definitions for Differential Output Signals	41
Speed Bin Tables	42
AC Electrical Characteristics	43
Temperature and Thermal Impedance Characteristics	49
Command and Address Setup, Hold, and Derating	51
Data Setup, Hold, and Derating	58
Commands	65
MODE REGISTER SET (MRS) Command	66
Mode Register 0 (MR0)	67
^t RC	68
Data Latency	68
DLL Enable/Disable	68
Address Multiplexing	69
Mode Register 1 (MR1)	70
Output Drive Impedance	70
DQ On-Die Termination (ODT)	71
DLL Reset	71
ZQ Calibration	71
ZQ Calibration Long	72
ZQ Calibration Short	72
AUTO REFRESH Protocol	73
Burst Length (BL)	73
Mode Register 2 (MR2)	73
READ Training Register (RTR)	75
WRITE Protocol	76
WRITE Command	76
Multibank WRITE	76
Post Package Repair – PPR	79
PPR Row Repair Sequence	79
READ Command	81



AUTO REFRESH Command	81
INITIALIZATION Operation	84
WRITE Operation	87
READ Operation	91
AUTO REFRESH Operation	94
RESET Operation	97
Mirror Function	99
Multiplexed Address Mode	100
Data Latency in Multiplexed Address Mode	105
REFRESH Command in Multiplexed Address Mode	105
IEEE 1149.1 Serial Boundary Scan (JTAG)	109
Disabling the JTAG Feature	109
Test Access Port (TAP)	109
TAP Controller	110
Performing a TAP RESET	112
TAP Registers	112
TAP Instruction Set	113
Ordering Information	121
Package Dimensions	122



List of Figures

Figure 1: 576Mb RLD RAM [®] 3 Part Numbers	2
Figure 2: Simplified State Diagram	10
Figure 3: 32 Meg x 18 Functional Block Diagram	11
Figure 4: 16 Meg x 36 Functional Block Diagram	13
Figure 5: Single-Ended Input Signal	22
Figure 6: Overshoot	23
Figure 7: Undershoot	23
Figure 8: V _{IX} for Differential Signals	24
Figure 9: Single-Ended Requirements for Differential Signals	25
Figure 10: Definition of Differential AC Swing and ^t DVAC	26
Figure 11: Nominal Slew Rate Definition for Single-Ended Input Signals	27
Figure 12: Nominal Slew Rate Definition for Single-Ended Input Signals	27
Figure 13: Nominal Differential Input Slew Rate Definition for CK, CK#, DKx, and DKx#	28
Figure 14: ODT Levels and I-V Characteristics	29
Figure 15: Output Driver	3 2
Figure 16: DQ Output Signal	37
Figure 17: Differential Output Signal	38
Figure 18: Reference Output Load for AC Timing and Output Slew Rate	38
Figure 19: Nominal Slew Rate Definition for Single-Ended Output Signals	39
Figure 20: Nominal Differential Output Slew Rate Definition for QKx, QKx#	40
Figure 21: Example Temperature Test Point Location	49
Figure 22: Nominal Slew Rate and ^t VAC for ^t IS (Command and Address - Clock)	53
Figure 23: Nominal Slew Rate for ^t IH (Command and Address - Clock)	54
Figure 24: Tangent Line for ^t IS (Command and Address - Clock)	55
Figure 25: Tangent Line for ^t IH (Command and Address - Clock)	56
Figure 26: Nominal Slew Rate and ^t VAC for ^t DS (DQ - Strobe)	60
Figure 27: Nominal Slew Rate for ^t DH (DQ - Strobe)	61
Figure 28: Tangent Line for ^t DS (DQ - Strobe)	62
Figure 29: Tangent Line for ^t DH (DQ - Strobe)	63
Figure 30: MRS Command Protocol	65
Figure 31: MR0 Definition for Non-Multiplexed Address Mode	66
Figure 32: MR1 Definition for Non-Multiplexed Address Mode	69
Figure 33: ZQ Calibration Timing (ZQCL and ZQCS)	71
Figure 34: Read Burst Lengths	73
Figure 35: MR2 Definition for Non-Multiplexed Address Mode	74
Figure 36: READ Training Function - Back-to-Back Readout	76
Figure 37: WRITE Command	77
Figure 38: Entry, Repair, and Exit Timing Diagram	80
Figure 39: READ Command	81
Figure 40: Bank Address-Controlled AUTO REFRESH Command	82
Figure 41: Multibank AUTO REFRESH Command	83
Figure 42: Power-Up/Initialization Sequence	85
Figure 43: WRITE Burst	87
Figure 44: Consecutive WRITE Bursts	88
Figure 45: WRITE-to-READ	88
Figure 46: WRITE - DM Operation	89
Figure 47: Consecutive Quad Bank WRITE Bursts	90
Figure 48: Interleaved READ and Quad Bank WRITE Bursts	90
Figure 49: Basic READ Burst	91
Figure 50: Consecutive READ Bursts (BL = 2)	92
Figure 51: Consecutive READ Bursts (BL = 4)	92



Figure 52: READ-to-WRITE (BL = 2) 93
Figure 53: Read Data Valid Window 93
Figure 54: Bank Address-Controlled AUTO REFRESH Cycle 94
Figure 55: Multibank AUTO REFRESH Cycle 94
Figure 56: READ Burst with ODT 95
Figure 57: READ-NOP-READ with ODT 96
Figure 58: Reset Sequence 99
Figure 59: Command Description in Multiplexed Address Mode 100
Figure 60: Power-Up/Initialization Sequence in Multiplexed Address Mode101
Figure 61: MR0 Definition for Multiplexed Address Mode 102
Figure 62: MR1 Definition for Multiplexed Address Mode 103
Figure 63: MR2 Definition for Multiplexed Address Mode 104
Figure 64: Bank Address-Controlled AUTO REFRESH Operation with Multiplexed Addressing 105
Figure 65: Multibank AUTO REFRESH Operation with Multiplexed Addressing 106
Figure 66: Consecutive WRITE Bursts with Multiplexed Addressing 106
Figure 67: WRITE-to-READ with Multiplexed Addressing 107
Figure 68: Consecutive READ Bursts with Multiplexed Addressing 107
Figure 69: READ-to-WRITE with Multiplexed Addressing 108
Figure 70: TAP Controller State Diagram 111
Figure 71: TAP Controller Functional Block Diagram 111
Figure 72: JTAG Operation - Loading Instruction Code and Shifting Out Data 114
Figure 73 TAP Timing 115
Figure 73 Package Dimensions 120



List of Tables

Table 1: 32 Meg x 18 Ball Assignments – 168-Ball FBGA (Top View) 13

Table 2: 16 Meg x 36 Ball Assignments – 168-Ball FBGA (Top View) 14

Table 3: Ball Descriptions 15

Table 4: I_{DD} Operating Conditions and Maximum Limits..... 17

Table 5: Absolute Maximum Ratings 20

Table 6: Input/Output Capacitance 21

Table 7: DC Electrical Characteristics and Operating Conditions..... 22

Table 8: Input AC Logic Levels 22

Table 9: Control and Address Balls 23

Table 10: Clock, Data, Strobe, and Mask Balls 24

Table 11: Differential Input Operating Conditions (CK, CK# and DKx, DKx#) 25

Table 12: Allowed Time Before Ringback (^tDVAC) for CK, CK#, DKx, and DKx# 27

Table 13: Single-Ended Input Slew Rate Definition 27

Table 14: Differential Input Slew Rate Definition 29

Table 15: ODT DC Electrical Characteristics 30

Table 16: R_{TT} Effective Impedances 31

Table 17: ODT Sensitivity Definition 32

Table 18: ODT Temperature and Voltage Sensitivity 32

Table 19: Driver Pull-Up and Pull-Down Impedance Calculations 34

Table 20: Output Driver Sensitivity Definition 35

Table 21: Output Driver Voltage and Temperature Sensitivity 35

Table 22: Single-Ended Output Driver Characteristics 36

Table 23: Differential Output Driver Characteristics 37

Table 24: Single-Ended Output Slew Rate Definition 40

Table 25: Differential Output Slew Rate Definition 41

Table 26: RL3 Speed Bins 42

Table 27: AC Electrical Characteristics 43

Table 28: Temperature Limits 49

Table 29: Thermal Impedance 50

Table 30: Command and Address Setup and Hold Values Referenced at 1 V/ns – AC/DC-Based 51

Table 31: Derating Values for ^tIS/ ^tIH – AC150/DC100-Based 52

Table 32: Derating Values for ^tIS/^tIH – AC135/DC100-Based 52

Table 33: Derating Values for ^tIS/^tIH – AC120/DC100-Based 53

Table 34: Minimum Required Time ^tVAC Above V_{IH(AC)} (or Below V_{IL(AC)}) for Valid Transition..... 53

Table 35: Data Setup and Hold Values at 1 V/ns (DKx, DKx# at 2V/ns) – AC/DC-Based 58

Table 36: Derating Values for ^tDS/ ^tDH – AC150/DC100-Based..... 59

Table 37: Derating Values for ^tDS/^tDH – AC135/DC100-Based 59

Table 38: Derating Values for ^tDS/^tDH – AC120/DC100-Based 60

Table 39: Minimum Required Time ^tVAC Above V_{IH(AC)} (or Below V_{IL(AC)}) for Valid Transition..... 60

Table 40: Command Descriptions 65

Table 41: Command Table 65

Table 42: ^tRC_MRS MR0[3:0] values 68

Table 43: Address Widths of Different Burst Lengths..... 73

Table 44: RLD RAM3 PPR Timing Parameters 79

Table 45: 64 Meg x 18 Ball Assignments with MF Ball Tied HIGH 99

Table 46: Address Mapping in Multiplexed Address Mode 104

Table 47: TAP Input AC Logic Levels 115

Table 48: TAP AC Electrical Characteristics 115

Table 49: TAP DC Electrical Characteristics and Operating Conditions..... 116

Table 50: Scan Register Sizes 116



Table 51: Instruction Codes	117
Table 52: Identification Register Definitions	117
Table 53: MR0_MR1 Mode Register Settings	117
Table 54: MR2 Mode Register Settings	118
Table 55: Boundary Scan (Exit)	119
Table 56: Ordering information	120



General Description

The ISSI® RLD RAM® 3 is a high-speed memory device designed for high-bandwidth data storage—telecommunications, networking, cache applications, and so forth. The chip's 16-bank architecture is optimized for sustainable high-speed operation.

The DDR I/O interface transfers two data bits per clock cycle at the I/O balls. Output data is referenced to the READ strobes.

Commands, addresses, and control signals are also registered at every positive edge of the differential input clock, while input data is registered at both positive and negative edges of the input data strobes.

Read and write accesses to the RL3 device are burst-oriented. The burst length (BL) is programmable to 2, 4, or 8 by a setting in the mode register.

The device is supplied with 1.35V for the core and 1.2V for the output drivers. The 2.5V supply is used for an internal supply.

Bank-scheduled refresh is supported with the row address generated internally.

The 168-ball BGA package is used to enable ultra-high-speed data transfer rates.

General Notes

- The functionality and the timing specifications discussed in this data sheet are for the DLL enable mode of operation.
- Any functionality not specifically stated is considered undefined, illegal, and not supported, and can result in unknown operation.
- Nominal conditions are assumed for specifications not defined within the figures shown in this data sheet.
- Throughout this data sheet, the terms "RLDRAM," "DRAM," and "RLDRAM 3" are all used interchangeably and refer to the RLD RAM 3 SDRAM device.
- References to DQ, DK, QK, DM, and QVLD are to be interpreted as each group collectively, unless specifically stated otherwise. This includes true and complement signals of differential signals.
- Non-multiplexed operation is assumed if not specified as multiplexed.
- A x36 device supplies four QK/QK# sets, one per nine DQ. Using only two QK/QK# sets is allowed, but QK0/QK0# and QK1/QK1# must be used. QK0/QK0# control DQ[8:0] and DQ[26:18], and QK1/QK1# control DQ[17:9] and DQ[35:27]. The QK to DQ timing parameter to be used is ^tQKQ02, ^tQKQ13. The unused QK/QK# pins should be left floating.

State Diagram

Figure 2: Simplified State Diagram

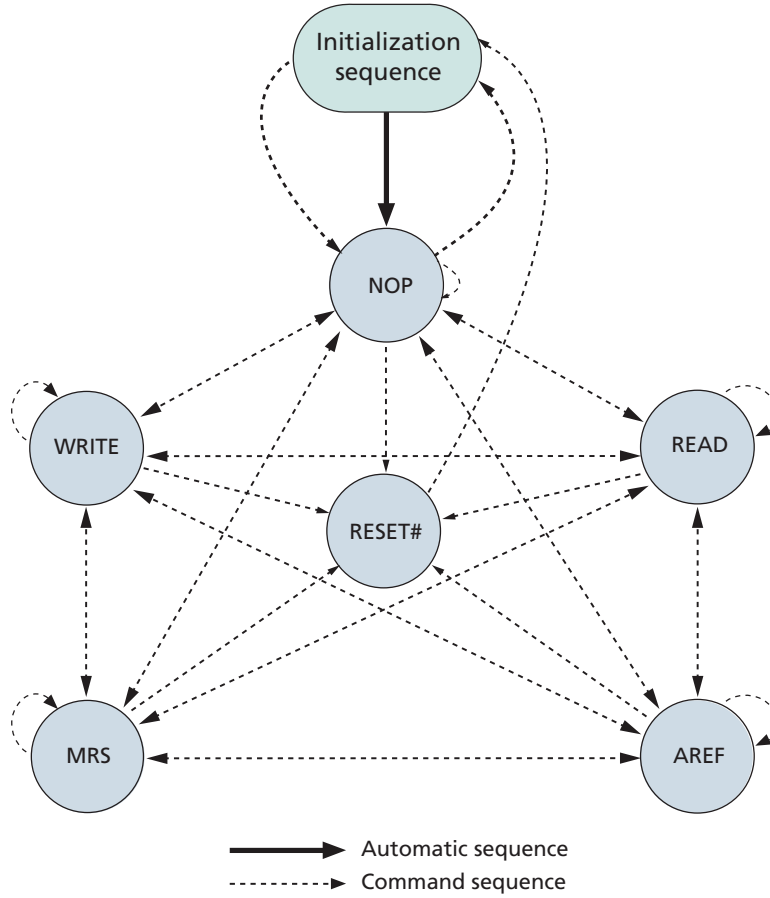
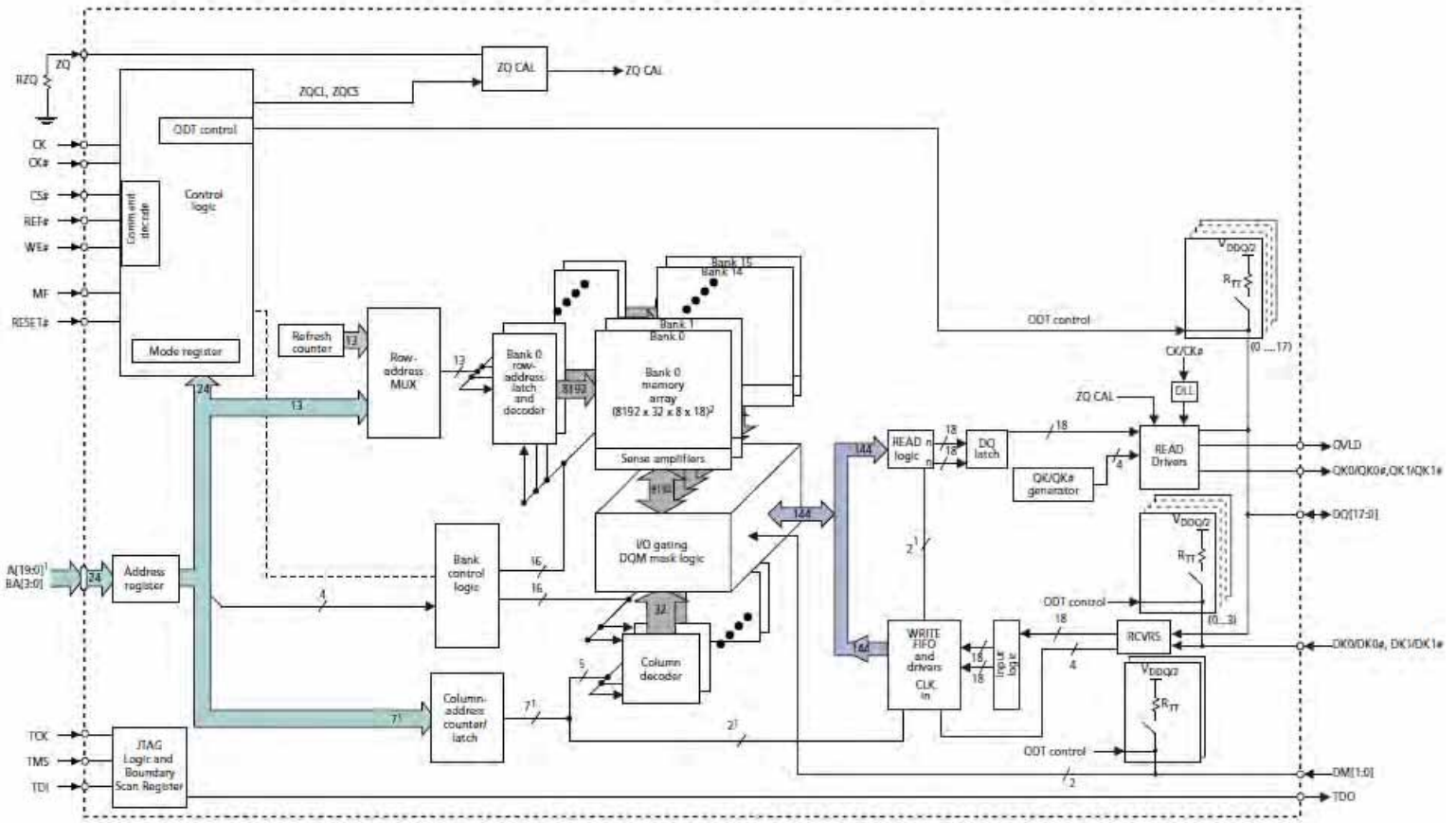
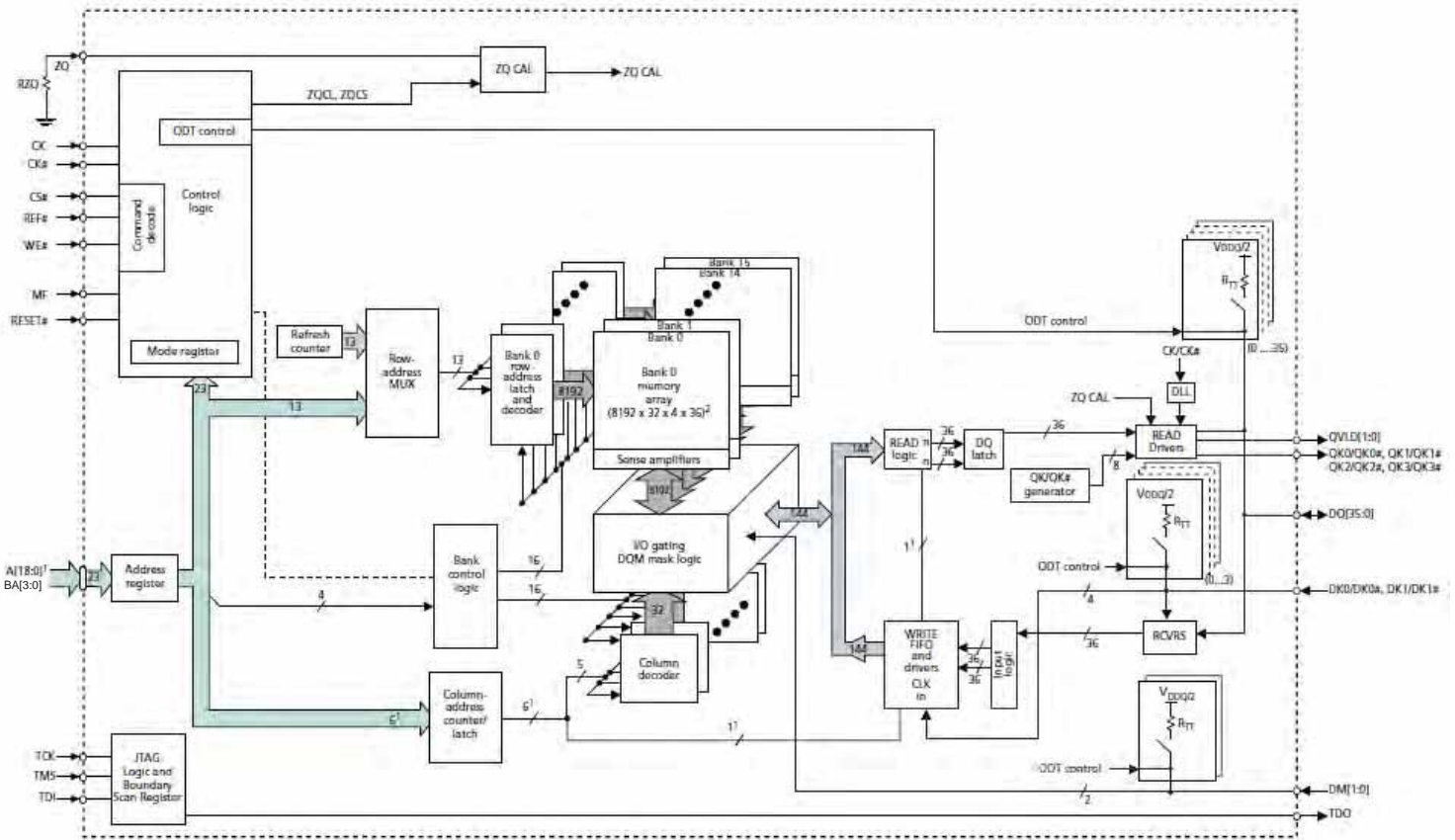

Figure 3: 32 Meg x 18 Functional Block Diagram



- Notes:
1. Example for BL = 2; column address will be reduced with an increase in burst length.
 2. $8 = (\text{length of burst}) \times 2^{\wedge} (\text{number of column addresses to WRITE FIFO and READ logic})$.

Figure 4: 16 Meg x36 Functional Block Diagram



- Notes:
1. Example for BL = 2; column address will be reduced with an increase in burst length.
 2. $4 = (\text{length of burst}) \times 2^{\text{(number of column addresses to WRITE FIFO and READ logic)}}$



Ball Assignments and Descriptions

Table 1: 32 Meg x 18 Ball Assignments – 168-Ball BGA (Top View)

	1	2	3	4	5	6	7	8	9	10	11	12	13
A		V _{SS}	V _{DD}	NF	V _{DDQ}	NF	V _{REF}	DQ7	V _{DDQ}	DQ8	V _{DD}	V _{SS}	RESET#
B	V _{EXT}	V _{SS}	NF	V _{SSQ}	NF	V _{DDQ}	DM0	V _{DDQ}	DQ5	V _{SSQ}	DQ6	V _{SS}	V _{EXT}
C	V _{DD}	NF	V _{DDQ}	NF	V _{SSQ}	NF	DK0#	DQ2	V _{SSQ}	DQ3	V _{DDQ}	DQ4	V _{DD}
D	A11	V _{SSQ}	NF	V _{DDQ}	NF	V _{SSQ}	DK0	V _{SSQ}	QK0	V _{DDQ}	DQ0	V _{SSQ}	A13
E	V _{SS}	A0	V _{SSQ}	NF	V _{DDQ}	NF	MF	QK0#	V _{DDQ}	DQ1	V _{SSQ}	CS#	V _{SS}
F	A7	NF	V _{DD}	A2	A1	WE#	ZQ	REF#	A3	A4	V _{DD}	A5	A9
G	V _{SS}	A15	A6	V _{SS}	BA1	V _{SS}	CK#	V _{SS}	BA0	V _{SS}	A8	A18	V _{SS}
H	A19	V _{DD}	A14	A16	V _{DD}	BA3	CK	BA2	V _{DD}	A17	A12	V _{DD}	A10
J	V _{DDQ}	NF	V _{SSQ}	NF	V _{DDQ}	NF	V _{SS}	QK1#	V _{DDQ}	DQ9	V _{SSQ}	QVLD	V _{DDQ}
K	NF	V _{SSQ}	NF	V _{DDQ}	NF	V _{SSQ}	DK1	V _{SSQ}	QK1	V _{DDQ}	DQ10	V _{SSQ}	DQ11
L	V _{DD}	NF	V _{DDQ}	NF	V _{SSQ}	NF	DK1#	DQ12	V _{SSQ}	DQ13	V _{DDQ}	DQ14	V _{DD}
M	V _{EXT}	V _{SS}	NF	V _{SSQ}	NF	V _{DDQ}	DM1	V _{DDQ}	DQ15	V _{SSQ}	DQ16	V _{SS}	V _{EXT}
N	V _{SS}	TCK	V _{DD}	TDO	V _{DDQ}	NF	V _{REF}	DQ17	V _{DDQ}	TDI	V _{DD}	TMS	V _{SS}

Notes:

1. NF balls for the x18 configuration are internally connected and have parasitic characteristics of an I/O. Balls may be connected to V_{SSQ}.
2. MF is assumed to be tied LOW for this ball assignment.



Table 2:16 Meg x 36 Ball Assignments – 168-Ball BGA (Top View)

	1	2	3	4	5	6	7	8	9	10	11	12	13
A		V _{SS}	V _{DD}	DQ26	V _{DDQ}	DQ25	V _{REF}	DQ7	V _{DDQ}	DQ8	V _{DD}	V _{SS}	RESET#
B	V _{EXT}	V _{SS}	DQ24	V _{SSQ}	DQ23	V _{DDQ}	DM0	V _{DDQ}	DQ5	V _{SSQ}	DQ6	V _{SS}	V _{EXT}
C	V _{DD}	DQ22	V _{DDQ}	DQ21	V _{SSQ}	DQ20	DK0#	DQ2	V _{SSQ}	DQ3	V _{DDQ}	DQ4	V _{DD}
D	A11	V _{SSQ}	DQ18	V _{DDQ}	QK2	V _{SSQ}	DK0	V _{SSQ}	QK0	V _{DDQ}	DQ0	V _{SSQ}	A13
E	V _{SS}	A0	V _{SSQ}	DQ19	V _{DDQ}	QK2#	MF	QK0#	V _{DDQ}	DQ1	V _{SSQ}	CS#	V _{SS}
F	A7	NF	V _{DD}	A2	A1	WE#	ZQ	REF#	A3	A4	V _{DD}	A5	A9
G	V _{SS}	A15	A6	V _{SS}	BA1	V _{SS}	CK#	V _{SS}	BA0	V _{SS}	A8	A18	V _{SS}
H	NF	V _{DD}	A14	A16	V _{DD}	BA3	CK	BA2	V _{DD}	A17	A12	V _{DD}	A10
J	V _{DDQ}	QVLD1	V _{SSQ}	DQ27	V _{DDQ}	QK3#	V _{SS}	QK1#	V _{DDQ}	DQ9	V _{SSQ}	QVLD0	V _{DDQ}
K	DQ29	V _{SSQ}	DQ28	V _{DDQ}	QK3	V _{SSQ}	DK1	V _{SSQ}	QK1	V _{DDQ}	DQ10	V _{SSQ}	DQ11
L	V _{DD}	DQ32	V _{DDQ}	DQ31	V _{SSQ}	DQ30	DK1#	DQ12	V _{SSQ}	DQ13	V _{DDQ}	DQ14	V _{DD}
M	V _{EXT}	V _{SS}	DQ34	V _{SSQ}	DQ33	V _{DDQ}	DM1	V _{DDQ}	DQ15	V _{SSQ}	DQ16	V _{SS}	V _{EXT}
N	V _{SS}	TCK	V _{DD}	TDO	V _{DDQ}	DQ35	V _{REF}	DQ17	V _{DDQ}	TDI	V _{DD}	TMS	V _{SS}

Notes:

1. NF ball for x36 configuration is internally connected and has parasitic characteristics of an address. Ball may be connected to V_{SSQ}.
2. MF is assumed to be tied LOW for this ball assignment.



Table 3: Ball Descriptions

Symbol	Type	Description
A[19:0]	Input	Address inputs: A[20:0] define the row and column addresses for READ and WRITE operations. During a MODE REGISTER SET, the address inputs define the register settings along with BA[3:0]. They are sampled at the rising edge of CK.
BA[3:0]	Input	Bank address inputs: Select the internal bank to which a command is being applied.
CK/CK#	Input	Input clock: CK and CK# are differential input clocks. Addresses and commands are latched on the rising edge of CK.
CS#	Input	Chip select: CS# enables the command decoder when LOW and disables it when HIGH. When the command decoder is disabled, new commands are ignored, but internal operations continue.
DQ[35:0]	I/O	Data input: The DQ signals form the 36-bit data bus. During READ commands, the data is referenced to both edges of QK. During WRITE commands, the data is sampled at both edges of DK.
DKx, DKx#	Input	Input data clock: DKx and DKx# are differential input data clocks. All input data is referenced to both edges of DKx. For the x36 device, DQ[8:0] and DQ[26:18] are referenced to DK0 and DK0#, and DQ[17:9] and DQ[35:27] are referenced to DK1 and DK1#. For the x18 device, DQ[8:0] are referenced to DK0 and DK0#, and DQ[17:9] are referenced to DK1 and DK1#. DKx and DKx# are free-running signals and must always be supplied to the device.
DM[1:0]	Input	Input data mask: DM is the input mask signal for WRITE data. Input data is masked when DM is sampled HIGH. DM0 is used to mask the lower byte for the x18 device and DQ[8:0] and DQ[26:18] for the x36 device. DM1 is used to mask the upper byte for the x18 device and DQ[17:9] and DQ[35:27] for the x36 device. Tie DM[1:0] to V _{SS} if not used.
TCK	Input	IEEE 1149.1 clock input: This ball must be tied to V _{SS} if the JTAG function is not used.
TMS, TDI	Input	IEEE 1149.1 test inputs: These balls may be left as no connects if the JTAG function is not used.
WE#, REF#	Input	Command inputs: Sampled at the positive edge of CK, WE# and REF# (together with CS#) define the command to be executed.
RESET#	Input	Reset: RESET# is an active LOW CMOS input referenced to V _{SS} . RESET# assertion and deassertion are asynchronous. RESET# is a CMOS input defined with DC HIGH $\geq 0.8 \times V_{DDQ}$ and DC LOW $\leq 0.2 \times V_{DDQ}$.
ZQ	Input	External impedance: This signal is used to tune the device's output impedance and ODT. RZQ needs to be 240Ω, where RZQ is a resistor from this signal to ground.
QKx, QKx#	Output	Output data clocks: QK and QK# are opposite-polarity output data clocks. They are free-running signals and during READ commands are edge-aligned with the DQs. For the x36 device, QK0, QK0# align with DQ[8:0]; QK1, QK1# align with DQ[17:9]; QK2, QK2# align with DQ[26:18]; QK3, QK3# align with DQ[35:27]. For the x18 device, QK0, QK0# align with DQ[8:0]; QK1, QK1# align with DQ[17:9].
QVLDx	Output	Data valid: The QVLD ball indicates that valid output data will be available on the subsequent rising clock edge. There is a single QVLD ball for the x18 device and two, QVLD0 and QVLD1, for the x36 device. QVLD0 aligns with DQ[17:0]; QVLD1 aligns with DQ[35:18].
MF	Input	Mirror function: The mirror function ball is a DC input used to create mirrored ballouts for simple dual-loaded clamshell mounting. If the ball is tied to V _{SS} , the address and command balls are in their true layout. If the ball is tied to V _{DDQ} , they are in the complement location. MF must be tied HIGH or LOW and cannot be left floating. MF is a CMOS input defined with DC HIGH $\geq 0.8 \times V_{DD}$ and DC LOW $\leq 0.2 \times V_{DDQ}$.



Table 3: Ball Descriptions (Continued)

Symbol	Type	Description
V _{DD}	Supply	Power supply: 1.35V nominal. See AC and DC Operating Conditions (page 23) for range.
V _{DDQ}	Supply	DQ power supply: 1.2V or 1.35V nominal. 1.2V can be used for all speed grades. The 1.35V can only be used for 2400 Mb/s operation if required tp close timing. Isolated on the device for improved noise immunity. See AC and DC Operating Conditions (page 23) for range.
V _{EXT}	Supply	Power supply: 2.5V nominal. See AC and DC Operating Conditions (page 23) for range.
V _{REF}	Supply	Input reference voltage: V _{DDQ} /2 nominal. Provides a reference voltage for the input buffers.
V _{SS}	Supply	Ground.
V _{SSQ}	Supply	DQ ground: Isolated on the device for improved noise immunity.
NC	–	No connect: These balls are not connected to the DRAM.
NF	–	No function: These balls are connected to the DRAM but provide no functionality.



576Mb: x18, x36 RLDRAM 3
Electrical Characteristics – I_{DD} Specifications

Table 4: I_{DD} Operating Conditions and Maximum Limits

Notes 1–6 apply to the entire table

Description	Condition	Symbol	-083F	-083E	-093F	-093E	-107E	Units	Notes
Standby current	t _{CK} = idle; All banks idle; No inputs toggling	I _{SB1} (V _{DD}) x18	TBD	TBD	325	325	325	mA	7
		I _{SB1} (V _{DD}) x36	TBD	TBD	325	325	325		
		I _{SB1} (V _{EXT})	TBD	TBD	5	5	5		
Clock active standby current	CS# = 1; No commands; Bank address incremented and half address/data change once every four clock cycles	I _{SB2} (V _{DD}) x18	TBD	TBD	755	755	630	mA	
		I _{SB2} (V _{DD}) x36	TBD	TBD	770	770	645		
		I _{SB2} (V _{EXT})	TBD	TBD	5	5	5		
Operational current: BL2	BL = 2; Sequential bank access; Bank transitions once every t _{RC} ; Half address transitions once every t _{RC} ; Read followed by write sequence; Continuous data during WRITE commands	I _{DD1} (V _{DD}) x18	TBD	TBD	1255	1255	1015	mA	
		I _{DD1} (V _{DD}) x36	TBD	TBD	1310	1310	1080		
		I _{DD1} (V _{EXT})	TBD	TBD	15	15	15		
Operational current: BL4	BL = 4; Sequential bank access; Bank transitions once every t _{RC} ; Half address transitions once every t _{RC} ; Read followed by write sequence; Continuous data during WRITE commands	I _{DD2} (V _{DD}) x18	TBD	TBD	1270	1270	1040	mA	
		I _{DD2} (V _{DD}) x36	TBD	TBD	1335	1335	1120		
		I _{DD2} (V _{EXT})	TBD	TBD	15	15	15		
Operational current: BL8	BL = 8; Sequential bank access; Bank transitions once every t _{RC} ; Half address transitions once every t _{RC} ; Read followed by write sequence; Continuous data during WRITE commands	I _{DD3} (V _{DD}) x18	TBD	TBD	1270	1270	1040	mA	
		I _{DD3} (V _{DD}) x36	NA	NA	NA	NA	NA		
		I _{DD3} (V _{EXT})	TBD	TBD	15	15	15		
Burst refresh current	Sixteen bank cyclic refresh using Bank Address Control AREF protocol; Command bus remains in refresh for all sixteen banks; DQs are High-Z and at V _{DDQ} /2; Addresses are at V _{DDQ} /2	I _{REF1} (V _{DD}) x18	TBD	TBD	1185	1185	985	mA	
		I _{REF1} (V _{DD}) x36	TBD	TBD	1200	1200	1000		
		I _{REF1} (V _{EXT})	TBD	TBD	80	80	80		



Table 4: I_{DD} Operating Conditions and Maximum Limits (Continued)

Notes 1–6 apply to the entire table

Description	Condition	Symbol	-083F	-083E	-093F	-093E	-107E	Units	Notes
Distributed refresh current	Single bank refresh using Bank Address Control AREF protocol; Sequential bank access every 0.489µs; DQs are High-Z and at V _{DDQ} /2; Addresses are at V _{DDQ} /2	I _{REF2} (V _{DD}) x18	TBD	TBD	710	710	580	mA	
		I _{REF2} (V _{DD}) x36	TBD	TBD	725	725	595		
		I _{REF2} (V _{EXT})	TBD	TBD	5	5	5		
Multibank refresh current: 4 bank refresh	Quad bank refresh using Multi-bank AREF protocol; BL=4; Cyclic bank access; Subject to t _{SAW} and t _{MMD} specifications; DQs are High-Z and at V _{DDQ} /2; Bank addresses are at V _{DDQ} /2	I _{MBREF4} (V _{DD}) x18	TBD	TBD	1185	1185	1040	mA	
		I _{MBREF4} (V _{DD}) x36	TBD	TBD	1200	1200	1055		
		I _{MBREF4} (V _{EXT})	TBD	TBD	30	30	30		
Operating burst write current : BL2	BL = 2; Cyclic bank access; Half of address bits change every clock cycle; Continuous data; Measurement is taken during continuous WRITE	I _{DD2W} (V _{DD}) x18	TBD	TBD	1830	1830	1640	mA	
		I _{DD2W} (V _{DD}) x36	TBD	TBD	1895	1895	1655		
		I _{DD2W} (V _{EXT})	TBD	TBD	80	80	80		
Operating burst write current : BL4	BL = 4; Cyclic bank access; Half of address bits change every two clock cycles; Continuous data; Measurement is taken during continuous WRITE	I _{DD4W} (V _{DD}) x18	TBD	TBD	1880	1880	1630	mA	
		I _{DD4W} (V _{DD}) x36	TBD	TBD	1890	1890	1645		
		I _{DD4W} (V _{EXT})	TBD	TBD	40	40	40		
Operating burst write current :BL8	BL = 8; Cyclic bank access; Half of address bits change every four clock cycles; Continuous data; Measurement is taken during continuous WRITE	I _{DD8W} (V _{DD}) x18	TBD	TBD	1880	1880	1635	mA	
		I _{DD8W} (V _{DD}) x36	NA	NA	NA	NA	NA		
		I _{DD8W} (V _{EXT})	TBD	TBD	40	40	40		
Multibank write current: Dual bank write	BL = 4; Cyclic bank access using Dual Bank WRITE; Half of address bits change every two clock cycles; Continuous data; Measurement is taken during continuous WRITE	I _{DBWR} (V _{DD}) x18	TBD	TBD	2245	2245	2020	mA	
		I _{DBWR} (V _{DD}) x36	TBD	TBD	2170	2170	2035		
		I _{DBWR} (V _{EXT})	TBD	TBD	80	80	80		



Table 4: I_{DD} Operating Conditions and Maximum Limits (Continued)

Notes 1–6 apply to the entire table

Description	Condition	Symbol	-083F	-083E	-093F	-093E	-107E	Units	Notes
Multibank write current: Quad bank write	BL=4; Cyclic bank access using Quad Bank WRITE; Half of address bits change every two clock cycles; Continuous data; Measurement is taken during continuous WRITE; Subject to tSAW specification	I _{QBWR} (V _{DD}) x18	TBD	TBD	3000	3000	2880	mA	
		I _{QBWR} (V _{DD}) x36	TBD	TBD	3245	3245	2900		
		I _{QBWR} (V _{EXT})	TBD	TBD	120	120	125		
Operating burst read current example	BL = 2; Cyclic bank access; Half of address bits change every clock cycle; Continuous data; Measurement is taken during continuous READ	I _{DD2R} (V _{DD}) x18	TBD	TBD	2215	2215	2025	mA	
		I _{DD2R} (V _{DD}) x36	TBD	TBD	2255	2255	2050		
		I _{DD2R} (V _{EXT})	TBD	TBD	80	80	80		
Operating burst read current example	BL = 4; Cyclic bank access; Half of address bits change every two clock cycles; Continuous data; Measurement is taken during continuous READ	I _{DD4R} (V _{DD}) x18	TBD	TBD	2005	2005	1705	mA	
		I _{DD4R} (V _{DD}) x36	TBD	TBD	2020	2020	1720		
		I _{DD4R} (V _{EXT})	TBD	TBD	40	40	40		
Operating burst read current example	BL = 8; Cyclic bank access; Half of address bits change every four clock cycles; Continuous data; Measurement is taken during continuous READ	I _{DD8R} (V _{DD}) x18	TBD	TBD	1565	1565	1290	mA	
		I _{DD8R} (V _{DD}) x36	NA	NA	NA	NA	NA		
		I _{DD8R} (V _{EXT})	TBD	TBD	25	25	25		

- Notes:
- I_{DD} specifications are tested after the device is properly initialized. 0°C ≤ T_C ≤ +95°C; +1.28V ≤ V_{DD} ≤ +1.42V, +1.14V ≤ V_{DDQ} ≤ +1.26V, +2.38V ≤ V_{EXT} ≤ +2.63V, V_{REF} = V_{DDQ}/2.
 - I_{DD} measurements use t_{CK}(MIN), t_{RC}(MIN), and minimum data latency (RL and WL).
 - Input slew rate is 1V/ns for single ended signals and 2V/ns for differential signals.
 - Definitions for I_{DD} conditions:
 - LOW is defined as V_{IN} ≤ V_{IL(AC)MAX}.
 - HIGH is defined as V_{IN} ≥ V_{IH(AC)MIN}.
 - Continuous data is defined as half the DQ signals changing between HIGH and LOW every half clock cycle (twice per clock).
 - Continuous address is defined as half the address signals changing between HIGH and LOW every clock cycle (once per clock).
 - Sequential bank access is defined as the bank address incrementing by one every t_{RC}.
 - Cyclic bank access is defined as the bank address incrementing by one for each command access. For BL = 2 this is every clock, for BL = 4 this is every other clock, and for BL = 8 this is every fourth clock.
 - CS# is HIGH unless a READ, WRITE, AREF, or MRS command is registered. CS# never transitions more than once per clock cycle.
 - I_{DD} parameters are specified with ODT disabled.



Electrical Specifications – Absolute Ratings and I/O Capacitance

Absolute Maximum Ratings

Stresses greater than those listed may cause permanent damage to the device. This is a stress rating only, and functional operation of the device at these or any other conditions outside those indicated in the operational sections of this specification is not implied. Exposure to absolute maximum rating conditions for extended periods may adversely affect reliability.

Table 5: Absolute Maximum Ratings

Symbol	Parameter	Min	Max	Units
V _{DD}	V _{DD} supply voltage relative to V _{SS}	-0.4	1.975	V
V _{DDQ}	Voltage on V _{DDQ} supply relative to V _{SS}	-0.4	1.66	V
V _{IN} , V _{OUT}	Voltage on any ball relative to V _{SS}	-0.4	1.66	V
V _{EXT}	Voltage on V _{EXT} supply relative to V _{SS}	-0.4	2.8	V



Input/Output Capacitance

Table 6: Input/Output Capacitance

Notes 1 and 2 apply to entire table

Capacitance Parameters	Symbol	RL3-2400		RL3-2133		RL3-1866		Units	Notes
		Min	Max	Min	Max	Min	Max		
CK/CK#	C _{CK}	1.3	2.1	1.3	2.1	1.3	2.1	pF	
ΔC: CK to CK#	C _{DCK}	0	0.15	0	0.15	0	0.15	pF	
Single-ended I/O: DQ, DM	C _{IO}	1.9	2.9	1.9	3.0	1.9	3.1	pF	3
Input strobe: DK/DK#	C _{IO}	1.9	2.9	1.9	3.0	1.9	3.1	pF	
Output strobe: QK/QK#, QVLD	C _{IO}	1.9	2.9	1.9	3.0	1.9	3.1	pF	
ΔC: DK to DK#	C _{DDK}	0	0.15	0	0.15	0	0.15	pF	
ΔC: QK to QK#	C _{DQK}	0	0.15	0	0.15	0	0.15	pF	
ΔC: DQ to QK or DQ to DK	C _{DIO}	-0.5	0.3	-0.5	0.3	-0.5	0.3	pF	4
Inputs (CMD, ADDR)	C _I	1.25	2.25	1.25	2.25	1.25	2.25	pF	5
ΔC: CMD_ADDR to CK	C _{DI_CMD_ADDR}	-0.5	0.3	-0.5	0.3	-0.4	0.4	pF	6
JTAG balls	C _{JTAG}	1.5	4.5	1.5	4.5	1.5	4.5	pF	7
RESET#, MF balls	C _I	-	3.0	-	3.0	-	3.0	pF	

- Notes:
1. $+1.28V \leq V_{DD} \leq +1.42V$, $+1.14V \leq V_{DDQ} \leq 1.26V$, $+2.38V \leq V_{EXT} \leq +2.63V$, $V_{REF} = V_{SS}$, $f = 100$ MHz, $T_C = 25^\circ C$, $V_{OUT(DC)} = 0.5 \times V_{DDQ}$, V_{OUT} (peak-to-peak) = 0.1V.
 2. Capacitance is not tested on ZQ ball.
 3. DM input is grouped with the I/O balls, because they are matched in loading.
 4. $C_{DIO} = C_{IO(DQ)} - 0.5 \times (C_{IO} [QK] + C_{IO} [QK\#])$.
 5. Includes CS#, REF#, WE#, A[19:0], and BA[3:0].
 6. $C_{DI_CMD_ADDR} = C_I (CMD_ADDR) - 0.5 \times (C_{CK} [CK] + C_{CK} [CK\#])$.
 7. JTAG balls are tested at 50 MHz.



AC and DC Operating Conditions

Table 7: DC Electrical Characteristics and Operating Conditions

Note 1 applies to the entire table; Unless otherwise noted: $0^{\circ}\text{C} \leq T_C \leq +95^{\circ}\text{C}$; $+1.28\text{V} \leq V_{DD} \leq +1.42\text{V}$

Description	Symbol	Min	Max	Units	Notes
Supply voltage	V_{EXT}	2.38	2.63	V	
Supply voltage	V_{DD}	1.28	1.42	V	
Isolated output buffer supply (standard)	V_{DDQ}	1.14	1.26	V	
Isolated output buffer supply (optional for 2400 Mb/s support only)	V_{DDQ}	1.28	1.42	V	3
Reference voltage	V_{REF}	$0.49 \times V_{DDQ}$	$0.51 \times V_{DDQ}$	V	2, 4
Input HIGH (logic 1) voltage	$V_{IH(DC)}$	$V_{REF} + 0.10$	V_{DDQ}	V	
Input LOW (logic 0) voltage	$V_{IL(DC)}$	V_{SS}	$V_{REF} - 0.10$	V	
Input leakage current: Any input $0\text{V} \leq V_{IN} \leq V_{DD}$, V_{REF} ball $0\text{V} \leq V_{IN} \leq 1.1\text{V}$ (All other balls not under test = 0V)	I_{LI}	-2	2	μA	
Reference voltage current (All other balls not under test = 0V)	I_{REF}	-5	5	μA	

- Notes:
- All voltages referenced to V_{SS} (GND).
 - The nominal value of V_{REF} is expected to be $0.5 \times V_{DDQ}$ of the transmitting device. V_{REF} is expected to track variations in V_{DDQ} .
 - $1.35V V_{DDQ}$ can only be used to support 2400Mbps operation if required to close timing. It cannot be used to support any slower data rates. V_{DDQ} must be less than or equal to V_{DD} at all times.
 - Peak-to-peak noise (non-common mode) on V_{REF} may not exceed $\pm 2\%$ of the DC value. DC values are determined to be less than 20 MHz. Peak-to-peak AC noise on V_{REF} should not exceed $\pm 2\%$ of $V_{REF(DC)}$. Thus, from $V_{DDQ}/2$, V_{REF} is allowed $\pm 2\% V_{DDQ}/2$ for DC error and an additional $\pm 2\% V_{DDQ}/2$ for AC noise. The measurement is to be taken at the nearest V_{REF} bypass capacitor.

Table 8: Input AC Logic Levels

Notes 1-3 apply to entire table; Unless otherwise noted: $0^{\circ}\text{C} \leq T_C \leq +95^{\circ}\text{C}$; $+1.28\text{V} \leq V_{DD} \leq +1.42\text{V}$

Description	Symbol	Min	Max	Units
Input HIGH (logic 1) voltage	$V_{IH(AC150)}$	$V_{REF} + 0.15$	-	V
Input HIGH (logic 1) voltage	$V_{IH(AC135)}$	$V_{REF} + 0.135$	-	V
Input HIGH (logic 1) voltage	$V_{IH(AC120)}$	$V_{REF} + 0.12$	-	V
Input LOW (logic 0) voltage	$V_{IL(AC120)}$	-	$V_{REF} - 0.12$	V
Input LOW (logic 0) voltage	$V_{IL(AC135)}$	-	$V_{REF} - 0.135$	V
Input LOW (logic 0) voltage	$V_{IL(AC150)}$	-	$V_{REF} - 0.15$	V

- Notes:
- All voltages referenced to V_{SS} (GND).
 - The receiver will effectively switch as a result of the signal crossing the AC input level, and will remain in that state as long as the signal does not ring back above/below the DC input LOW/HIGH level.
 - Single-ended input slew rate = 1 V/ns ; maximum input voltage swing under test is 900mV (peak-to-peak).

Figure 5: Single-Ended Input Signal

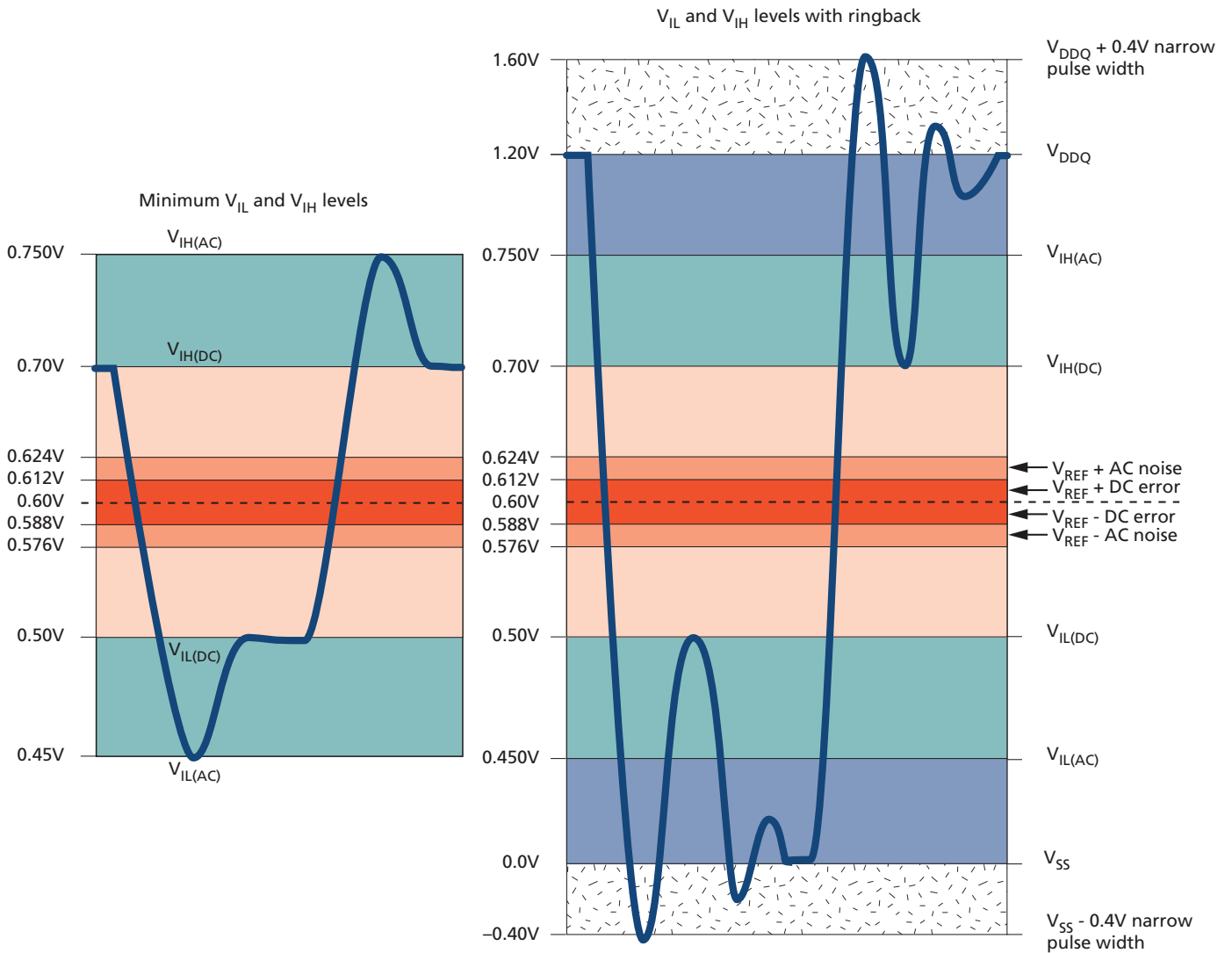

AC Overshoot/Undershoot Specifications

Table 9: Control and Address Balls

Parameter	RL3-2400	RL3-2133	RL3-1866
Maximum peak amplitude allowed for overshoot area	0.4V	0.4V	0.4V
Maximum peak amplitude allowed for undershoot area	0.4V	0.4V	0.4V
Maximum overshoot area above V_{DDQ}	0.22 Vns	0.25 Vns	0.28 Vns
Maximum undershoot area below V_{SS}/V_{SSQ}	0.22 Vns	0.25 Vns	0.28 Vns

Table 10: Clock, Data, Strobe, and Mask Balls

Parameter	RL3-2400	RL3-2133	RL3-1866
Maximum peak amplitude allowed for overshoot area	0.4V	0.4V	0.4V
Maximum peak amplitude allowed for undershoot area	0.4V	0.4V	0.4V
Maximum overshoot area above V_{DDQ}	0.09 Vns	0.10 Vns	0.11 Vns
Maximum undershoot area below V_{SS}/V_{SSQ}	0.09 Vns	0.10 Vns	0.11 Vns

Figure 6: Overshoot

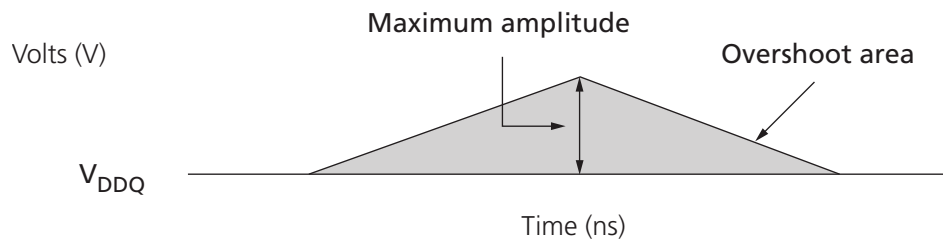

Figure 7: Undershoot

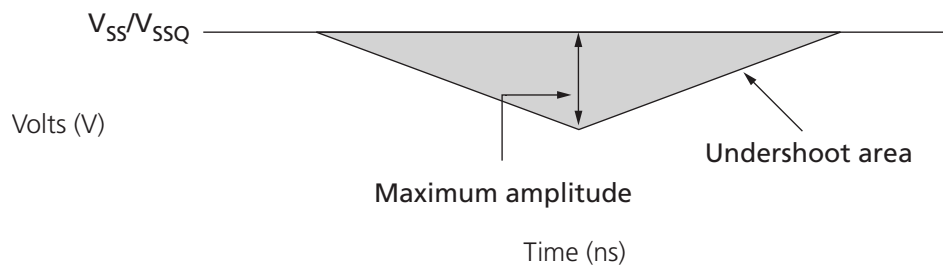

Table 11: Differential Input Operating Conditions (CK, CK# and DKx, DKx#)

Notes 1 and 2 apply to entire table

Parameter/Condition	Symbol	Min	Max	Units	Notes
Differential input voltage logic HIGH – slew	$V_{IH,diff_slew}$	+200	n/a	mV	3
Differential input voltage logic LOW – slew	$V_{IL,diff_slew}$	n/a	-200	mV	3
Differential input voltage logic HIGH	$V_{IH,diff(AC)}$	$2 \times (V_{IH(AC)} - V_{REF})$	V_{DDQ}	mV	4
Differential input voltage logic LOW	$V_{IL,diff(AC)}$	V_{SSQ}	$2 \times (V_{IL(AC)} - V_{REF})$	mV	5
Differential input crossing voltage relative to $V_{DD}/2$	V_{IX}	$V_{REF(DC)} - 150$	$V_{REF(DC)} + 150$	mV	6
Single-ended HIGH level	V_{SEH}	$V_{IH(AC)}$	V_{DDQ}	mV	4
Single-ended LOW level	V_{SEL}	V_{SSQ}	$V_{IL(AC)}$	mV	5

- Notes:
1. CK/CK# and DKx/DKx# are referenced to V_{DDQ} and V_{SSQ} .
 2. Differential input slew rate = 2 V/ns.
 3. Defines slew rate reference points, relative to input crossing voltages.
 4. Maximum limit is relative to single-ended signals; overshoot specifications are applicable.
 5. Minimum limit is relative to single-ended signals; undershoot specifications are applicable.
 6. The typical value of V_{IX} is expected to be about $0.5 \times V_{DDQ}$ of the transmitting device and V_{IX} is expected to track variations in V_{DDQ} . V_{IX} indicates the voltage at which differential input signals must cross.

Figure 8: V_{IX} for Differential Signals

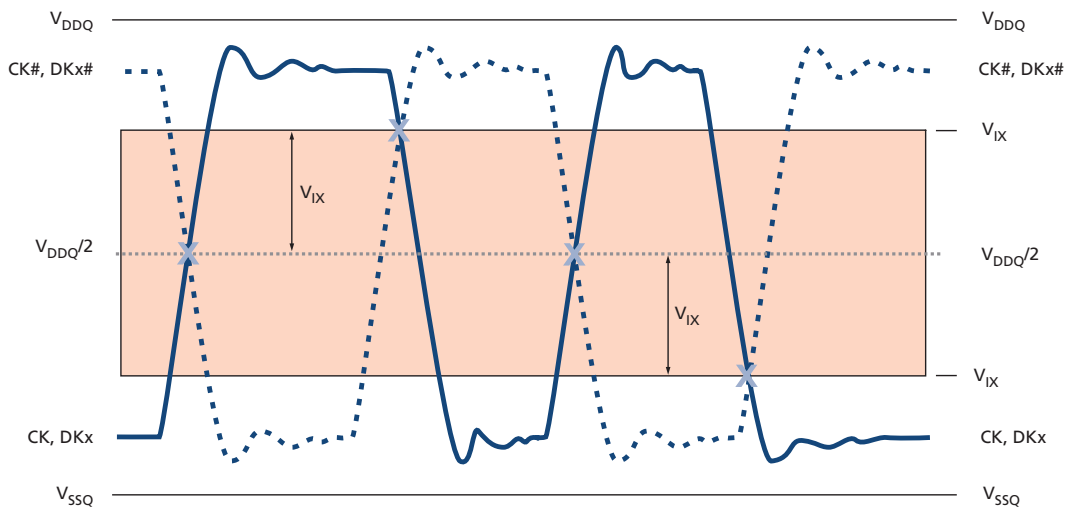

Figure 9: Single-Ended Requirements for Differential Signals

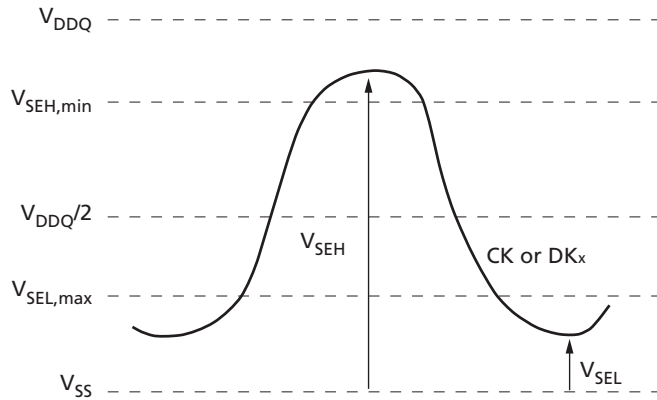

Figure 10: Definition of Differential AC Swing and t_{DVAC}

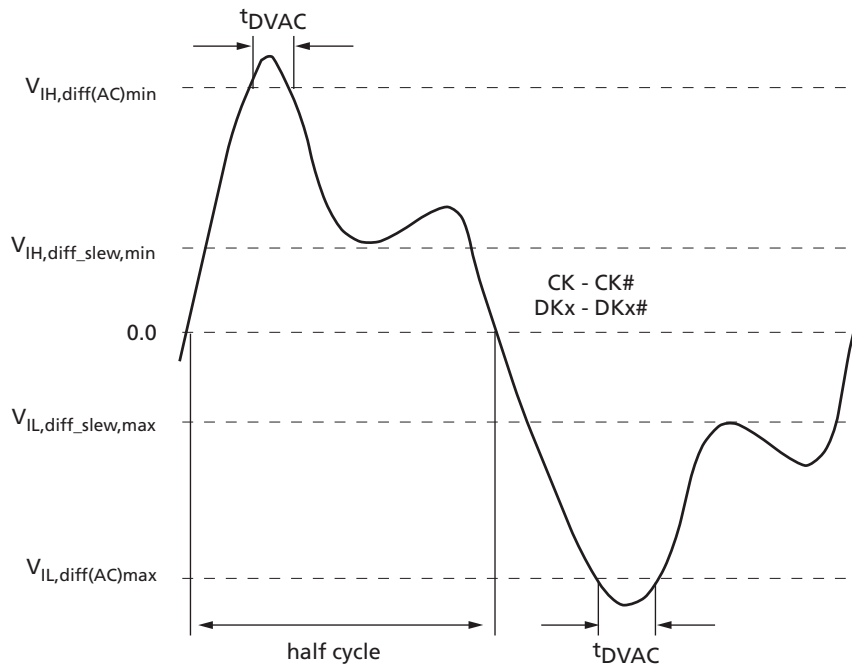



Table 12: Allowed Time Before Ringback (^tDVAC) for CK, CK#, DKx, and DKx#

Slew Rate (V/ns)	MIN ^t DVAC (ps) at V _{IH} /V _{IL,diff(AC)}
>4.0	175
4.0	170
3.0	167
2.0	163
1.9	162
1.6	161
1.4	159
1.2	155
1.0	150
<1.0	150

Slew Rate Definitions for Single-Ended Input Signals

Setup (^tIS and ^tDS) nominal slew rate for a rising signal is defined as the slew rate between the last crossing of V_{REF} and the first crossing of V_{IH(AC)min}. Setup (^tIS and ^tDS) nominal slew rate for a falling signal is defined as the slew rate between the last crossing of V_{REF} and the first crossing of V_{IL(AC)max}.

Hold (^tIH and ^tDH) nominal slew rate for a rising signal is defined as the slew rate between the last crossing of V_{IL(DC)max} and the first crossing of V_{REF}. Hold (^tIH and ^tDH) nominal slew rate for a falling signal is defined as the slew rate between the last crossing of V_{IH(DC)min} and the first crossing of V_{REF} (see Figure 12).

Table 13: Single-Ended Input Slew Rate Definition

Input Slew Rates (Linear Signals)		Measured		Calculation
Input	Edge	From	To	
Setup	Rising	V _{REF}	V _{IH(AC)min}	$[V_{IH(AC)min} - V_{REF}] / \Delta TRS$
	Falling	V _{REF}	V _{IL(AC)max}	$[V_{REF} - V_{IL(AC)max}] / \Delta TFS$
Hold	Rising	V _{IL(DC)max}	V _{REF}	$[V_{REF} - V_{IL(DC)max}] / \Delta TRH$
	Falling	V _{IH(DC)min}	V _{REF}	$[V_{IH(DC)min} - V_{REF}] / \Delta TFH$

Figure 11: Nominal Slew Rate Definition for Single-Ended Input Signals (Setup)

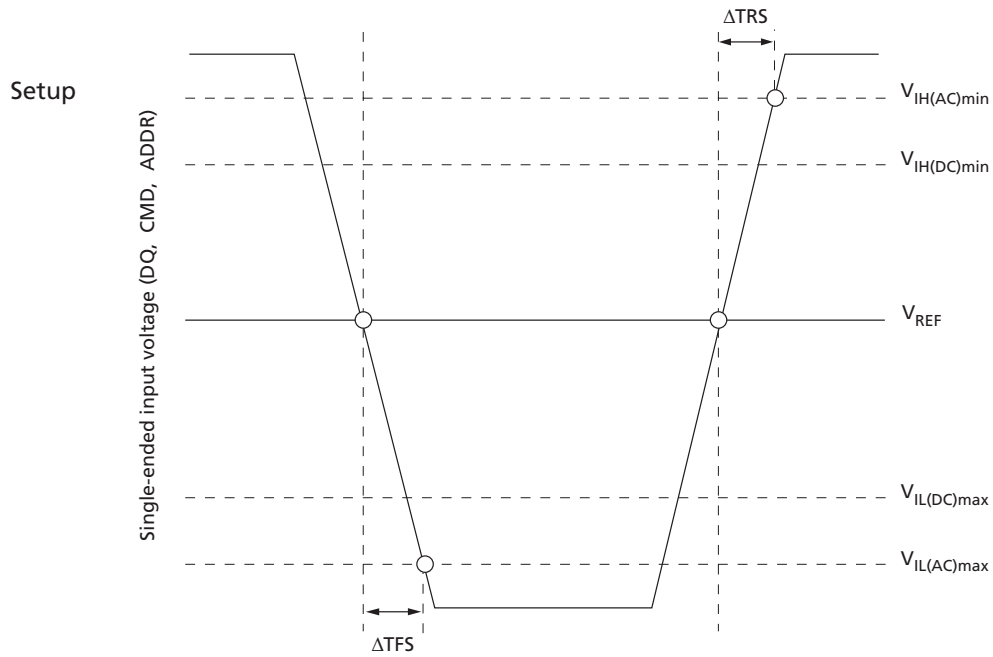
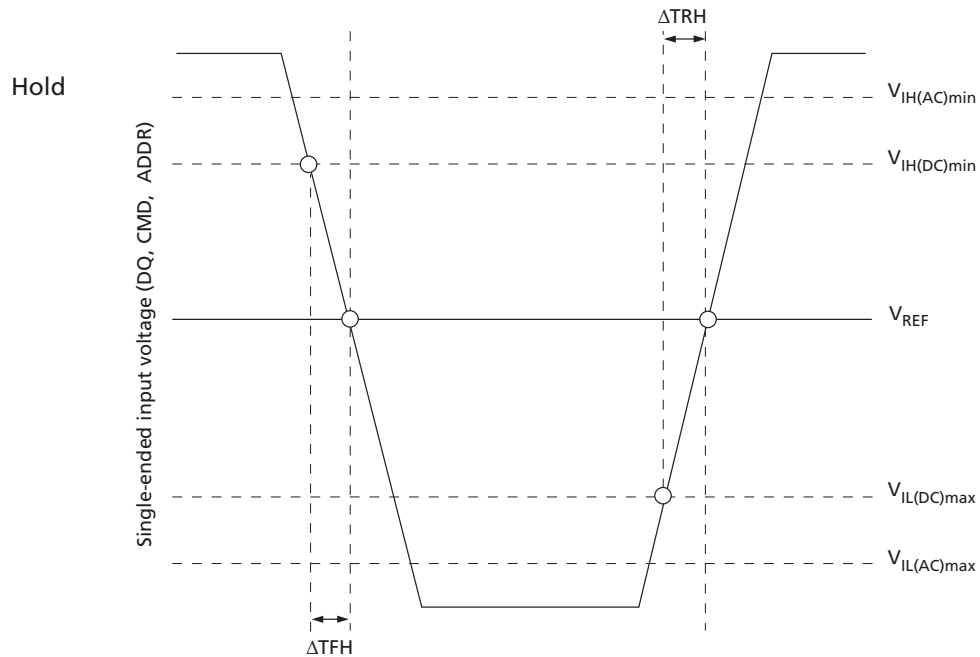

Figure 12: Nominal Slew Rate Definition for Single-Ended Input Signals (Hold)



Slew Rate Definitions for Differential Input Signals

Input slew rate for differential signals (CK, CK# and DKx, DKx#) are defined and measured as shown in the following two tables. The nominal slew rate for a rising signal is defined as the slew rate between $V_{IL,diff,max}$ and $V_{IH,diff,min}$. The nominal slew rate for a falling signal is defined as the slew rate between $V_{IH,diff,min}$ and $V_{IL,diff,max}$.

Table 14: Differential Input Slew Rate Definition

Differential Input Slew Rates (Linear Signals)		Measured		Calculation
Input	Edge	From	To	
CK and DK reference	Rising	$V_{IL,diff_slew,max}$	$V_{IH,diff_slew,min}$	$[V_{IH,diff_slew,min} - V_{IL,diff_slew,max}]/\Delta TR_{diff}$
	Falling	$V_{IH,diff_slew,min}$	$V_{IL,diff_slew,max}$	$[V_{IH,diff_slew,min} - V_{IL,diff_slew,max}]/\Delta TF_{diff}$

Figure 13: Nominal Differential Input Slew Rate Definition for CK, CK#, DKx, and DKx#

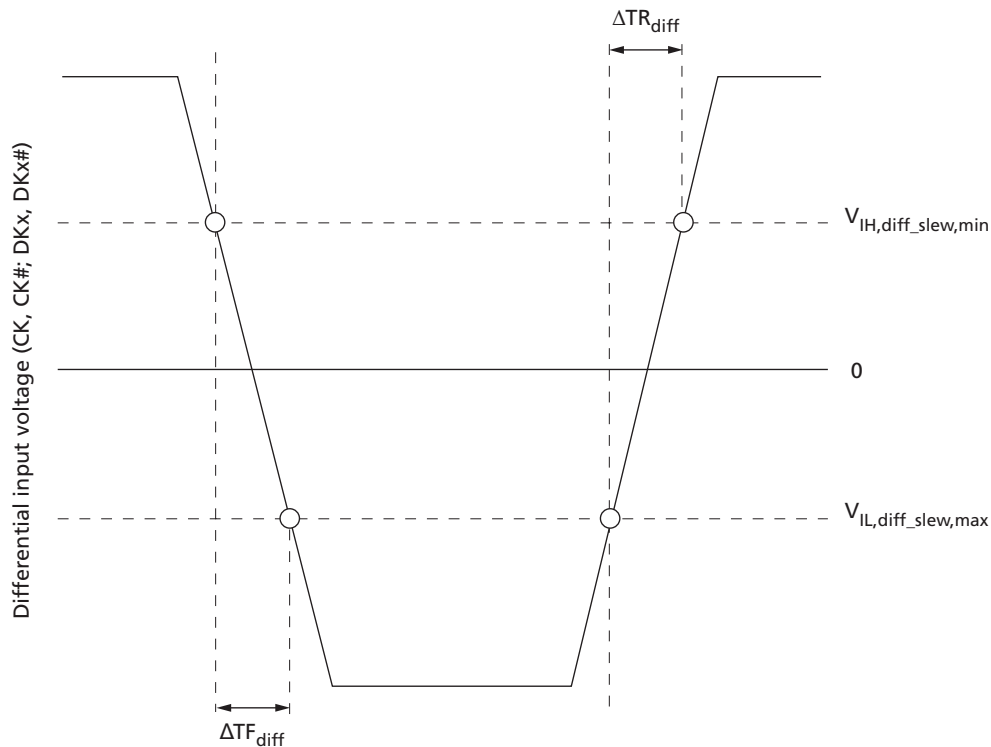

ODT Characteristics

ODT effective resistance, R_{TT} , is defined by MR1[4:2]. ODT is applied to the DQ, DM, and DKx, DKx# balls. The individual pull-up and pull-down resistors (R_{TTPU} and R_{TTPD}) are defined as follows:

$$R_{TTPU} = (V_{DDQ} - V_{OUT}) / |I_{OUT}|, \text{ under the condition that } R_{TTPD} \text{ is turned off}$$

$$R_{TTPD} = (V_{OUT}) / |I_{OUT}|, \text{ under the condition that } R_{TTPU} \text{ is turned off}$$

Figure 14: ODT Levels and I-V Characteristics

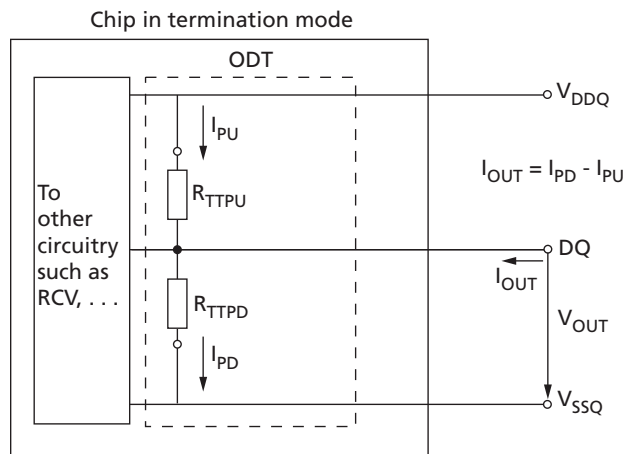

Table 15: ODT DC Electrical Characteristics

Parameter/Condition	Symbol	Min	Nom	Max	Units	Notes
R_{TT} effective impedance from $V_{IL(AC)}$ to $V_{IH(AC)}$	R_{TT_EFF}	See Table 16.				1, 2
Deviation of V_M with respect to $V_{DDQ}/2$	ΔV_m	-5	-	+5	%	3

- Notes:
1. Tolerance limits are applicable after proper ZQ calibration has been performed at a stable temperature and voltage. Refer to ODT Sensitivity if either the temperature or voltage changes after calibration.
 2. Measurement definition for R_{TT} : Apply $V_{IH(AC)}$ to ball under test and measure current $I[V_{IH(AC)}]$, then apply $V_{IL(AC)}$ to ball under test and measure current $I[V_{IL(AC)}]$:

$$R_{TT} = \frac{V_{IH(AC)} - V_{IL(AC)}}{|I[V_{IH(AC)}] - I[V_{IL(AC)}]|}$$

3. Measure voltage (V_M) at the tested ball with no load:

$$\Delta VM = \left(\frac{2 \times VM}{V_{DDQ}} - 1 \right) \times 100$$

ODT Resistors

The on-die termination resistance is selected by MR1[4:2]. The following table provides an overview of the ODT DC electrical characteristics. The values provided are not speci-



fication requirements; however, they can be used as design guidelines to indicate what R_{TT} is targeted to provide:

- R_{TT} 120Ω is made up of $R_{TT120(PD240)}$ and $R_{TT120(PU240)}$.
- R_{TT} 60Ω is made up of $R_{TT60(PD120)}$ and $R_{TT60(PU120)}$.
- R_{TT} 40Ω is made up of $R_{TT40(PD80)}$ and $R_{TT40(PU80)}$.

Table 16: R_{TT} Effective Impedances

R_{TT}	Resistor	V_{out}	Min	Nom	Max	Units
120Ω	$R_{TT120(PD240)}$	$0.2 \times V_{DDQ}$	0.6	1.0	1.1	RZQ/1
		$0.5 \times V_{DDQ}$	0.9	1.0	1.1	RZQ/1
		$0.8 \times V_{DDQ}$	0.9	1.0	1.4	RZQ/1
	$R_{TT120(PU240)}$	$0.2 \times V_{DDQ}$	0.9	1.0	1.4	RZQ/1
		$0.5 \times V_{DDQ}$	0.9	1.0	1.1	RZQ/1
		$0.8 \times V_{DDQ}$	0.6	1.0	1.1	RZQ/1
120Ω		$V_{IL(AC)}$ to $V_{IH(AC)}$	0.9	1.0	1.6	RZQ/2
60Ω	$R_{TT60(PD120)}$	$0.2 \times V_{DDQ}$	0.6	1.0	1.1	RZQ/2
		$0.5 \times V_{DDQ}$	0.9	1.0	1.1	RZQ/2
		$0.8 \times V_{DDQ}$	0.9	1.0	1.4	RZQ/2
	$R_{TT60(PU120)}$	$0.2 \times V_{DDQ}$	0.9	1.0	1.4	RZQ/2
		$0.5 \times V_{DDQ}$	0.9	1.0	1.1	RZQ/2
		$0.8 \times V_{DDQ}$	0.6	1.0	1.1	RZQ/2
60Ω		$V_{IL(AC)}$ to $V_{IH(AC)}$	0.9	1.0	1.6	RZQ/4
40Ω	$R_{TT40(PD80)}$	$0.2 \times V_{DDQ}$	0.6	1.0	1.1	RZQ/3
		$0.5 \times V_{DDQ}$	0.9	1.0	1.1	RZQ/3
		$0.8 \times V_{DDQ}$	0.9	1.0	1.4	RZQ/3
	$R_{TT40(PU80)}$	$0.2 \times V_{DDQ}$	0.9	1.0	1.4	RZQ/3
		$0.5 \times V_{DDQ}$	0.9	1.0	1.1	RZQ/3
		$0.8 \times V_{DDQ}$	0.6	1.0	1.1	RZQ/3
40Ω		$V_{IL(AC)}$ to $V_{IH(AC)}$	0.9	1.0	1.6	RZQ/6



ODT Sensitivity

If either temperature or voltage changes after I/O calibration, then the tolerance limits listed in Table 15 and Table 16 can be expected to widen according to Table 17 and Table 18.

Table 17: ODT Sensitivity Definition

Symbol	Min	Max	Units
R_{TT}	$0.9 - dR_{TTdT} \times DT - dR_{TTdV} \times DV $	$1.6 + dR_{TTdT} \times DT + dR_{TTdV} \times DV $	RZQ/(2,4,6)

Note: 1. $DT = T - T(@ \text{ calibration})$, $DV = V_{DDQ} - V_{DDQ}(@ \text{ calibration})$ or $V_{DD} - V_{DD}(@ \text{ calibration})$.

Table 18: ODT Temperature and Voltage Sensitivity

Change	Min	Max	Units
dR_{TTdT}	0	1.5	%/°C
dR_{TTdV}	0	0.15	%/mV

Output Driver Impedance

The output driver impedance is selected by MR1[1:0] during initialization. The selected value is able to maintain the tight tolerances specified if proper ZQ calibration is performed.

Output specifications refer to the default output driver unless specifically stated otherwise. A functional representation of the output buffer is shown below. The output driver impedance R_{ON} is defined by the value of the external reference resistor RZQ as follows:

- $R_{ON,x} = RZQ/y$ (with $RZQ = 240\Omega \pm 1\%$; $x = 40\Omega$ or 60Ω with $y = 6$ or 4 , respectively)

The individual pull-up and pull-down resistors ($R_{ON(PU)}$ and $R_{ON(PD)}$) are defined as follows:

- $R_{ON(PU)} = (V_{DDQ} - V_{OUT})/|I_{OUT}|$, when $R_{ON(PD)}$ is turned off
- $R_{ON(PD)} = (V_{OUT})/|I_{OUT}|$, when $R_{ON(PU)}$ is turned off

Figure 15: Output Driver

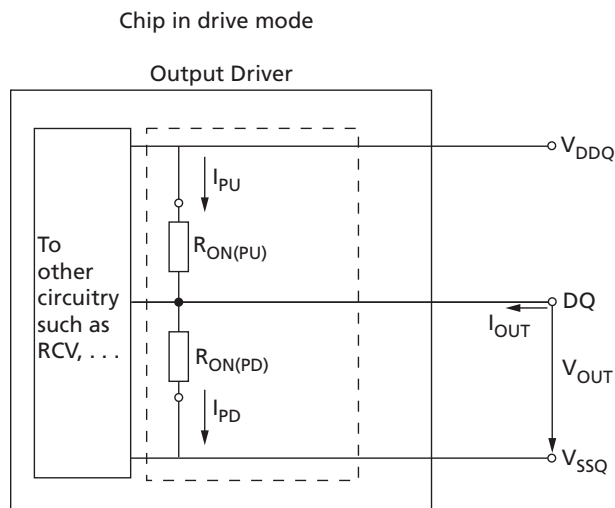



Table 19: Driver Pull-Up and Pull-Down Impedance Calculations

R_{ON}		Min	Nom	Max	Units
RZQ/6 = (240Ω ±1%)/6		39.6	40	40.4	Ω
RZQ/4 = (240Ω ±1%)/4		59.4	60	60.6	Ω
Driver	V_{OUT}	Min	Nom	Max	Units
40Ω pull-down	0.2 × V _{DDQ}	24	40	44	Ω
	0.5 × V _{DDQ}	36	40	44	Ω
	0.8 × V _{DDQ}	36	40	56	Ω
40Ω pull-up	0.2 × V _{DDQ}	36	40	56	Ω
	0.5 × V _{DDQ}	36	40	44	Ω
	0.8 × V _{DDQ}	24	40	44	Ω
60Ω pull-down	0.2 × V _{DDQ}	36	60	66	Ω
	0.5 × V _{DDQ}	54	60	66	Ω
	0.8 × V _{DDQ}	54	60	84	Ω
60Ω pull-up	0.2 × V _{DDQ}	54	60	84	Ω
	0.5 × V _{DDQ}	54	60	66	Ω
	0.8 × V _{DDQ}	36	60	66	Ω



Output Driver Sensitivity

If either the temperature or the voltage changes after ZQ calibration, then the tolerance limits listed in Table 19 can be expected to widen according to Table 20 and Table 21.

Table 20: Output Driver Sensitivity Definition

Symbol	Min	Max	Units
$R_{ON(PD)} @ 0.2 \times V_{DDQ}$	$0.6 - dR_{ONdTH} \times DT - dR_{ONdVH} \times DV$	$1.1 + dR_{ONdTH} \times DT + dR_{ONdVH} \times DV$	RZQ/(6, 4)
$R_{ON(PD)} @ 0.5 \times V_{DDQ}$	$0.9 - dR_{ONdTM} \times DT - dR_{ONdVM} \times DV$	$1.1 + dR_{ONdTM} \times DT + dR_{ONdVM} \times DV$	RZQ/(6, 4)
$R_{ON(PD)} @ 0.8 \times V_{DDQ}$	$0.9 - dR_{ONdTL} \times DT - dR_{ONdVL} \times DV$	$1.4 + dR_{ONdTL} \times DT + dR_{ONdVL} \times DV$	RZQ/(6, 4)
$R_{ON(PU)} @ 0.2 \times V_{DDQ}$	$0.9 - dR_{ONdTH} \times DT - dR_{ONdVH} \times DV$	$1.4 + dR_{ONdTH} \times DT + dR_{ONdVH} \times DV$	RZQ/(6, 4)
$R_{ON(PU)} @ 0.5 \times V_{DDQ}$	$0.9 - dR_{ONdTM} \times DT - dR_{ONdVM} \times DV$	$1.1 + dR_{ONdTM} \times DT + dR_{ONdVM} \times DV$	RZQ/(6, 4)
$R_{ON(PU)} @ 0.8 \times V_{DDQ}$	$0.6 - dR_{ONdTL} \times DT - dR_{ONdVL} \times DV$	$1.1 + dR_{ONdTL} \times DT + dR_{ONdVL} \times DV$	RZQ/(6, 4)

Note: 1. $DT = T - T(@ \text{ calibration})$, $DV = V_{DDQ} - V_{DDQ}(@ \text{ calibration})$ or $V_{DD} - V_{DD}(@ \text{ calibration})$.

Table 21: Output Driver Voltage and Temperature Sensitivity

Change	Min	Max	Unit
dR_{ONdTM}	0	1.5	%/°C
dR_{ONdVM}	0	0.15	%/mV
dR_{ONdTL}	0	1.5	%/°C
dR_{ONdVL}	0	0.15	%/mV
dR_{ONdTH}	0	1.5	%/°C
dR_{ONdVH}	0	0.15	%/mV



Output Characteristics and Operating Conditions

Table 22: Single-Ended Output Driver Characteristics

Note 1 and 2 apply to entire table

Parameter/Condition	Symbol	Min	Max	Units	Notes
Output leakage current; DQ are disabled; Any output ball $0V \leq V_{OUT} \leq V_{DDQ}$; ODT is disabled; All other balls not under test = 0V	I_{OZ}	-5	5	μA	
Output slew rate: Single-ended; For rising and falling edges, measures between $V_{OL(AC)} = V_{REF} - 0.1 \times V_{DDQ}$ and $V_{OH(AC)} = V_{REF} + 0.1 \times V_{DDQ}$	SR_{QSE}	2.5	6	V/ns	4, 5
Single-ended DC high-level output voltage	$V_{OH(DC)}$	$0.8 \times V_{DDQ}$		V	6
Single-ended DC mid-point level output voltage	$V_{OM(DC)}$	$0.5 \times V_{DDQ}$		V	6
Single-ended DC low-level output voltage	$V_{OL(DC)}$	$0.2 \times V_{DDQ}$		V	6
Single-ended AC high-level output voltage	$V_{OH(AC)}$	$V_{TT} + 0.1 \times V_{DDQ}$		V	7, 8, 9
Single-ended AC low-level output voltage	$V_{OL(AC)}$	$V_{TT} - 0.1 \times V_{DDQ}$		V	7, 8, 9
Impedance delta between pull-up and pull-down for DQ and QVLD	MM_{PUPD}	-10	10	%	3
Test load for AC timing and output slew rates	Output to $V_{TT} (V_{DDQ}/2)$ via 25 Ω resistor				9

- Notes:
- All voltages are referenced to V_{SS} .
 - RZQ is 240 Ω ($\pm 1\%$) and is applicable after proper ZQ calibration has been performed at a stable temperature and voltage.
 - Measurement definition for mismatch between pull-up and pull-down (MM_{PUPD}). Measure both $R_{ON(PU)}$ and $R_{ON(PD)}$ at $0.5 \times V_{DDQ}$:

$$MM_{PUPD} = \frac{R_{onPU} - R_{onPD}}{R_{onNOM}} \times 100$$

- The 6 V/ns maximum is applicable for a single DQ signal when it is switching either from HIGH to LOW or LOW to HIGH while the remaining DQ signals in the same byte lane are either all static or switching the opposite direction. For all other DQ signal switching combinations, the maximum limit of 6 V/ns is reduced to 5 V/ns.
- See Table 24 for output slew rate.
- See the Driver Pull-Up and Pull-Down Impedance Calculations table for IV curve linearity. Do not use AC test load.
- $V_{TT} = V_{DDQ}/2$
- See Figure 16 for an example of a single-ended output signal.
- See Figure 18 for the test load configuration.



Table 23: Differential Output Driver Characteristics

Notes 1 and 2 apply to entire table

Parameter/Condition	Symbol	Min	Max	Units	Notes
Output leakage current; DQ are disabled; Any output ball $0V \leq V_{OUT} \leq V_{DDQ}$; ODT is disabled; All other balls not under test = 0V	I_{OZ}	-5	5	μA	
Output slew rate: Differential; For rising and falling edges, measures between $V_{OL,diff(AC)} = -0.2 \times V_{DDQ}$ and $V_{OH,diff(AC)} = +0.2 \times V_{DDQ}$	SRQ_{diff}	5	12	V/ns	5
Output differential cross-point voltage	$V_{OX(AC)}$	$V_{REF} - 150$	$V_{REF} + 150$	mV	6
Differential high-level output voltage	$V_{OH,diff(AC)}$	$+0.2 \times V_{DDQ}$		V	6
Differential low-level output voltage	$V_{OL,diff(AC)}$	$-0.2 \times V_{DDQ}$		V	6
Delta resistance between pull-up and pull-down for QK/QK#	MM_{PUPD}	-10	10	%	3
Test load for AC timing and output slew rates	Output to V_{TT} ($V_{DDQ}/2$) via 25 Ω resistor				4

- Notes:
1. All voltages are referenced to V_{SS} .
 2. RZQ is 240 Ω ($\pm 1\%$) and is applicable after proper ZQ calibration has been performed at a stable temperature and voltage.
 3. Measurement definition for mismatch between pull-up and pull-down (MM_{PUPD}). Measure both $R_{ON(PU)}$ and $R_{ON(PD)}$ at $0.5 \times V_{DDQ}$:

$$MM_{PUPD} = \frac{R_{onPU} - R_{onPD}}{R_{onNOM}} \times 100$$

4. See Figure 18 for the test load configuration.
5. See Table 25 for the output slew rate.
6. See Figure 17 for an example of a differential output signal.

Figure 16: DQ Output Signal

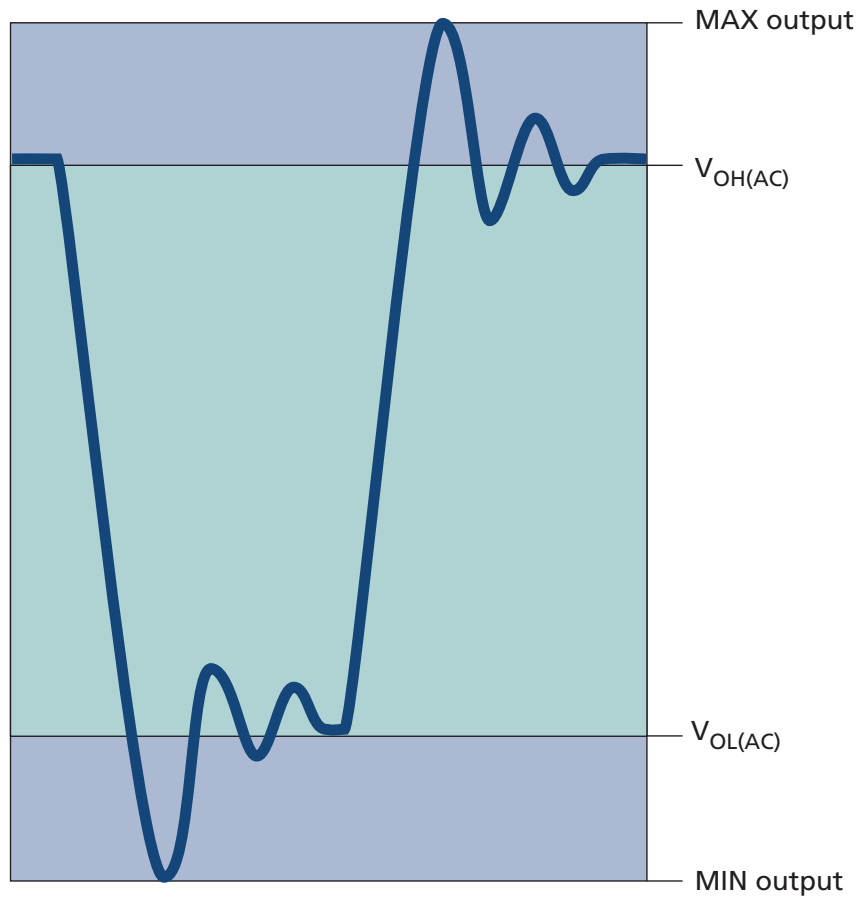
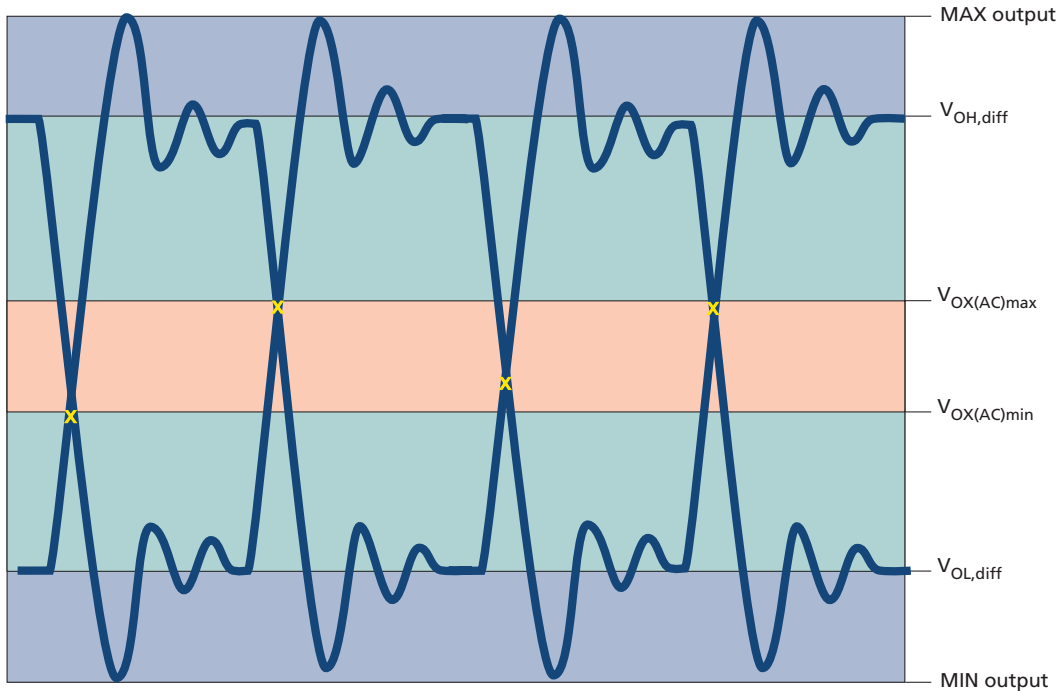

Figure 17: Differential Output Signal



Reference Output Load

The following figure represents the effective reference load of 25Ω used in defining the relevant device AC timing parameters as well as the output slew rate measurements. It is not intended to be a precise representation of a particular system environment or a depiction of the actual load presented by a production tester. System designers should use IBIS or other simulation tools to correlate the timing reference load to a system environment.

Figure 18: Reference Output Load for AC Timing and Output Slew Rate

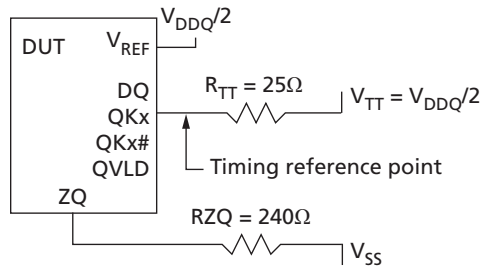

Slew Rate Definitions for Single-Ended Output Signals

The single-ended output driver is summarized in the following table. With the reference load for timing measurements, the output slew rate for falling and rising edges is defined and measured between $V_{OL(AC)}$ and $V_{OH(AC)}$ for single-ended signals.

Table 24: Single-Ended Output Slew Rate Definition

Single-Ended Output Slew Rates (Linear Signals)		Measured		Calculation
Output	Edge	From	To	
DQ and QVLD	Rising	$V_{OL(AC)}$	$V_{OH(AC)}$	$\frac{V_{OH(AC)} - V_{OL(AC)}}{\Delta TR_{SE}}$
	Falling	$V_{OH(AC)}$	$V_{OL(AC)}$	$\frac{V_{OH(AC)} - V_{OL(AC)}}{\Delta TF_{SE}}$

Figure 19: Nominal Slew Rate Definition for Single-Ended Output Signals

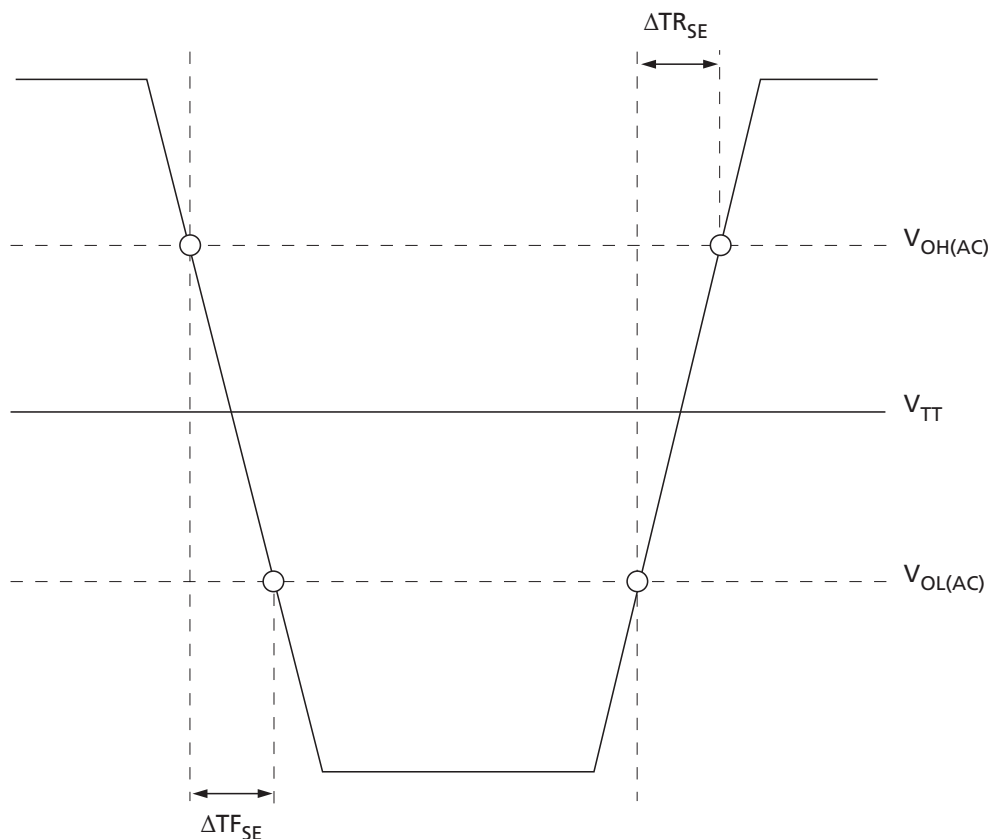



Slew Rate Definitions for Differential Output Signals

The differential output driver is summarized in the following table. With the reference load for timing measurements, the output slew rate for falling and rising edges is defined and measured between $V_{OL(AC)}$ and $V_{OH(AC)}$ for differential signals.

Table 25: Differential Output Slew Rate Definition

Differential Output Slew Rates (Linear Signals)		Measured		Calculation
Output	Edge	From	To	
QKx, QKx#	Rising	$V_{OL,diff(AC)}$	$V_{OH,diff(AC)}$	$\frac{V_{OH,diff(AC)max} - V_{OL,diff(AC)}}{\Delta TR_{diff}}$
	Falling	$V_{OH,diff(AC)}$	$V_{OL,diff(AC)}$	$\frac{V_{OH,diff(AC)} - V_{OL,diff(AC)}}{\Delta TF_{diff}}$

Figure 20: Nominal Differential Output Slew Rate Definition for QKx, QKx#

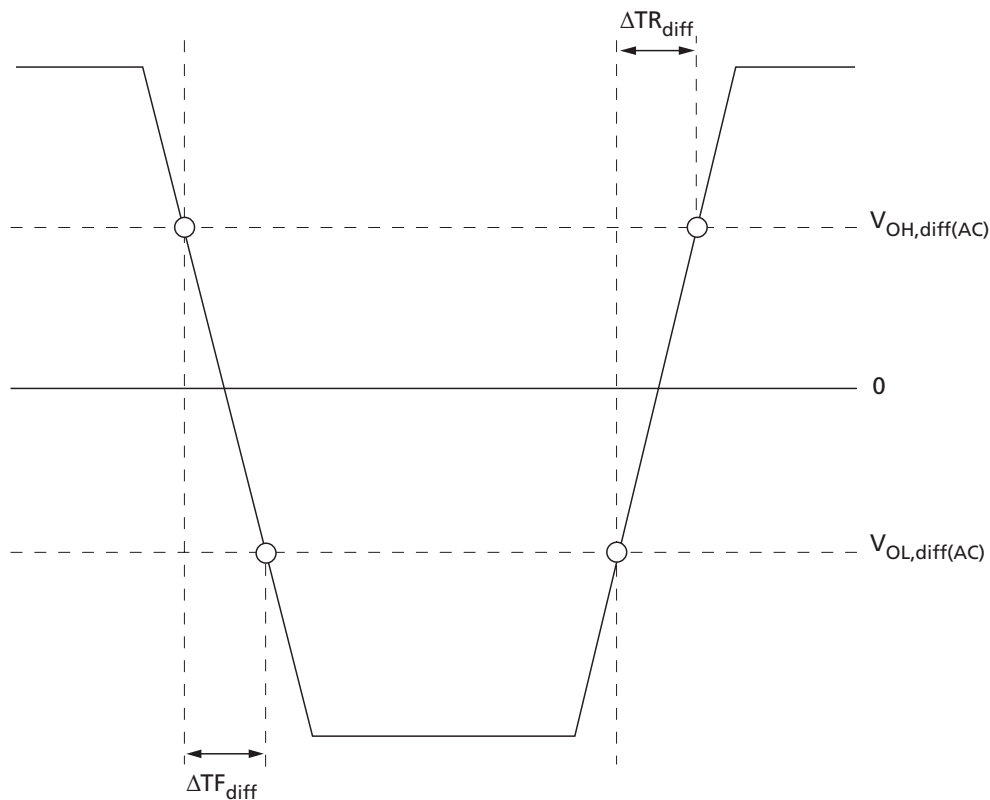



Speed Bin Tables

Table 26: RL3 2400/2133/1866 Speed Bins

Parameter	Symbol	-083F		-083E		-093F		-093E		-107E		Units
		Min	Max	Min	Max	Min	Max	Min	Max	Min	Max	
Clock Timing												
RL = 5 ; WL = 6	t _{CK (avg)}	3	4.3	3	4.3	3	4.3	3	4.3	3.5	4.3	ns
RL = 6 ; WL = 7	t _{CK (avg)}	2.5	3.5	2.5	4	2.5	3.5	2.5	3.5	3	3.5	ns
RL = 7 ; WL = 8	t _{CK (avg)}	2.5	3	2.5	3	2.5	3	2.5	3	2.5	3	ns
RL = 8 ; WL = 9	t _{CK (avg)}	1.875	2.5	1.875	3	1.875	2.5	1.875	2.5	2	2.5	ns
RL = 9 ; WL = 10	t _{CK (avg)}	1.875	2	1.875	2	1.875	2	1.875	2	1.875	2	ns
RL = 10 ; WL = 11	t _{CK (avg)}	1.5	2	1.5	2	1.5	2	1.5	2	1.875	2	ns
RL = 11 ; WL = 12	t _{CK (avg)}	1.5	1.875	1.5	2	1.5	1.875	1.5	1.875	1.5	1.875	ns
RL = 12 ; WL = 13	t _{CK (avg)}	1.25	1.875	1.25	1.875	1.25	1.875	1.25	1.5	1.5	1.66	ns
RL = 13 ; WL = 14	t _{CK (avg)}	1.25	1.5	1.25	1.5	1.25	1.5	1.25	1.5	1.25	1.5	ns
RL = 14 ; WL = 15	t _{CK (avg)}	1.07	1.5	1.07	1.5	1.07	1.5	1.07	1.25	1.25	1.33	ns
RL = 15 ; WL = 16	t _{CK (avg)}	1.0	1.25	1.0	1.25	1.0	1.25	1.0	1.25	1.07	1.33	ns
RL = 16 ; WL = 17	t _{CK (avg)}	0.9375	1.25	0.9375	1.25	0.9375	1.25	0.9375	1.25	Reserved		ns
RL = 17 ; WL = 18	t _{CK (avg)}	0.9375	1.07	0.9375	1.07	0.9375	1.07	0.9375	1.07	Reserved		ns
RL = 18 ; WL = 19	t _{CK (avg)}	0.8333	1.07	0.8333	1.07	Reserved		Reserved		Reserved		ns
Row Cycle Timing												
Row cycle time	t _{RC}	6.67	–	7.5	–	7.5	–	8	–	8	–	ns



AC Electrical Characteristics

Table 27: AC Electrical Characteristics

Notes 1–7 apply to entire table

Parameter		Symbol	RL3-2400		RL3-2133		RL3-1866		Units	Notes
			Min	Max	Min	Max	Min	Max		
Clock Timing										
Clock period average: DLL disable mode		$t_{CK}(DLL_DIS)$	8	488	8	488	8	488	ns	8
Clock period average: DLL enable mode		$t_{CK}(avg)$	See t_{CK} values in the RL3 Speed Bins table.						ns	9, 10
High pulse width average		$t_{CH}(avg)$	0.47	0.53	0.47	0.53	0.47	0.53	CK	11
Low pulse width average		$t_{CL}(avg)$	0.47	0.53	0.47	0.53	0.47	0.53	CK	11
Clock period jitter	DLL locked	$t_{JIT}(per)$	-42	42	-50	50	-60	60	ps	12
	DLL locking	$t_{JIT}(per),lck$	-34	34	-40	40	-50	50	ps	12
Clock absolute period		$t_{CK}(abs)$	MIN = $t_{CK}(avg),min + t_{JIT}(per),min$; MAX = $t_{CK}(avg),max + t_{JIT}(per),max$						ps	
Clock absolute high pulse width		$t_{CH}(abs)$	0.43	-	0.43	-	0.43	-	$t_{CK}(avg)$	13
Clock absolute low pulse width		$t_{CL}(abs)$	0.43	-	0.43	-	0.43	-	$t_{CK}(avg)$	14
Cycle-to-cycle jitter	DLL locked	$t_{JIT}(cc)$	83		100		120		ps	15
	DLL locking	$t_{JIT}(cc),lck$	67		80		100		ps	15
Cumulative error across	2 cycles	$t_{ERR}(2per)$	-62	62	-74	74	-88	88	ps	16
	3 cycles	$t_{ERR}(3per)$	-73	73	-87	87	-105	105	ps	16
	4 cycles	$t_{ERR}(4per)$	-81	81	-97	97	-117	117	ps	16
	5 cycles	$t_{ERR}(5per)$	-87	87	-105	105	-126	126	ps	16
	6 cycles	$t_{ERR}(6per)$	-92	92	-111	111	-133	133	ps	16
	7 cycles	$t_{ERR}(7per)$	-97	97	-116	116	-139	139	ps	16
	8 cycles	$t_{ERR}(8per)$	-101	101	-121	121	-145	145	ps	16
	9 cycles	$t_{ERR}(9per)$	-104	104	-125	125	-150	150	ps	16
	10 cycles	$t_{ERR}(10per)$	-107	107	-128	128	-154	154	ps	16
	11 cycles	$t_{ERR}(11per)$	-110	110	-132	132	-158	158	ps	16
	12 cycles	$t_{ERR}(12per)$	-112	112	-134	134	-161	161	ps	16
	n = 13, 14 ... 49, 50 cycles	$t_{ERR}(nper)$	$t_{ERR}(nper),min = [1 + 0.68LN(n)] \times t_{JIT}(per),min$ $t_{ERR}(nper),max = [1 + 0.68LN(n)] \times t_{JIT}(per),max$						ps	16
DQ Input Timing										
Data setup time to DK, DK#	Base (specification)	$t_{DS}(AC150)$	-35	-	-30	-	-15	-	ps	17, 18
	V_{REF} @ 1 V/ns		115	-	120	-	135	-	ps	18, 19



Table 27: AC Electrical Characteristics (Continued)

Notes 1–7 apply to entire table

Parameter		Symbol	RL3-2400		RL3-2133		RL3-1866		Units	Notes
			Min	Max	Min	Max	Min	Max		
Data setup time to DK, DK#	Base (specification)	$t_{DS}(AC135)$	48	–	53	–	68	–	ps	17, 18
	V_{REF} @ 2 V/ns		115	–	120	–	135	–	ps	18, 19
Data setup time to DK, DK#	Base (specification)	$t_{DS}(AC120)$	55	–	60	–	75	–	ps	17, 18
	V_{REF} @ 2 V/ns		115	–	120	–	135	–	ps	18, 19
Data hold time from DK, DK#	Base (specification)	$t_{DH}(DC100)$	0	–	5	–	20	–	ps	17, 18
	V_{REF} @ 1 V/ns		100	–	105	–	120	–	ps	
Data hold time from DK, DK#	Base (specification)	$t_{DH}(DC100)$	50	–	55	–	70	–	ps	17, 18
	V_{REF} @ 2 V/ns		100	–	105	–	120	–	ps	
Minimum data pulse width		t_{DIPW}	240	–	280	–	320	–	ps	20
DQ Output Timing										
QK, QK# edge to output data edge within byte group		t_{QKQ_x}	–	65	–	75	–	85	ps	
QK, QK# edge to any output data edge within specific data word grouping (only for x36)		t_{QKQ02} , t_{QKQ13}	–	100	–	125	–	135	ps	22
DQ output hold time from QK, QK#		t_{QH}	0.38	–	0.38	–	0.38	–	$t_{CK}(avg)$	23
DQ Low-Z time from CK, CK#		t_{LZ}	–340	170	–360	180	–390	195	ps	24, 26
DQ High-Z time from CK, CK#		t_{HZ}	–	170	–	180	–	195	ps	24, 26
Input and Output Strobe Timing										
DK (rising), DK# (falling) edge to/from CK (rising), CK# (falling) edge		t_{CKDK}	–0.27	0.27	–0.27	0.27	–0.27	0.27	CK	29
DK, DK# differential input HIGH width		t_{DKH}	0.45	0.55	0.45	0.55	0.45	0.55	CK	
DK, DK# differential input LOW width		t_{DKL}	0.45	0.55	0.45	0.55	0.45	0.55	CK	
QK (rising), QK# (falling) edge to CK (rising), CK# (falling) edge		t_{CKQK}	–130 – 5% t_{CK}	130 + 5% t_{CK}	–135 – 5% t_{CK}	135 + 5% t_{CK}	–140 – 5% t_{CK}	140 + 5% t_{CK}	ps	26
QK (rising), QK# (falling) edge to CK (rising), CK# (falling) edge with DLL disabled		$t_{CKQK DLL_DIS}$	1	10	1	10	1	10	ns	27



Table 27: AC Electrical Characteristics (Continued)

Notes 1–7 apply to entire table

Parameter	Symbol	RL3-2400		RL3-2133		RL3-1866		Units	Notes	
		Min	Max	Min	Max	Min	Max			
QK, QK# differential output HIGH time	t_{QKH}	0.4	–	0.4	–	0.4	–	CK	23	
QK, QK# differential output LOW time	t_{QKL}	0.4	–	0.4	–	0.4	–	CK	23	
QK (falling), QK# (rising) edge to QVLD edge	t_{QKVLD}	–	115	–	125	–	135	ps	25	
Command and Address Timing										
CTRL, CMD, ADDR, set-up to CK, CK#	Base (specification)	$t_{IS}(AC150)$	70	–	85	–	120	–	ps	28, 30
	V_{REF} @ 1 V/ns		220	–	235	–	270	–	ps	19, 30
CTRL, CMD, ADDR, set-up to CK, CK#	Base (specification)	$t_{IS}(AC135)$	85	–	100	–	135	–	ps	28, 30
	V_{REF} @ 1 V/ns		220	–	235	–	270	–	ps	19, 30
CTRL, CMD, ADDR, set-up to CK, CK#	Base (specification)	$t_{IS}(AC120)$	100	–	115	–	150	–	ps	28, 30
	V_{REF} @ 1 V/ns		220	–	235	–	270	–	ps	19, 30
CTRL, CMD, ADDR, hold from CK, CK#	Base (specification)	$t_{IH}(DC100)$	50	–	65	–	100	–	ps	28, 30
	V_{REF} @ 1 V/ns		150	–	165	–	200	–	ps	19, 30
Minimum CTRL, CMD, ADDR pulse width	t_{IPW}	410	–	470	–	535	–	ps	20	
Row cycle time	t_{RC}	See minimum t_{RC} values in the RL3 Speed Bins table.						ns	21, 34	
Refresh rate	t_{REF}	64	–	64	–	64	–	ms		
Sixteen-bank access window	t_{SAW}	8	–	8	–	8	–	ns		
Multibank access delay	t_{MMD}	2	–	2	–	2	–	CK	33	
WRITE-to-READ to same address	t_{WTR}	WL + BL/2	–	WL + BL/2	–	WL + BL/2	–	CK	32	
Mode register set cycle time to any command	t_{MRSC}	12	–	12	–	12	–	CK		
READ training register minimum READ time	t_{RTRS}	2	–	2	–	2	–	CK		
READ training register burst end to mode register set for training register exit	t_{RTRE}	2	–	1	–	1	–	CK		
Calibration Timing										



Table 27: AC Electrical Characteristics (Continued)

Notes 1–7 apply to entire table

Parameter		Symbol	RL3-2400		RL3-2133		RL3-1866		Units	Notes
			Min	Max	Min	Max	Min	Max		
ZQCL: Long calibration time	POWER-UP and RESET operation	t_{ZQinit}	1024	–	1024	–	1024	–	CK	
	Normal operation	t_{ZQoper}	512	–	512	–	512	–	CK	
ZQCS: Short calibration time		t_{ZQcs}	128	–	128	–	128	–	CK	
Initialization and Reset Timing										
Begin power-supply ramp to power supplies stable		$t_{V_{DDPR}}$	–	200	–	200	–	200	ms	
RESET# LOW to power supplies stable		t_{RPS}	–	200	–	200	–	200	ms	
RESET# LOW to I/O and R_{TT} High-Z		t_{IOz}	–	20	–	20	–	20	ns	31

- Notes:
- Parameters are applicable with $0^{\circ}\text{C} \leq T_C \leq +95^{\circ}\text{C}$; $+1.28\text{V} \leq V_{DD} \leq +1.42\text{V}$, $+2.38\text{V} \leq V_{EXT} \leq +2.63\text{V}$, $+1.14\text{V} \leq V_{DDQ} \leq 1.26\text{V}$.
 - All voltages are referenced to V_{SS} .
 - The unit $t_{CK(avg)}$ represents the actual $t_{CK(avg)}$ of the input clock under operation. The unit CK represents one clock cycle of the input clock, counting the actual clock edges.
 - AC timing and I_{DD} tests may use a V_{IL} -to- V_{IH} swing of up to 900mV in the test environment, but input timing is still referenced to V_{REF} (except t_{IS} , t_{IH} , t_{DS} , and t_{DH} use the AC/DC trip points and CK, CK# and DKx, DKx# use their crossing points). The minimum slew rate for the input signals used to test the device is 1 V/ns for single-ended inputs and 2 V/ns for differential inputs in the range between $V_{IL(AC)}$ and $V_{IH(AC)}$.
 - All timings that use time-based values (ns, μs , ms) should use $t_{CK(avg)}$ to determine the correct number of clocks. In the case of noninteger results, all minimum limits should be rounded up to the nearest whole integer, and all maximum limits should be rounded down to the nearest whole integer.
 - The term “strobe” refers to the DK and DK# or QK and QK# differential crossing point when DK and QK, respectively, is the rising edge. Clock, or CK, refers to the CK and CK# differential crossing point when CK is the rising edge.
 - The output load defined in Figure 18 is used for all AC timing and slew rates. The actual test load may be different. The output signal voltage reference point is $V_{DDQ}/2$ for single-ended signals and the crossing point for differential signals.
 - When operating in DLL disable mode, Micron does not warrant compliance with normal mode timings or functionality.
 - The clock’s $t_{CK(avg)}$ is the average clock over any 200 consecutive clocks and $t_{CK(avg),min}$ is the smallest clock rate allowed, with the exception of a deviation due to clock jitter. Input clock jitter is allowed provided it does not exceed values specified and must be of a random Gaussian distribution in nature.
 - Spread spectrum is not included in the jitter specification values. However, the input clock can accommodate spread spectrum at a sweep rate in the range of 20–60 kHz with an additional 1% of $t_{CK(avg)}$ as a long-term jitter component; however, the spread spectrum may not use a clock rate below $t_{CK(avg),min}$.
 - The clock’s $t_{CH(avg)}$ and $t_{CL(avg)}$ are the average half-clock period over any 200 consecutive clocks and is the smallest clock half-period allowed, with the exception of a deviation due to clock jitter. Input clock jitter is allowed provided it does not exceed values specified and must be of a random Gaussian distribution in nature.



12. The period jitter, $t_{JIT(per)}$, is the maximum deviation in the clock period from the average or nominal clock. It is allowed in either the positive or negative direction.
13. $t_{CH(abs)}$ is the absolute instantaneous clock high pulse width as measured from one rising edge to the following falling edge.
14. $t_{CL(abs)}$ is the absolute instantaneous clock low pulse width as measured from one falling edge to the following rising edge.
15. The cycle-to-cycle jitter, $t_{JIT(cc)}$, is the amount the clock period can deviate from one cycle to the next. It is important to keep cycle-to-cycle jitter at a minimum during the DLL locking time.
16. The cumulative jitter error, $t_{ERR(nper)}$, where n is the number of clocks between 2 and 50, is the amount of clock time allowed to accumulate consecutively away from the average clock over n number of clock cycles.
17. $t_{DS(base)}$ and $t_{DH(base)}$ values are for a single-ended 1 V/ns DQ slew rate and 2 V/ns differential DK, DK# slew rate.
18. These parameters are measured from a data signal (DM, DQ0, DQ1, and so forth) transition edge to its respective data strobe signal (DK, DK#) crossing.
19. The setup and hold times are listed converting the base specification values (to which derating tables apply) to V_{REF} when the slew rate is 1 V/ns. These values, with a slew rate of 1 V/ns, are for reference only.
20. Pulse width of an input signal is defined as the width between the first crossing of $V_{REF(DC)}$ and the consecutive crossing of $V_{REF(DC)}$.
21. Mode Register 0 (MR0), bits [3:0] selects the number of clock cycles required to satisfy the minimum t_{RC} value. The value programmed into these bits must match one of the allowed combinations shown in the t_{RC_MRS} table.
22. t_{QKQ02} defines the skew between QK0 and DQ[26:18] and between QK2 and DQ[8:0]. t_{QKQ13} defines the skew between QK1 and DQ[35:27] and between QK3 and DQ[17:9].
23. When the device is operated with input clock jitter, this parameter needs to be derated by the actual $t_{JIT(per)}$ (the larger of $t_{JIT(per),min}$ or $t_{JIT(per),max}$ of the input clock; output deratings are relative to the SDRAM input clock).
24. Single-ended signal parameter.
25. For x36 device this specification references the skew between the falling edge of QK0 and QK1 to QVLD0 and the falling edge of QK2 and QK3 to QVLD1.
26. The DRAM output timing is aligned to the nominal or average clock. The following output parameters must be derated by the actual jitter error when input clock jitter is present, even when within specification. This results in each parameter becoming larger. The following parameters are required to be derated by subtracting $t_{ERR(10per),max}$: $t_{CKQK (MIN)}$, and $t_{LZ (MIN)}$. The following parameters are required to be derated by subtracting $t_{ERR(10per),min}$: $t_{CKQK (MAX)}$, $t_{HZ (MAX)}$, and $t_{LZ (MAX)}$.
27. The $t_{DQSCkdl_dis}$ parameter begins RL - 1 cycles after the READ command.
28. $t_{IS(base)}$ and $t_{IH(base)}$ values are for a single-ended 1 V/ns control/command/address slew rate and 2 V/ns CK, CK# differential slew rate.
29. These parameters are measured from the input data strobe signal (DK/DK#) crossing to its respective clock signal crossing (CK/CK#). The specification values are not affected by the amount of clock jitter applied as they are relative to the clock signal crossing. These parameters should be met whether or not clock jitter is present.
30. These parameters are measured from a command/address signal transition edge to its respective clock (CK, CK#) signal crossing. The specification values are not affected by the amount of clock jitter applied as the setup and hold times are relative to the clock signal crossing that latches the command/address. These parameters should be met whether or not clock jitter is present.
31. RESET# should be LOW as soon as power starts to ramp to ensure the outputs are in High-Z. Until RESET# is LOW, the outputs are at risk of driving and could result in excessive current, depending on bus activity.



32. If t^{WTR} is violated, the data just written will not be read out when a READ command is issued to the same address. Whatever data was previously written to the address will be output with the READ command.
33. This specification is defined as any bank command (READ, WRITE, AREF) to a multi-bank command or a multi-bank command to any bank command. This specification only applies to quad bank WRITE, 3-bank AREF and 4-bank AREF commands. Dual bank WRITE, 2-bank AREF, and all single bank access commands are not bound by this specification.
34. DRAM devices should be evenly addressed when being accessed. Disproportionate accesses to a particular row address may result in a reduction of REFRESH characteristics or product lifetime.

Temperature and Thermal Impedance Characteristics

It is imperative that the device's temperature specifications be maintained in order to ensure that the junction temperature is in the proper operating range to meet data sheet specifications. An important way to maintain the proper junction temperature is to use the device's thermal impedances correctly. Thermal impedances are listed for the available packages.

Incorrectly using thermal impedances can produce significant errors.

The device's safe junction temperature range can be maintained when the T_C specification is not exceeded. In applications where the device's ambient temperature is too high, use of forced air and/or heat sinks may be required in order to meet the case temperature specifications.

Table 28: Temperature Limits

Parameter		Symbol	Min	Max	Units	Notes
Storage temperature		T_{STG}	-55	150	°C	1
Reliability junction temperature	Commercial	$T_{J(REL)}$	-	110	°C	2
	Industrial		-	110	°C	2
Operating junction temperature	Commercial	$T_{J(OP)}$	0	100	°C	3
	Industrial		-40	100	°C	3
Operating case temperature	Commercial	T_C	0	95	°C	4, 5
	Industrial		-40	95	°C	4, 5

- Notes:
1. MAX storage case temperature; T_{STG} is measured in the center of the package (see Figure 21). This case temperature limit is allowed to be exceeded briefly during package reflow.
 2. Temperatures greater than 110°C may cause permanent damage to the device. This is a stress rating only and functional operation of the device at or above this is not implied. Exposure to absolute maximum rating conditions for extended periods may adversely affect the reliability of the part.
 3. Junction temperature depends upon package type, cycle time, loading, ambient temperature, and airflow.
 4. MAX operating case temperature; T_C is measured in the center of the package (see Figure 21).
 5. Device functionality is not guaranteed if the device exceeds maximum T_C during operation.



Table 29: Thermal Impedance

Package	Theta-JA Airflow = 0m/s	Theta-JA Airflow = 1m/s	Theta-JA Airflow = 2m/s	Theta-JB	Theta-JC	Units
168-ball BGA	17.2	15.4	13.7	4.3	3.2	°C/W

Note:

Follows method defined by JE5D51, with 4-layer substrate

Figure 21: Example Temperature Test Point Location

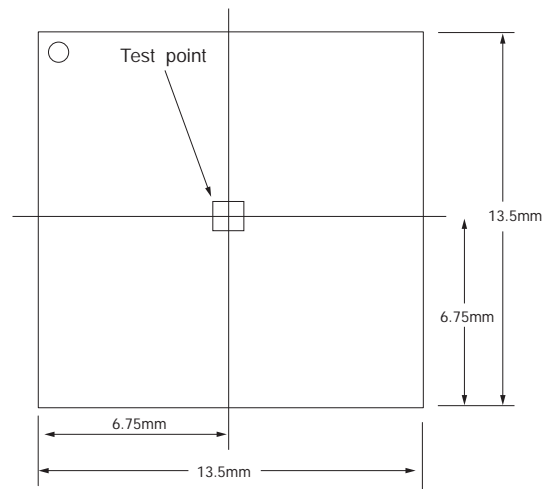



Command and Address Setup, Hold, and Derating

The total t_{IS} (setup time) and t_{IH} (hold time) required is calculated by adding the data sheet t_{IS} (base) and t_{IH} (base) values (see Table 31 ; values come from Table 28) to the Δt_{IS} and Δt_{IH} derating values (see Table 32, respectively. Example: t_{IS} (total setup time) = t_{IS} (base) + Δt_{IS} . For a valid transition, the input signal must remain above/below $V_{IH(AC)}/V_{IL(AC)}$ for some time t_{VAC} (see Table 33).

Although the total setup time for slow slew rates might be negative (for example, a valid input signal will not have reached $V_{IH(AC)}/V_{IL(AC)}$ at the time of the rising clock transition), a valid input signal is still required to complete the transition and to reach $V_{IH(AC)}/V_{IL(AC)}$. For slew rates which fall between the values listed in Table 32 and Table 33 for Valid Transition, the derating values may be obtained by linear interpolation.

Setup (t_{IS}) nominal slew rate for a rising signal is defined as the slew rate between the last crossing of $V_{REF(DC)}$ and the first crossing of $V_{IH(AC)min}$. Setup (t_{IS}) nominal slew rate for a falling signal is defined as the slew rate between the last crossing of $V_{REF(DC)}$ and the first crossing of $V_{IL(AC)max}$. If the actual signal is always earlier than the nominal slew rate line between the shaded $V_{REF(DC)}$ -to-AC region, use the nominal slew rate for derating value (see Figure 22). If the actual signal is later than the nominal slew rate line anywhere between the shaded $V_{REF(DC)}$ -to-AC region, the slew rate of a tangent line to the actual signal from the AC level to the DC level is used for derating value (see Figure 24).

Hold (t_{IH}) nominal slew rate for a rising signal is defined as the slew rate between the last crossing of $V_{IL(DC)max}$ and the first crossing of $V_{REF(DC)}$. Hold (t_{IH}) nominal slew rate for a falling signal is defined as the slew rate between the last crossing of $V_{IH(DC)min}$ and the first crossing of $V_{REF(DC)}$. If the actual signal is always later than the nominal slew rate line between the shaded DC-to- $V_{REF(DC)}$ region, use the nominal slew rate for derating value (see Figure 23). If the actual signal is earlier than the nominal slew rate

line anywhere between the shaded DC-to- $V_{REF(DC)}$ region, the slew rate of a tangent line to the actual signal from the DC level to the $V_{REF(DC)}$ level is used for derating value (see Figure 25).

Table 30: Command and Address Setup and Hold Values Referenced at 1 V/ns – AC/DC-Based

Symbol	RL3-2400	RL3-2133	RL3-1866	Units	Reference
$t_{IS}(\text{base}), AC150$	70	85	120	ps	$V_{IH(AC)}/V_{IL(AC)}$
$t_{IS}(\text{base}), AC135$	85	100	135	ps	$V_{IH(AC)}/V_{IL(AC)}$
$t_{IS}(\text{base}), AC120$	100	115	150	ps	$V_{IH(AC)}/V_{IL(AC)}$
$t_{IH}(\text{base}), DC100$	50	65	100	ps	$V_{IH(DC)}/V_{IL(DC)}$



Table 31: Derating Values for t^1IS/t^1IH – AC150/DC100-Based

Δ^1IS, Δ^1IH Derating (ps) - AC/DC-Based AC 150 Threshold: $V_{IH(AC)} = V_{REF(DC)} + 150mV, V_{IL(AC)} = V_{REF(DC)} - 150mV$																
CMD/ADDR Slew Rate (V/ns)	CK, CK# Differential Slew Rate															
	4.0 V/ns		3.0 V/ns		2.0 V/ns		1.8 V/ns		1.6 V/ns		1.4 V/ns		1.2 V/ns		1.0 V/ns	
	Δ^1IS	Δ^1IH	Δ^1IS	Δ^1IH	Δ^1IS	Δ^1IH	Δ^1IS	Δ^1IH	Δ^1IS	Δ^1IH	Δ^1IS	Δ^1IH	Δ^1IS	Δ^1IH	Δ^1IS	Δ^1IH
2.0	75	50	75	50	75	50	83	58	91	66	99	74	107	84	115	100
1.5	50	34	50	34	50	34	58	42	66	50	74	58	82	68	90	84
1.0	0	0	0	0	0	0	8	8	16	16	24	24	32	34	40	50
0.9	0	-4	0	-4	0	-4	8	4	16	12	24	20	32	30	40	46
0.8	0	-10	0	-10	0	-10	8	-2	16	6	24	14	32	24	40	40
0.7	0	-16	0	-16	0	-16	8	-8	16	0	24	8	32	18	40	34
0.6	-1	-26	-1	-26	-1	-26	7	-18	15	-10	23	-2	31	8	39	24
0.5	-10	-40	-10	-40	-10	-40	-2	-32	6	-24	14	-16	22	-6	30	10
0.4	-25	-60	-25	-60	-25	-60	-17	-52	-9	-44	-1	-36	7	-26	15	-10

Table 32: Derating Values for t^1IS/t^1IH – AC135/DC100-Based

Δ^1IS, Δ^1IH Derating (ps) - AC/DC-Based AC 135 Threshold: $V_{IH(AC)} = V_{REF(DC)} + 135mV, V_{IL(AC)} = V_{REF(DC)} - 135mV$																
CMD/ADDR Slew Rate (V/ns)	CK, CK# Differential Slew Rate															
	4.0 V/ns		3.0 V/ns		2.0 V/ns		1.8 V/ns		1.6 V/ns		1.4 V/ns		1.2 V/ns		1.0 V/ns	
	Δ^1IS	Δ^1IH	Δ^1IS	Δ^1IH	Δ^1IS	Δ^1IH	Δ^1IS	Δ^1IH	Δ^1IS	Δ^1IH	Δ^1IS	Δ^1IH	Δ^1IS	Δ^1IH	Δ^1IS	Δ^1IH
2.0	68	50	68	50	68	50	76	58	84	66	92	74	100	84	108	100
1.5	45	34	45	34	45	34	53	42	61	50	69	58	77	68	85	84
1.0	0	0	0	0	0	0	8	8	16	16	24	24	32	34	40	50
0.9	0	-4	0	-4	0	-4	8	4	16	12	24	20	32	30	40	46
0.8	0	-10	0	-10	0	-10	8	-2	16	6	24	14	32	24	40	40
0.7	0	-16	0	-16	0	-16	8	-8	16	0	24	8	32	18	40	34
0.6	-1	-26	-1	-26	-1	-26	7	-18	15	-10	23	-2	31	8	39	24
0.5	-10	-40	-10	-40	-10	-40	-2	-32	6	-24	14	-16	22	-6	30	10
0.4	-25	-60	-25	-60	-25	-60	-17	-52	-9	-44	-1	-36	7	-26	15	-10



Table 33: Derating Values for t_{IS}/t_{IH} – AC120/DC100-Based

$\Delta t_{IS}, \Delta t_{IH}$ Derating (ps) - AC/DC-Based AC 120 Threshold: $V_{IH(AC)} = V_{REF(DC)} + 120mV, V_{IL(AC)} = V_{REF(DC)} - 120mV$																
CMD/ADDR Slew Rate (V/ns)	CK, CK# Differential Slew Rate															
	4.0 V/ns		3.0 V/ns		2.0 V/ns		1.8 V/ns		1.6 V/ns		1.4 V/ns		1.2 V/ns		1.0 V/ns	
	Δt_{IS}	Δt_{IH}	Δt_{IS}	Δt_{IH}	Δt_{IS}	Δt_{IH}	Δt_{IS}	Δt_{IH}	Δt_{IS}	Δt_{IH}	Δt_{IS}	Δt_{IH}	Δt_{IS}	Δt_{IH}	Δt_{IS}	Δt_{IH}
2.0	60	50	60	50	60	50	68	58	76	66	84	74	92	84	100	100
1.5	40	34	40	34	40	34	48	42	56	50	64	58	72	68	80	84
1.0	0	0	0	0	0	0	8	8	16	16	24	24	32	34	40	50
0.9	0	-4	0	-4	0	-4	8	4	16	12	24	20	32	30	40	46
0.8	0	-10	0	-10	0	-10	8	-2	16	6	24	14	32	24	40	40
0.7	0	-16	0	-16	0	-16	8	-8	16	0	24	8	32	18	40	34
0.6	-1	-26	-1	-26	-1	-26	7	-18	15	-10	23	-2	31	8	39	24
0.5	-10	-40	-10	-40	-10	-40	-2	-32	6	-24	14	-16	22	-6	30	10
0.4	-25	-60	-25	-60	-25	-60	-17	-52	-9	-44	-1	-36	7	-26	15	-10

Table 34: Minimum Required Time t_{VAC} Above $V_{IH(AC)}$ (or Below $V_{IL(AC)}$) for Valid Transition

Slew Rate (V/ns)	t_{VAC} (ps)
>2.0	175
2.0	170
1.5	167
1.0	163
0.9	162
0.8	161
0.7	159
0.6	155
0.5	150
<0.5	150

Figure 22: Nominal Slew Rate and t_{VAC} for t_{IS} (Command and Address - Clock)

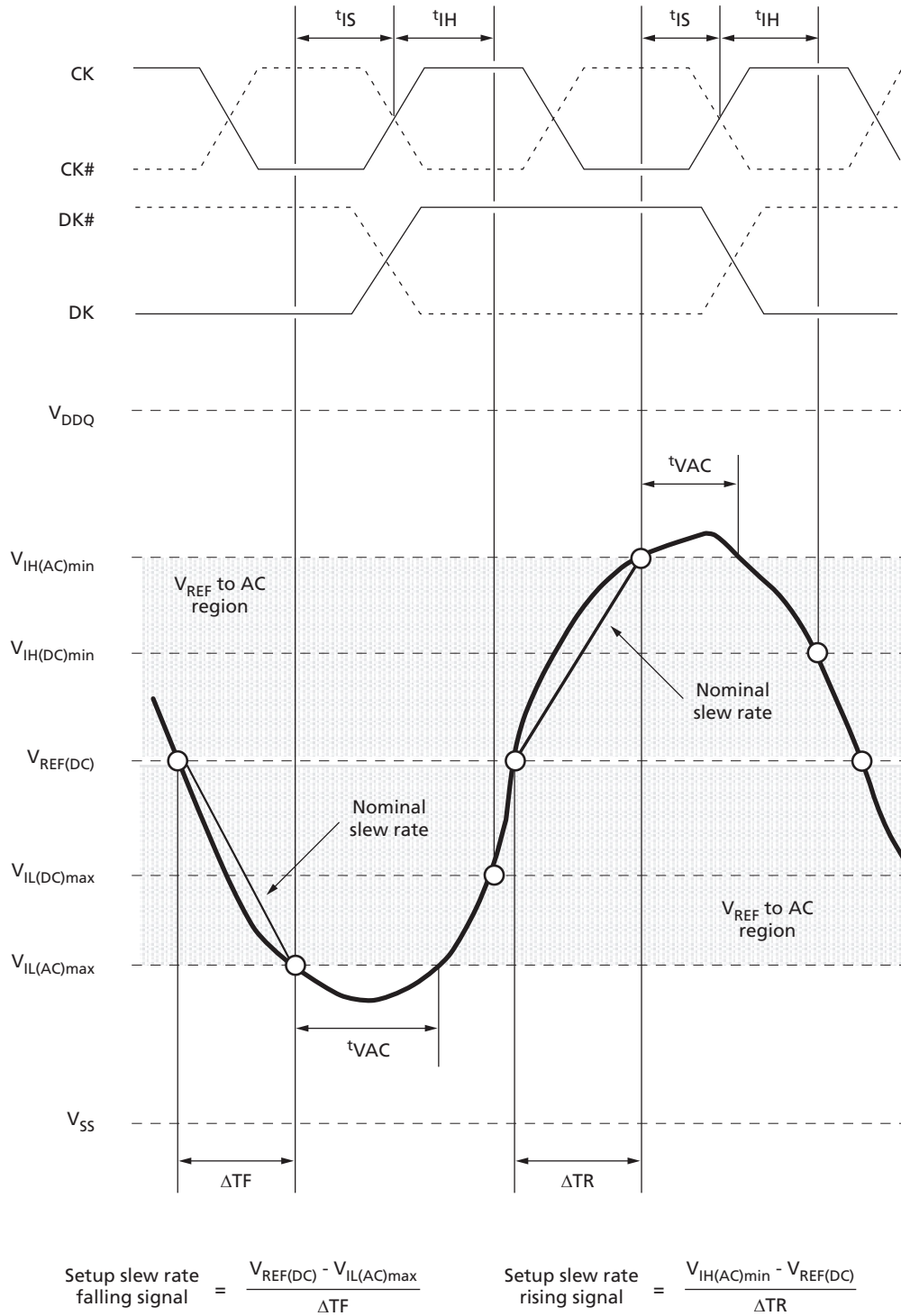

Note: 1. Both the clock and the data strobe are drawn on different time scales.

Figure 23: Nominal Slew Rate for t_{IH} (Command and Address - Clock)

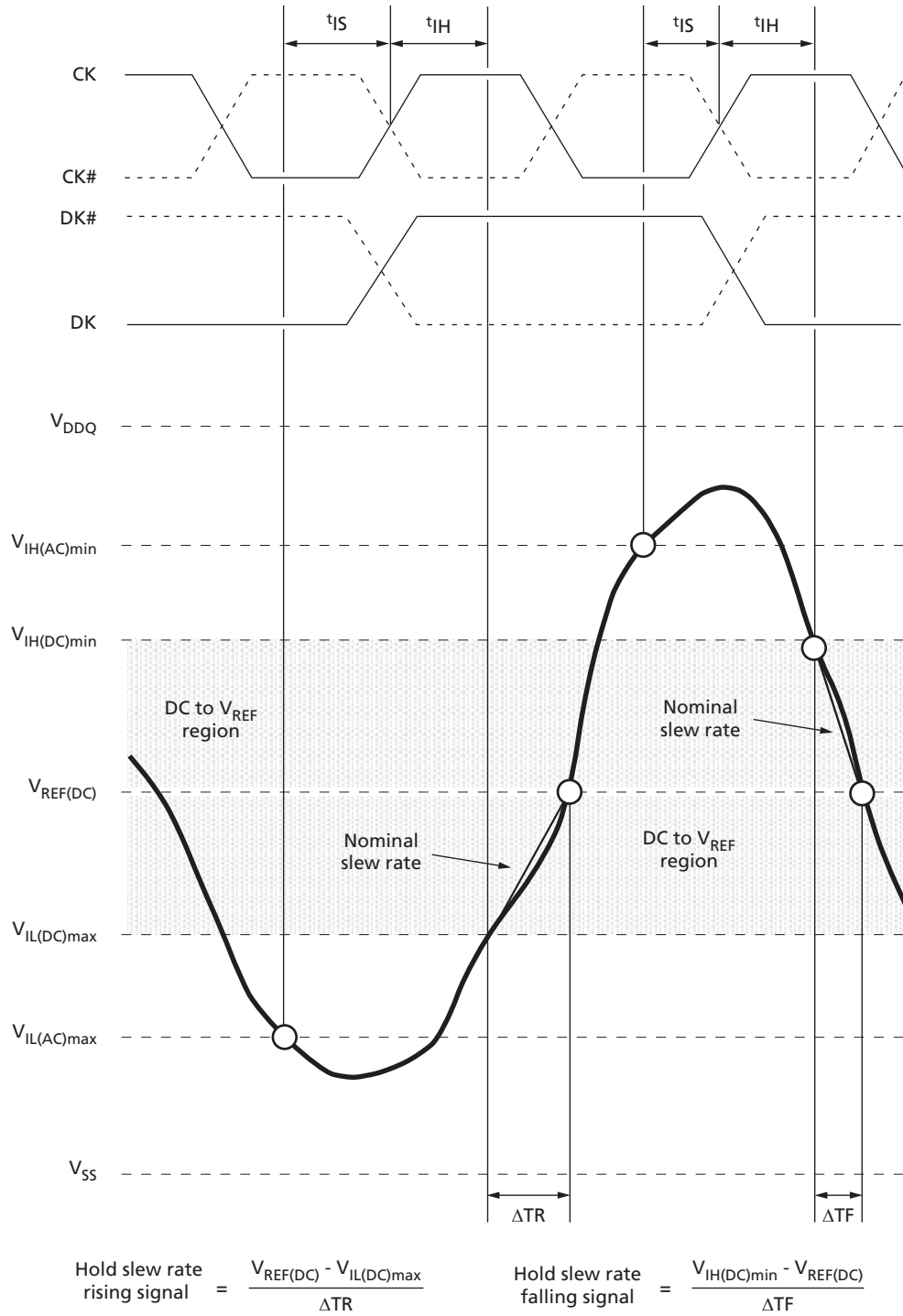

Note: 1. Both the clock and the data strobe are drawn on different time scales.

Figure 24: Tangent Line for t_{IS} (Command and Address - Clock)

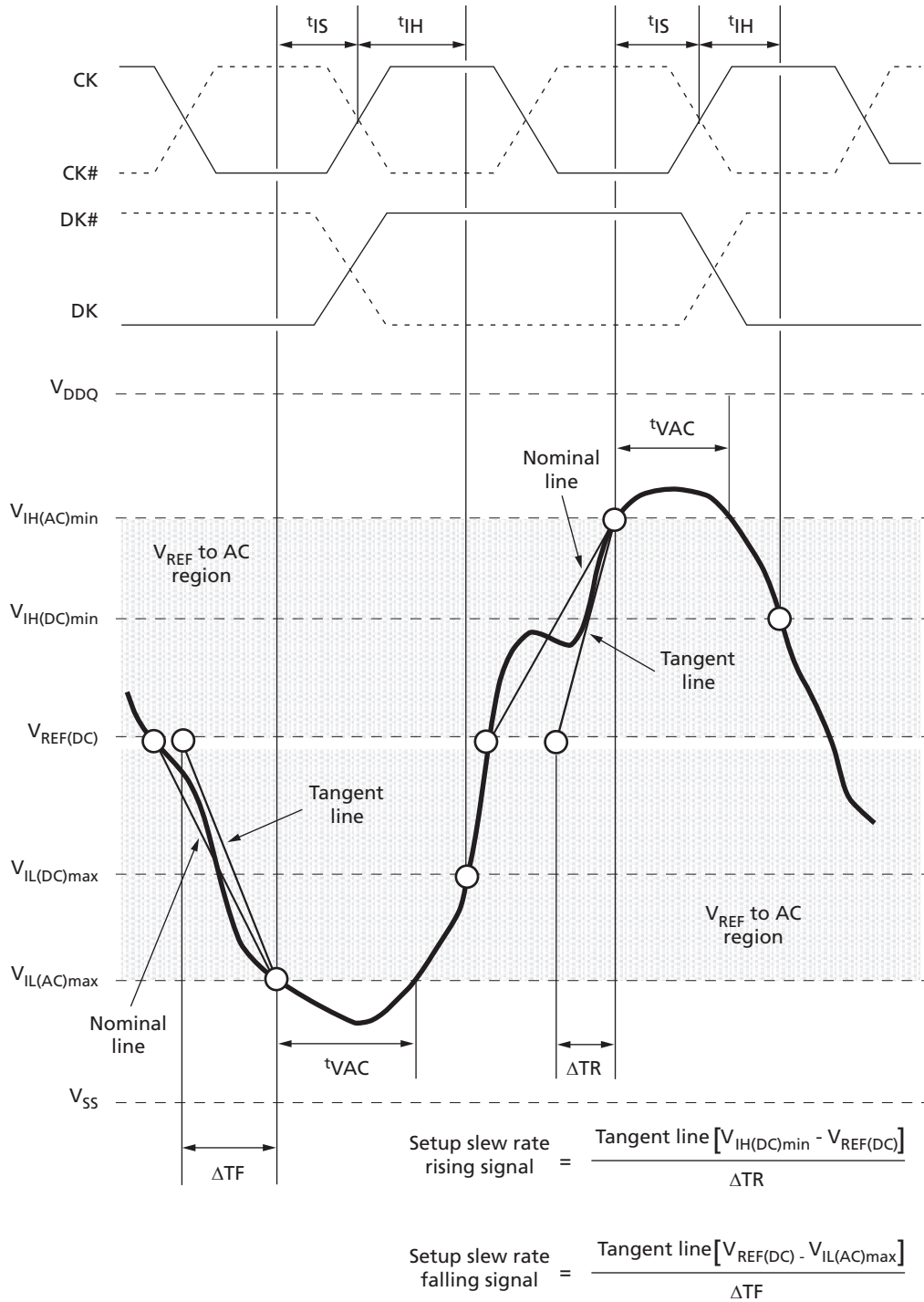

Note: 1. Both the clock and the data strobe are drawn on different time scales.

Figure 25: Tangent Line for t_{IH} (Command and Address - Clock)

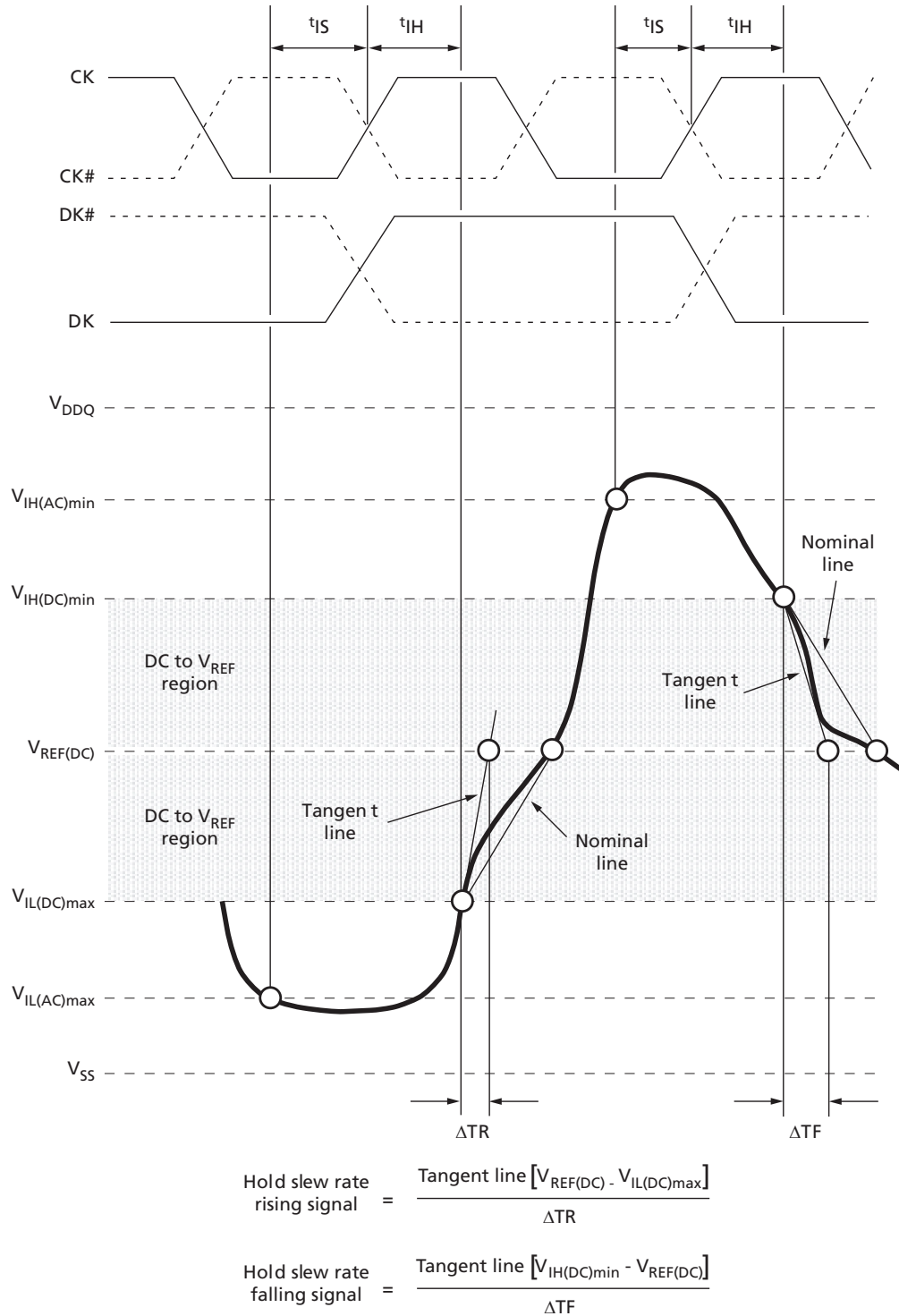

Note: 1. Both the clock and the data strobe are drawn on different time scales.



Data Setup, Hold, and Derating

The total t_{DS} (setup time) and t_{DH} (hold time) required is calculated by adding the data sheet t_{DS} (base) and t_{DH} (base) values (see the table below; values come from Table 28) to the Δt_{DS} and Δt_{DH} derating values (see Table 35), respectively. Example: t_{DS} (total setup time) = t_{DS} (base) + Δt_{DS} . For a valid transition, the input signal has to remain above/below $V_{IH(AC)}/V_{IL(AC)}$ for some time t_{VAC} (see Table 36).

Although the total setup time for slow slew rates might be negative (for example, a valid input signal will not have reached $V_{IH(AC)}/V_{IL(AC)}$ at the time of the rising clock transition), a valid input signal is still required to complete the transition and to reach $V_{IH}/V_{IL(AC)}$. For slew rates which fall between the values listed in Table 35 and Table 36, the derating values may be obtained by linear interpolation.

Setup (t_{DS}) nominal slew rate for a rising signal is defined as the slew rate between the last crossing of $V_{REF(DC)}$ and the first crossing of $V_{IH(AC)min}$. Setup (t_{DS}) nominal slew rate for a falling signal is defined as the slew rate between the last crossing of $V_{REF(DC)}$ and the first crossing of $V_{IL(AC)max}$. If the actual signal is always earlier than the nominal slew rate line between the shaded $V_{REF(DC)}$ -to-AC region, use the nominal slew rate for derating value (see Figure 26). If the actual signal is later than the nominal slew rate line anywhere between the shaded $V_{REF(DC)}$ -to-AC region, the slew rate of a tangent line to the actual signal from the AC level to the DC level is used for derating value (see Figure 28).

Hold (t_{DH}) nominal slew rate for a rising signal is defined as the slew rate between the last crossing of $V_{IL(DC)max}$ and the first crossing of $V_{REF(DC)}$. Hold (t_{DH}) nominal slew rate for a falling signal is defined as the slew rate between the last crossing of $V_{IH(DC)min}$ and the first crossing of $V_{REF(DC)}$. If the actual signal is always later than the nominal slew rate line between the shaded DC-to- $V_{REF(DC)}$ region, use the nominal slew rate for derating value (see Figure 27). If the actual signal is earlier than the nominal slew rate line anywhere between the shaded DC-to- $V_{REF(DC)}$ region, the slew rate of a tangent line to the actual signal from the DC-to- $V_{REF(DC)}$ region is used for derating value (see Figure 29).

Table 35: Data Setup and Hold Values (DKx, DKx# at 2 V/ns) – AC/DC-Based

Symbol	RL3-2400	RL3-2133	RL3-1866	Units	Reference
$t_{DS}(\text{base}), AC150$ at 1 V/ns	-35	-30	-15	ps	$V_{IH(AC)}/V_{IL(AC)}$
$t_{DS}(\text{base}), AC135$ at 2 V/ns	48	53	68	ps	$V_{IH(AC)}/V_{IL(AC)}$
$t_{DS}(\text{base}), AC120$ at 2 V/ns	55	60	75	ps	$V_{IH(AC)}/V_{IL(AC)}$
$t_{DH}(\text{base}), DC100$ at 1 V/ns	0	5	20	ps	$V_{IH(DC)}/V_{IL(DC)}$
$t_{DH}(\text{base}), DC100$ at 2 V/ns	50	55	70	ps	$V_{IH(DC)}/V_{IL(DC)}$



Table 36: Derating Values for t_{DS}/t_{DH} – AC150/DC100-Based

Empty cells indicate slew rate combinations not supported

Δ^tDS, Δ^tDH Derating (ps) - AC/DC-Based																
DQ Slew Rate (V/ns)	DKx, DKx# Differential Slew Rate															
	4.0 V/ns		3.0 V/ns		2.0 V/ns		1.8 V/ns		1.6 V/ns		1.4 V/ns		1.2 V/ns		1.0 V/ns	
	Δ^tDS	Δ^tDH	Δ^tDS	Δ^tDH	Δ^tDS	Δ^tDH	Δ^tDS	Δ^tDH	Δ^tDS	Δ^tDH	Δ^tDS	Δ^tDH	Δ^tDS	Δ^tDH	Δ^tDS	Δ^tDH
2.0	75	50	75	50	75	50										
1.5	50	34	50	34	50	34	58	42								
1.0	0	0	0	0	0	0	8	8	16	16						
0.9			0	-4	0	-4	8	4	16	12	24	20				
0.8					0	-10	8	-2	16	6	24	14	32	24		
0.7							8	-8	16	0	24	8	32	18	40	34
0.6									15	-10	23	-2	31	8	39	24
0.5											14	-16	22	-6	30	10
0.4													7	-26	15	-10

Table 37: Derating Values for t_{DS}/t_{DH} – AC135/DC100-Based

Empty cells indicate slew rate combinations not supported

Δ^tDS, Δ^tDH Derating (ps) - AC/DC-Based																
DQ Slew Rate (V/ns)	DKx, DKx# Differential Slew Rate															
	8.0 V/ns		7.0 V/ns		6.0 V/ns		5.0 V/ns		4.0 V/ns		3.0 V/ns		2.0 V/ns		1.8 V/ns	
	Δ^tDS	Δ^tDH	Δ^tDS	Δ^tDH	Δ^tDS	Δ^tDH	Δ^tDS	Δ^tDH	Δ^tDS	Δ^tDH	Δ^tDS	Δ^tDH	Δ^tDS	Δ^tDH	Δ^tDS	Δ^tDH
4.0	34	25	34	25	34	25										
3.5	29	22	29	22	29	22	29	22								
3.0	23	17	23	17	23	17	23	17	23	17						
2.5			14	10	14	10	14	10	14	10	14	10				
2.0					0	0	0	0	0	0	0	0	0	0		
1.5							-23	-16	-23	-16	-23	-16	-23	-16	-15	-8
1.0									-68	-50	-68	-50	-68	-50	-60	-42
0.9											-68	-50	-68	-50	-60	-42
0.8													-68	-50	-60	-42



Table 38: Derating Values for t_{DS}/t_{DH} – AC120/DC100-Based

Empty cells indicate slew rate combinations not supported

$\Delta t_{DS}, \Delta t_{DH}$ Derating (ps) - AC/DC-Based																
DQ Slew Rate (V/ns)	DKx, DKx# Differential Slew Rate															
	8.0 V/ns		7.0 V/ns		6.0 V/ns		5.0 V/ns		4.0 V/ns		3.0 V/ns		2.0 V/ns		1.8 V/ns	
	Δt_{DS}	Δt_{DH}	Δt_{DS}	Δt_{DH}	Δt_{DS}	Δt_{DH}	Δt_{DS}	Δt_{DH}	Δt_{DS}	Δt_{DH}	Δt_{DS}	Δt_{DH}	Δt_{DS}	Δt_{DH}	Δt_{DS}	Δt_{DH}
4.0	30	25	30	25	30	25										
3.5	26	22	26	22	26	22	26	22								
3.0	20	17	20	17	20	17	20	17	20	17						
2.5			12	10	12	10	12	10	12	10	12	10				
2.0					0	0	0	0	0	0	0	0	0	0		
1.5							-20	-16	-20	-16	-20	-16	-20	-16	-12	-8
1.0									-60	-50	-60	-50	-60	-50	-52	-42
0.9											-60	-50	-60	-50	-52	-42
0.8													-60	-50	-52	-42

Table 39: Minimum Required Time t_{VAC} Above $V_{IH(AC)}$ (or Below $V_{IL(AC)}$) for Valid Transition

Slew Rate (V/ns)	t_{VAC} (ps)
>2.0	175
2.0	170
1.5	167
1.0	163
0.9	162
0.8	161
0.7	159
0.6	155
0.5	150
<0.5	150

Figure 26: Nominal Slew Rate and t_{VAC} for t_{DS} (DQ - Strobe)

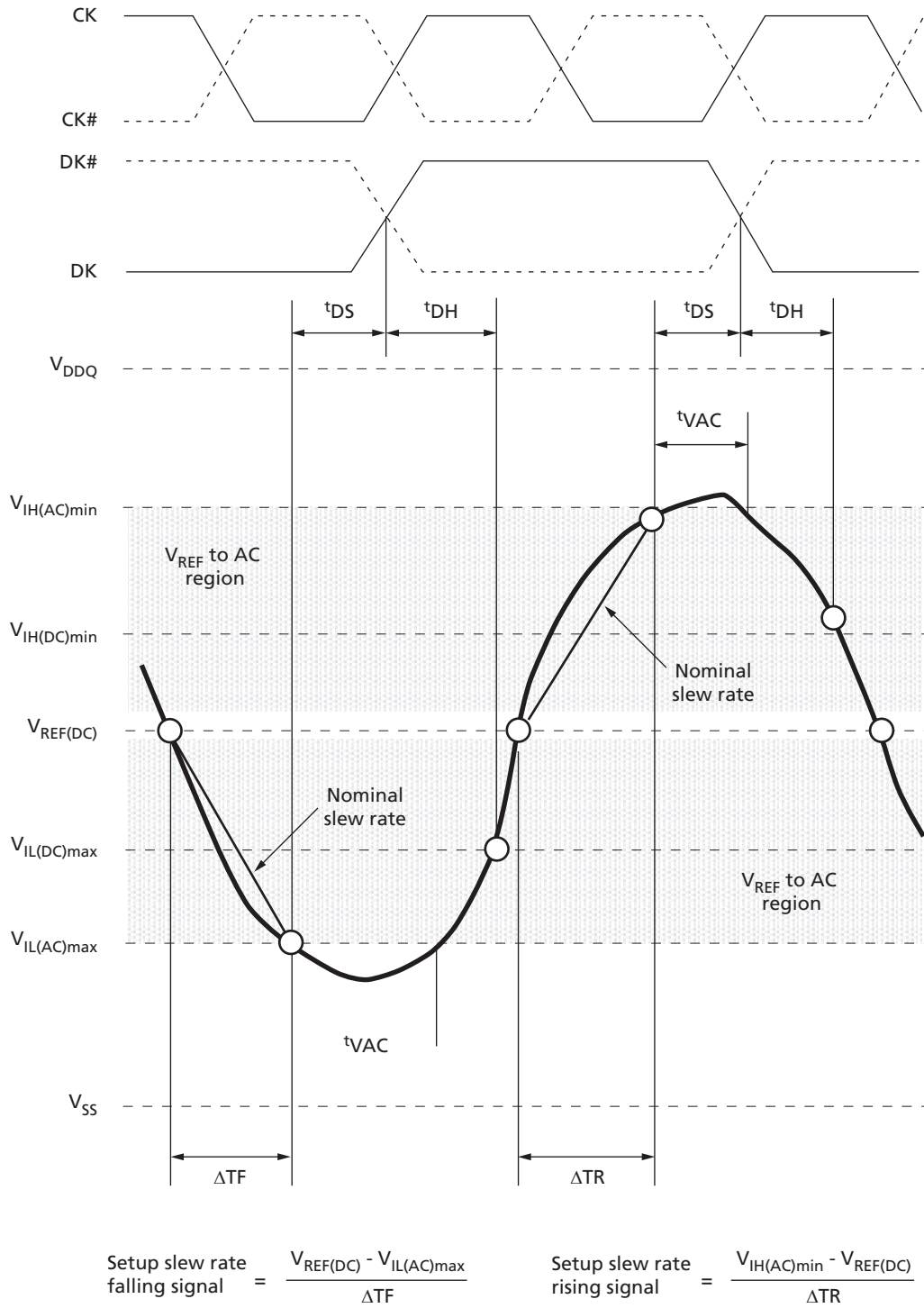

Note: 1. Both the clock and the strobe are drawn on different time scales.

Figure 27: Nominal Slew Rate for t_{DH} (DQ - Strobe)

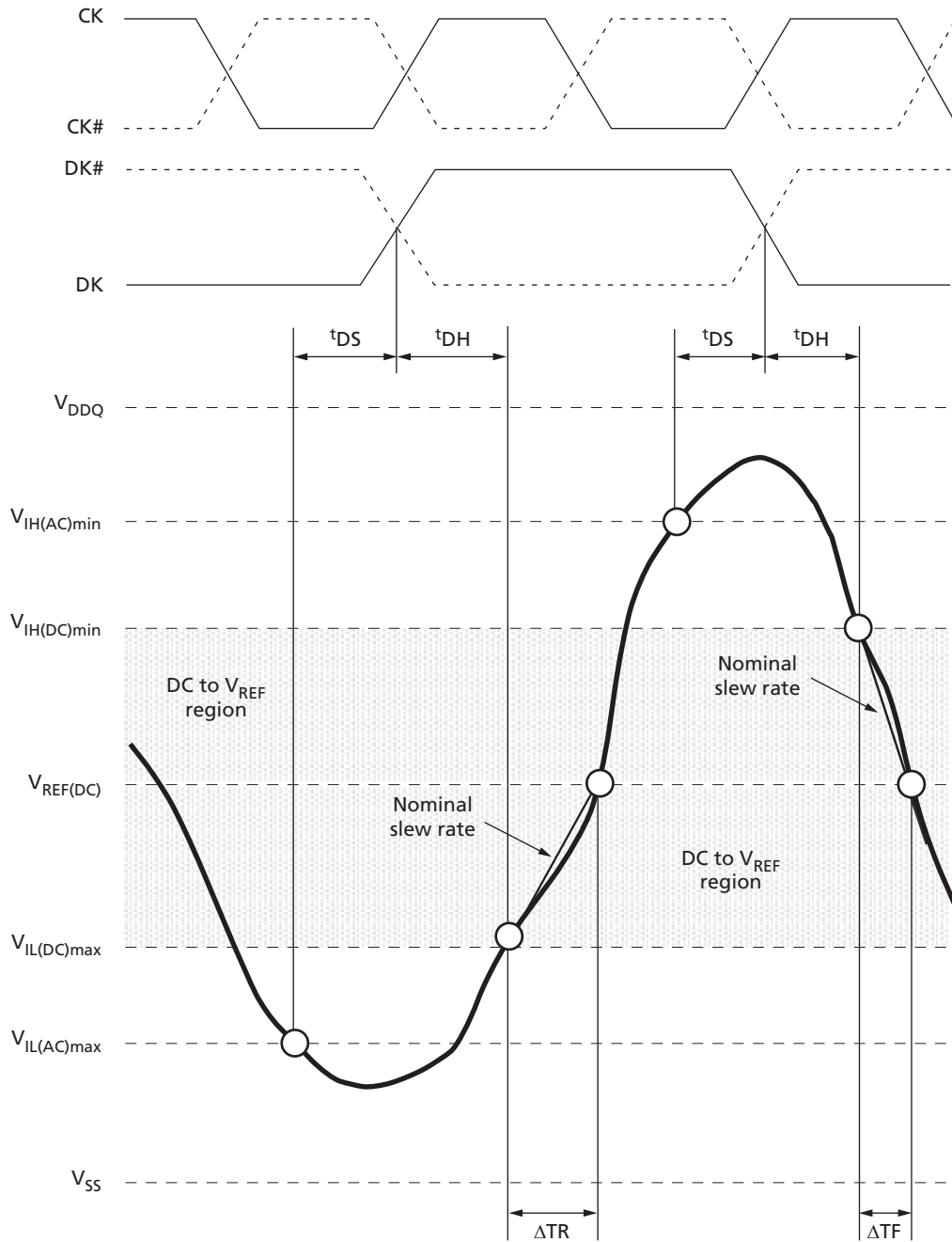

$$\text{Hold slew rate rising signal} = \frac{V_{REF(DC)} - V_{IL(DC)max}}{\Delta TR}$$

$$\text{Hold slew rate falling signal} = \frac{V_{IH(DC)min} - V_{REF(DC)}}{\Delta TF}$$

Note: 1. Both the clock and the strobe are drawn on different time scales.

Figure 28: Tangent Line for t_{DS} (DQ - Strobe)

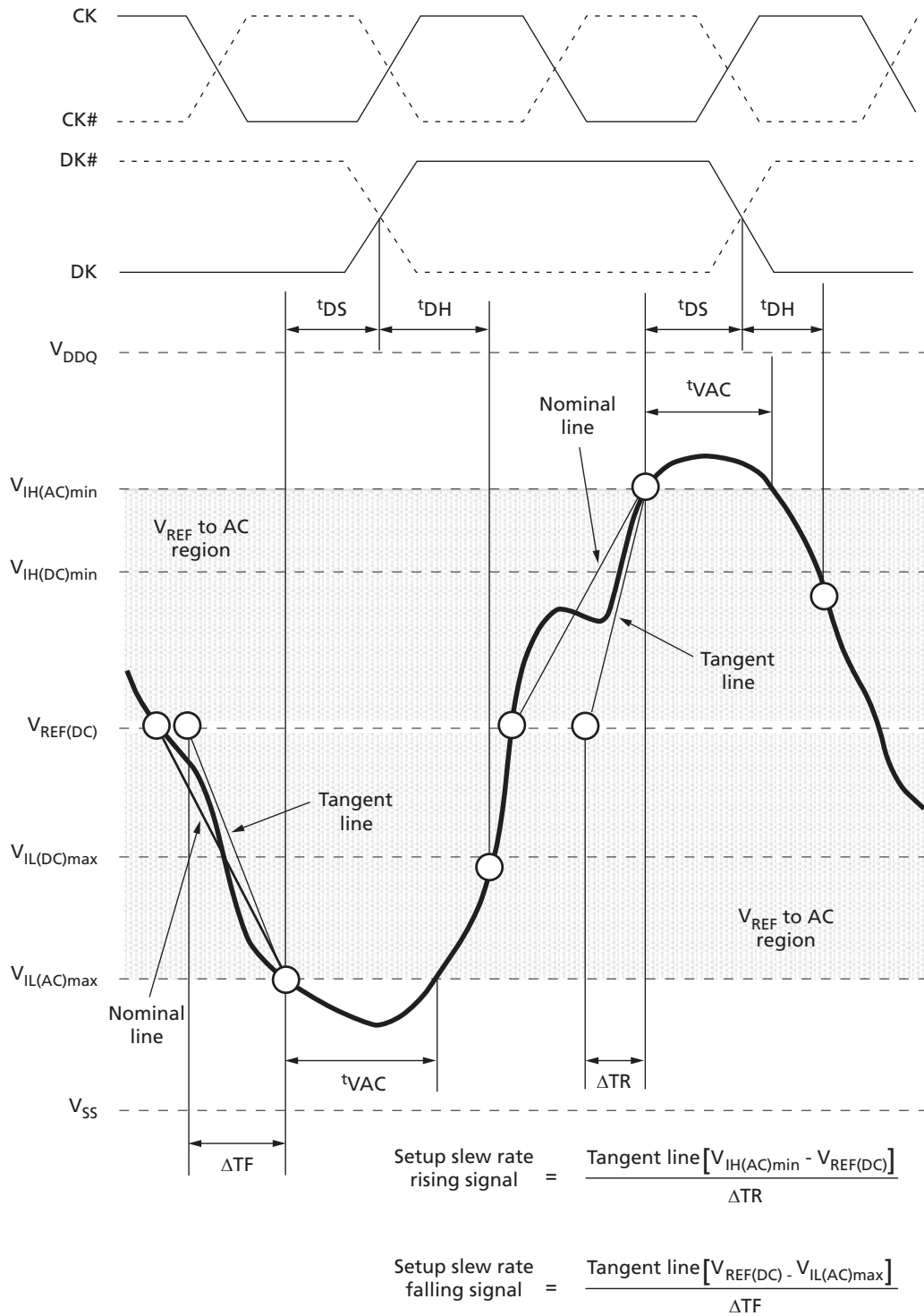

Note: 1. Both the clock and the strobe are drawn on different time scales.

Figure 29: Tangent Line for t_{DH} (DQ - Strobe)

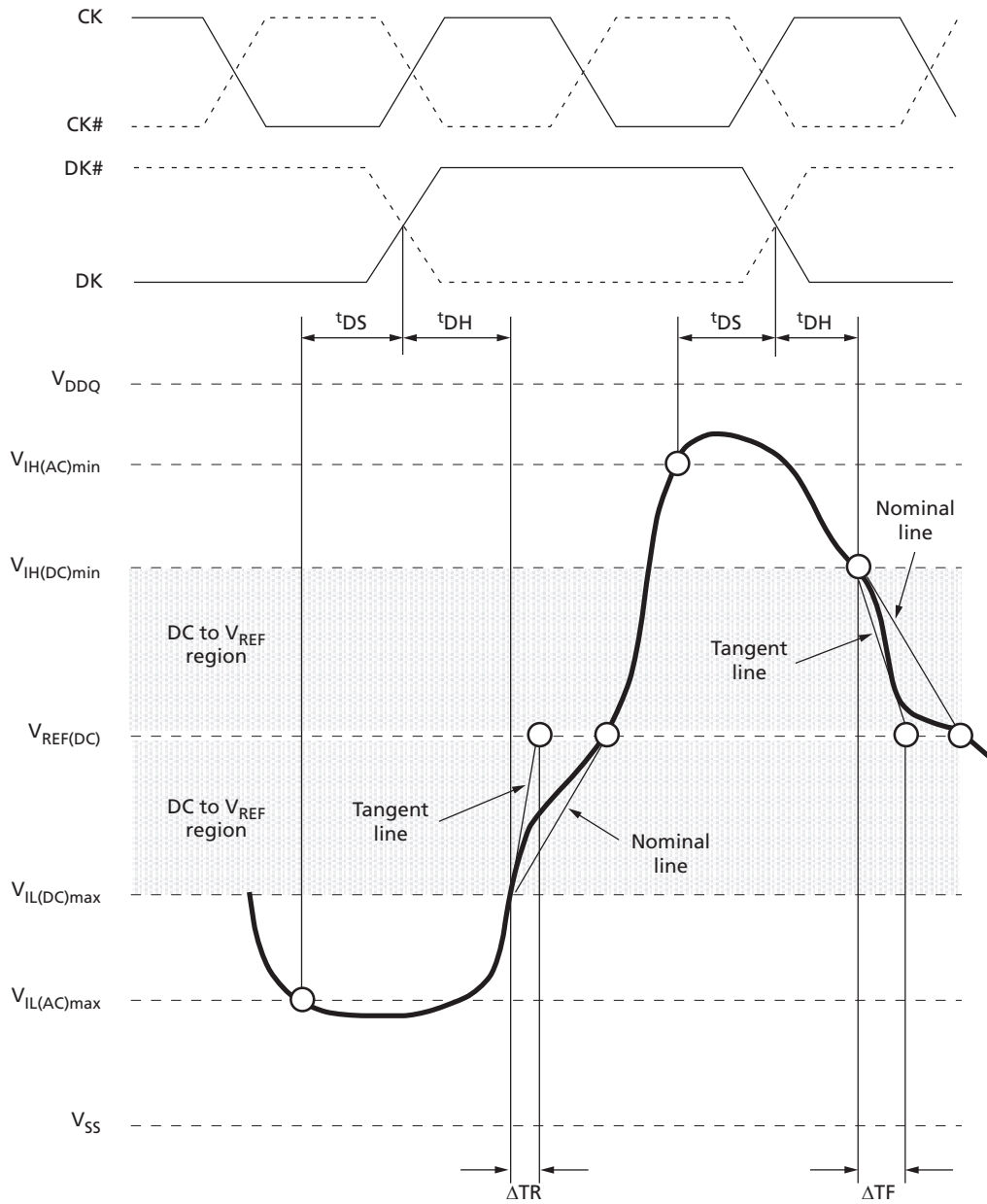

$$\text{Hold slew rate rising signal} = \frac{\text{Tangent line} [V_{REF(DC)} - V_{IL(DC)max}]}{\Delta TR}$$

$$\text{Hold slew rate falling signal} = \frac{\text{Tangent line} [V_{IH(DC)min} - V_{REF(DC)}]}{\Delta TF}$$

Note: 1. Both the clock and the strobe are drawn on different time scales.



Commands

The following table provides descriptions of the valid commands of the RLDRAM 3 device. All command and address inputs must meet setup and hold times with respect to the rising edge of CK.

Table 40: Command Descriptions

Command	Description
NOP	The NOP command prevents new commands from being executed by the DRAM. Operations already in progress are not affected by NOP commands. Output values depend on command history.
MRS	Mode registers MR0, MR1, and MR2 are used to define various modes of programmable operations of the DRAM. A mode register is programmed via the MODE REGISTER SET (MRS) command during initialization and retains the stored information until it is reprogrammed, RESET# goes LOW, or until the device loses power. The MRS command can be issued only when all banks are idle, and no bursts are in progress.
READ	The READ command is used to initiate a burst read access to a bank. The BA[3:0] inputs select a bank, and the address provided on inputs A[19:0] select a specific location within a bank.
WRITE	The WRITE command is used to initiate a burst write access to a bank (or banks). MRS bits MR2[4:3] select single, dual, or quad bank WRITE protocol. The BA[x:0] inputs select the bank(s) (x = 3, 2, or 1 for single, dual, or quad bank WRITE, respectively). The address provided on inputs A[19:0] select a specific location within the bank. Input data appearing on the DQ is written to the memory array subject to the DM input logic level appearing coincident with the data. If the DM signal is registered LOW, the corresponding data will be written to memory. If the DM signal is registered HIGH, the corresponding data inputs will be ignored (that is, this part of the data word will not be written).
AREF	The AREF command is used during normal operation of the RLDRAM 3 to refresh the memory content of a bank. There are two methods by which the RLDRAM 3 can be refreshed, both of which are selected within the mode register. The first method, bank address-controlled AREF, is identical to the method used in RLDRAM2. The second method, multibank AREF, enables refreshing of up to four banks simultaneously. More info is available in the Auto Refresh section. For both methods, the command is nonpersistent, so it must be issued each time a refresh is required.

Table 41: Command Table

Note 1 applies to the entire table

Operation	Code	CS#	WE#	REF#	A[19:0]	BA[3:0]	Notes
NOP	NOP	H	X	X	X	X	
MRS	MRS	L	L	L	OPCODE	OPCODE	
READ	READ	L	H	H	A	BA	2
WRITE	WRITE	L	L	H	A	BA	2
AUTO REFRESH	AREF	L	H	L	A	BA	3

- Notes:
1. X = "Don't Care;" H = logic HIGH; L = logic LOW; A = valid address; BA = valid bank address; OPCODE = mode register bits
 2. Address width varies with burst length and configuration; see the Address Widths of Different Burst Lengths table for more information.
 3. Bank address signals (BA) are used only during bank address-controlled AREF; Address signals (A) are used only during multibank AREF.

MODE REGISTER SET (MRS) Command

The mode registers, MR0, MR1, and MR2, store the data for controlling the operating modes of the memory. The MODE REGISTER SET (MRS) command programs the RLDRAM 3 operating modes and I/O options. During an MRS command, the address inputs are sampled and stored in the mode registers. The BA[1:0] signals select between mode registers 0–2 (MR0–MR2). After the MRS command is issued, each mode register retains the stored information until it is reprogrammed, until RESET# goes LOW, or until the device loses power.

After issuing a valid MRS command, ^tMRSC must be met before any command can be issued to the RLDRAM 3. The MRS command can be issued only when all banks are idle, and no bursts are in progress.

Figure 30: MRS Command Protocol

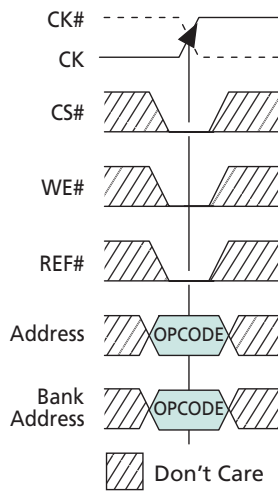

Mode Register 0 (MR0)

Figure 31: MR0 Definition for Non-Multiplexed Address Mode

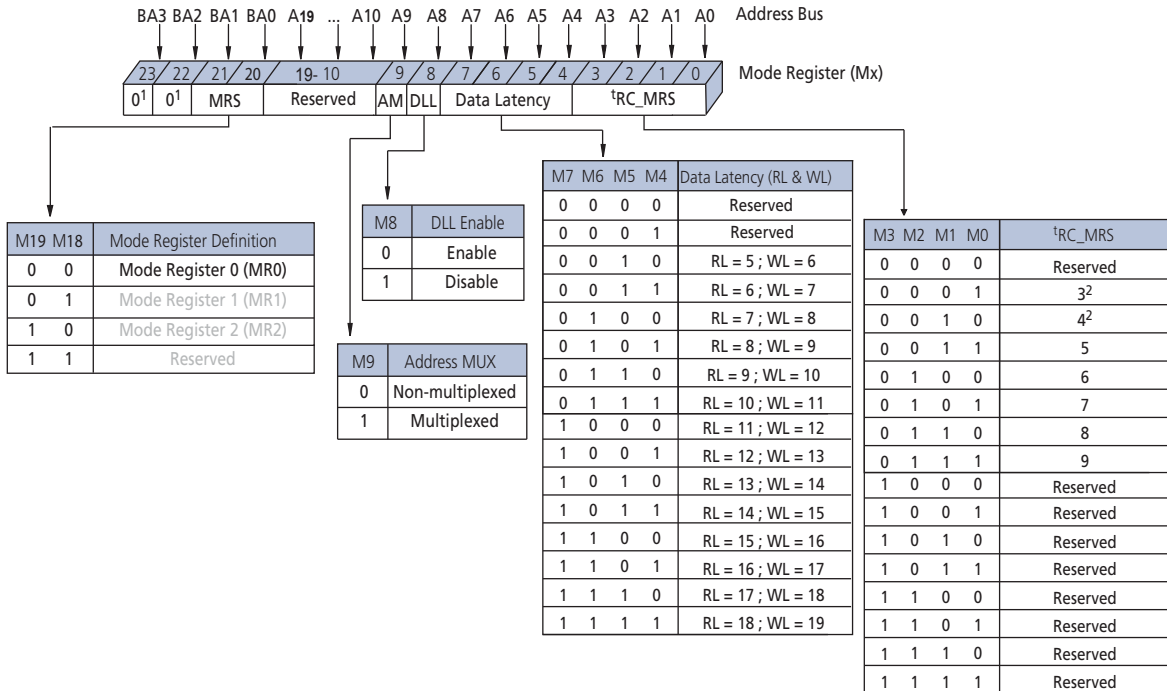

- Notes:
1. BA2, BA3, and all address balls corresponding to reserved bits must be held LOW during the MRS command.
 2. BL8 not allowed.



t¹RC

Bits MR0[3:0] select the number of clock cycles required to satisfy the t¹RC specifications.

After a READ, WRITE, or AREF command is issued to a bank, a subsequent READ, WRITE, or AREF cannot be issued to the same bank until t¹RC has been satisfied. The correct value (t¹RC_MRS) to program into MR0[3:0] is shown in the table below.

Table 42: t¹RC_MRS MR0[3:0] Values

Parameter	-083F	-083E	-093F	-093E	-107E
RL = 5; WL = 6	3	3	3	3	3
RL = 6; WL = 7	3	3	3	4	3
RL = 7; WL = 8	3	3	3	4	4
RL = 8; WL = 9	4	4	4	5	4
RL = 9; WL = 10	4	4	4	5	5
RL = 10; WL = 11	5	5	5	6	5
RL = 11; WL = 12	5	5	5	6	6
RL = 12; WL = 13	6	6	6	7	6
RL = 13; WL = 14	6	6	6	7	7
RL = 14; WL = 15	7	8	8	8	7
RL = 15; WL = 16	7	8	8	8	8
RL = 16; WL = 17	8	8	8	9	Reserved
RL = 17; WL = 18	8	8	8	9	Reserved
RL = 18; WL = 19	8	9	Reserved	Reserved	Reserved

Data Latency

The data latency register uses MR0[7:4] to set both the READ and WRITE latency (RL and WL). The valid operating frequencies for each data latency register setting can be found in Table 28.

DLL Enable/Disable

Through the programming of MR0[8], the DLL can be enabled or disabled.

The DLL must be enabled for normal operation. The DLL must be enabled during the initialization routine and upon returning to normal operation after having been disabled for the purpose of debugging or evaluation. To operate the RLD RAM with the DLL disabled, the t¹RC MRS setting must equal the read latency (RL) setting. Enabling the DLL should always be followed by resetting the DLL using the appropriate MR1 command.



Address Multiplexing

Although the RLD RAM has the ability to operate similar to an SRAM interface by accepting the entire address in one clock (non-multiplexed, or broadside addressing), MR0[9] can be set to 1 so that it functions with multiplexed addressing, similar to a traditional DRAM. In multiplexed address mode, the address is provided to the RLD RAM in two parts that are latched into the memory with two consecutive rising edges of CK.

When in multiplexed address mode, only 11 address balls are required to control the RLD RAM, as opposed to 20 address balls when in non-multiplexed address mode. The data bus efficiency in continuous burst mode is only affected when using the BL = 2 setting because the device requires two clocks to read and write data. During multiplexed mode, the bank addresses as well as WRITE and READ commands are issued during the first address part, Ax. The Address Mapping in Multiplexed Address Mode table shows the addresses needed for both the first and second rising clock edges (Ax and Ay, respectively).

After MR0[9] is set HIGH, READ, WRITE, and MRS commands follow the format described in the Command Description in Multiplexed Address Mode figure. Refer to Multiplexed Address Mode for further information on operation with multiplexed addressing.

Mode Register 1 (MR1)

Figure 32: MR1 Definition for Non-Multiplexed Address Mode

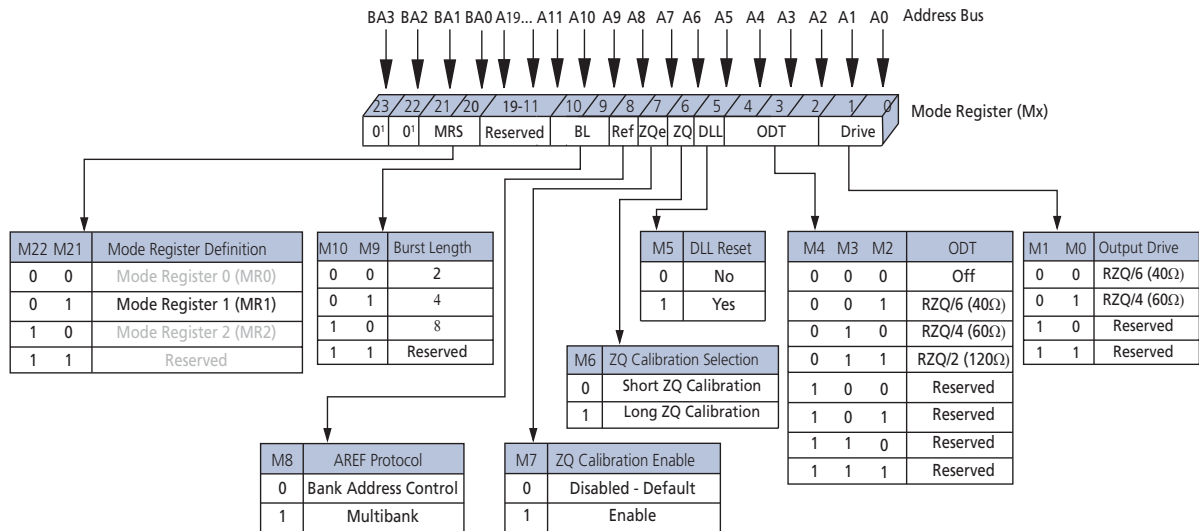

- Notes:
1. BA2, BA3, and all address balls corresponding to reserved bits must be held LOW during the MRS command.
 2. BL8 not available in x36.

Output Drive Impedance

The RLDRAM 3 uses programmable impedance output buffers, which enable the user to match the driver impedance to the system. MR1[0] and MR1[1] are used to select 40Ω or 60Ω output impedance, but the device powers up with an output impedance of 40Ω. The drivers have symmetrical output impedance. To calibrate the impedance a 240Ω ±1% external precision resistor (RZQ) is connected between the ZQ ball and V_{SSQ}.

The output impedance is calibrated during initialization through the ZQCL mode register setting. Subsequent periodic calibrations (ZQCS) may be performed to compensate for shifts in output impedance due to changes in temperature and voltage. More detailed information on calibration can be found in the ZQ Calibration section.

DQ On-Die Termination (ODT)

MR1[4:2] are used to select the value of the on-die termination (ODT) for the DQ, DKx and DM balls. When enabled, ODT terminates these balls to $V_{DDQ}/2$. The RLD RAM 3 device supports 40Ω, 60Ω, or 120Ω ODT. The ODT function is dynamically switched off when a DQ begins to drive after a READ command has been issued. Similarly, ODT is designed to switch on at the DQs after the RLD RAM has issued the last piece of data. The DM and DKx balls are always terminated after ODT is enabled.

DLL Reset

Programming MR1[5] to 1 activates the DLL RESET function. MR1[5] is self-clearing, meaning it returns to a value of 0 after the DLL RESET function has been initiated.

Whenever the DLL RESET function is initiated, CK/CK# must be held stable for 512 clock cycles before a READ command can be issued. This is to allow time for the internal clock to be synchronized with the external clock. Failing to wait for synchronization to occur may cause output timing specifications, such as t_{CKQK} , to be invalid.

ZQ Calibration

The ZQ CALIBRATION mode register command is used to calibrate the DRAM output drivers (R_{ON}) and ODT values (R_{TT}) over process, voltage, and temperature, provided a dedicated 240Ω ($\pm 1\%$) external resistor is connected from the DRAM's RZQ ball to V_{SSQ} . Bit MR1[6] selects between ZQ calibration long (ZQCL) and ZQ calibration short (ZQCS), each of which are described in detail below. When bit MR1[7] is set HIGH, it enables the calibration sequence. Upon completion of the ZQ calibration sequence, MR1[7] automatically resets LOW.

The RLD RAM 3 needs a longer time to calibrate R_{ON} and ODT at power-up initialization and a relatively shorter time to perform periodic calibrations. An example of ZQ calibration timing is shown below.

All banks must have t_{RC} met before ZQCL or ZQCS mode register settings can be issued to the DRAM. No other activities (other than loading another ZQCL or ZQCS mode register setting may be issued to another DRAM) can be performed on the DRAM channel by the controller for the duration of t_{ZQinit} or t_{ZQoper} . The quiet time on the DRAM channel helps accurately calibrate R_{ON} and ODT. After DRAM calibration is achieved, the DRAM will disable the ZQ ball's current consumption path to reduce power.

ZQ CALIBRATION mode register settings can be loaded in parallel to DLL reset and locking time.

In systems that share the ZQ resistor between devices, the controller must not allow overlap of t_{ZQinit} , t_{ZQoper} , or t_{ZQcs} between devices.

Figure 33: ZQ Calibration Timing (ZQCL and ZQCS)

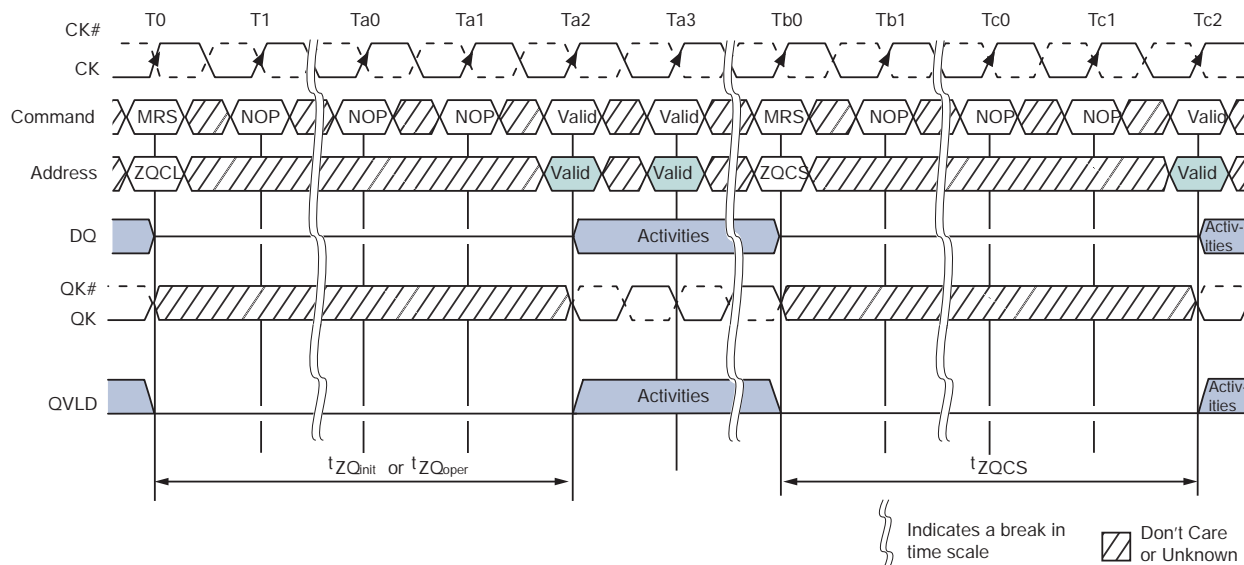

- Notes:
1. All devices connected to the DQ bus should be held High-Z during calibration.
 2. The state of QK and QK# are unknown during ZQ calibration.
 3. t^{MRSC} after loading the MR1 settings, QVLD output drive strength will be at the value selected or lower (lower resistance) until ZQ calibration is complete.

ZQ Calibration Long

The ZQ calibration long (ZQCL) mode register setting is used to perform the initial calibration during a power-up initialization and reset sequence. It may be loaded at any time by the controller depending on the system environment. ZQCL triggers the calibration engine inside the DRAM. After calibration is achieved, the calibrated values are transferred from the calibration engine to the DRAM I/O, which are reflected as updated R_{ON} and ODT values.

The DRAM is allowed a timing window defined by either t^{ZQinit} or t^{ZQoper} to perform the full calibration and transfer of values. When ZQCL is issued during the initialization sequence, the timing parameter t^{ZQinit} must be satisfied. When initialization is complete, subsequent loading of the ZQCL mode register setting requires the timing parameter t^{ZQoper} to be satisfied.

ZQ Calibration Short

The ZQ calibration short (ZQCS) mode register setting is used to perform periodic calibrations to account for small voltage and temperature variations. The shorter timing window is provided to perform the reduced calibration and transfer of values as defined by timing parameter t^{ZQCS} . ZQCS can effectively correct a minimum of 0.5% R_{ON} and R_{TT} impedance error within 64 clock cycles, assuming the maximum sensitivities specified in the ODT Temperature and Voltage Sensitivity and the Output Driver Voltage and Temperature Sensitivity tables.



AUTO REFRESH Protocol

The AUTO REFRESH (AREF) protocol is selected with bit MR1[8]. There are two ways in which AREF commands can be issued to the RLD RAM. Depending upon how bit MR1[8] is programmed, the memory controller can issue either bank address-controlled or multibank AREF commands. Bank address-controlled AREF uses the BA[3:0] inputs to refresh a single bank per command. Multibank AREF is enabled by setting bit MR1[8] HIGH during an MRS command. This refresh protocol enables the simultaneous refreshing of a row in up to four banks. In this method, the address pins A[15:0] represent banks 0–15, respectively. More information on both AREF protocols can be found in AUTO REFRESH Command.

Burst Length (BL)

Burst length is defined by MR1[9] and MR1[10]. Read and write accesses to the RLD RAM are burst-oriented, with the burst length being programmable to 2, 4, or 8. Figure 34 shows the different burst lengths with respect to a READ command. Changes in the burst length affect the width of the address bus (see the following table for details).

The data written by the prior burst length is not guaranteed to be accurate when the burst length of the device is changed.

Table 43: Address Widths of Different Burst Lengths

Burst Length	Configuration	
	x18	x36
2	A[19:0]	A[18:0]
4	A[18:0]	A[17:0]
8	A[17:0]	NA

Figure 34: Read Burst Lengths

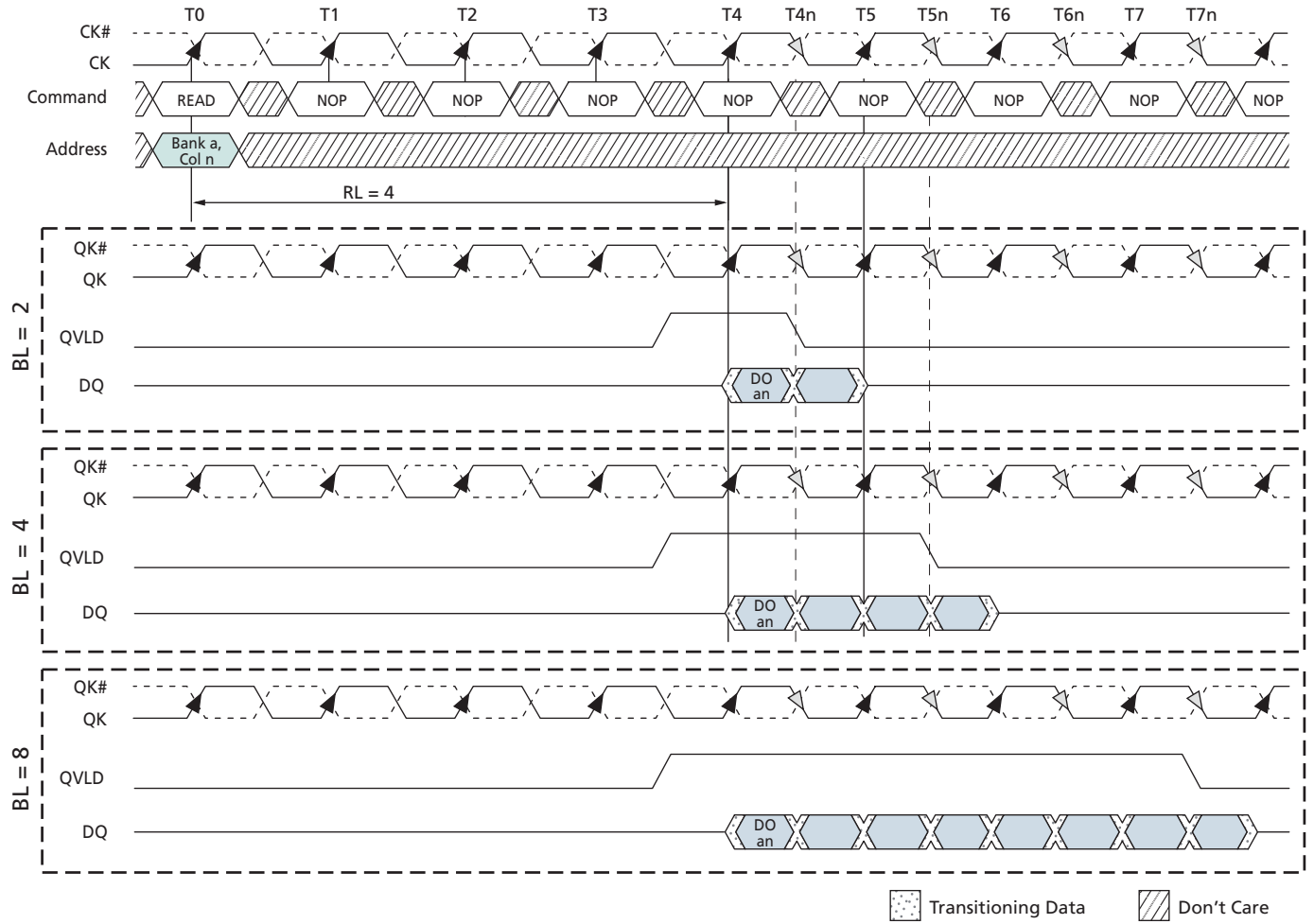

Note: 1. DO an = data-out from bank a and address an.



Mode Register 2 (MR2)

Figure 35: MR2 Definition for Non-Multiplexed Address Mode

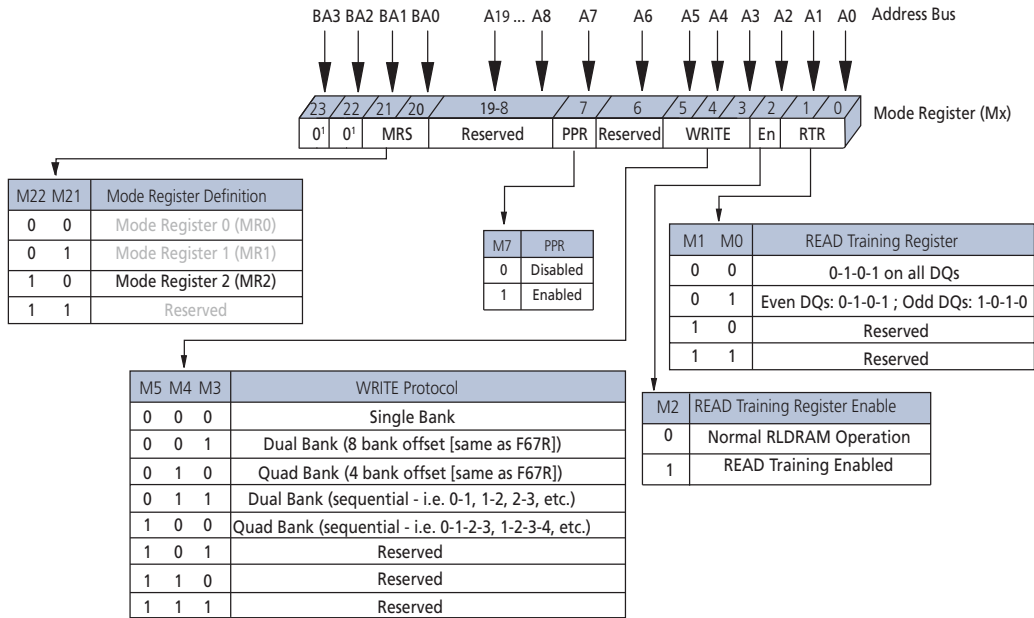

Note: 1. BA2, BA3, and all address balls corresponding to reserved bits must be held LOW during the MRS command.

READ Training Register (RTR)

The READ training register (RTR) is controlled through MR2[2:0]. It is used to output a predefined bit sequence on the output balls to aid in system timing calibration. MR2[2] is the master bit that enables or disables access to the READ training register, and MR2[1:0] determine which predefined pattern for system calibration is selected. If MR2[2] is set to 0, the RTR is disabled, and the DRAM operates in normal mode. When MR2[2] is set to 1, the DRAM no longer outputs normal read data, but a predefined pattern that is defined by MR2[1:0].

Prior to enabling the RTR, all banks must be in the idle state (t_{RC} met). When the RTR is enabled, all subsequent READ commands will output four bits of a predefined sequence from the RTR on all DQs. The READ latency during RTR is defined with the Data Latency bits in MR0. To loop on the predefined pattern when the RTR is enabled, successive READ commands must be issued and satisfy t_{RTRS} . Address balls A[19:0] are considered "Don't Care" during RTR READ commands. Bank address bits BA[3:0] must access Bank 0 with each RTR READ command. t_{RC} does not need to be met in between RTR READ commands to Bank 0. When the RTR is enabled, only READ commands are allowed. When the last RTR READ burst has completed and t_{RTR} has been satisfied, an MRS command can be issued to exit the RTR. Standard RLD RAM 3 operation may then start after t_{MRSC} has been met. The RESET function is supported when the RTR is enabled.

If MR2[1:0] is set to 00 a 0-1-0-1 pattern will be output on all DQs with each RTR READ command. If MR2[1:0] is set to 01, a 0-1-0-1 pattern will output on all even DQs and the opposite pattern, a 1-0-1-0, will output on all odd DQs with each RTR READ command.

WRITE Protocol

Single or multibank WRITE operation is programmed with bits MR2[4:3]. The purpose of multibank WRITE operation is to reduce the effective t_{RC} during READ commands. When dual- or quad-bank WRITE protocol is selected, identical data is written to two or four banks, respectively. With the same data stored in multiple banks on the RLD RAM, the memory controller can select the appropriate bank to READ the data from and minimize t_{RC} delay. Detailed information on the multibank WRITE protocol can be found in Multibank WRITE.

WRITE Command

Write accesses are initiated with a WRITE command. The address needs to be provided concurrent with the WRITE command.

During WRITE commands, data will be registered at both edges of DK, according to the programmed burst length (BL). The RLD RAM operates with a WRITE latency (WL) determined by the data latency bits within MR0. The first valid data is registered at the first rising DK edge WL cycles after the WRITE command.

Any WRITE burst may be followed by a subsequent READ command (assuming t_{RC} is met). Depending on the amount of input timing skew, an additional NOP command might be necessary between WRITE and READ commands to avoid external data bus contention.

Figure 36: READ Training Function - Back-to-Back Readout

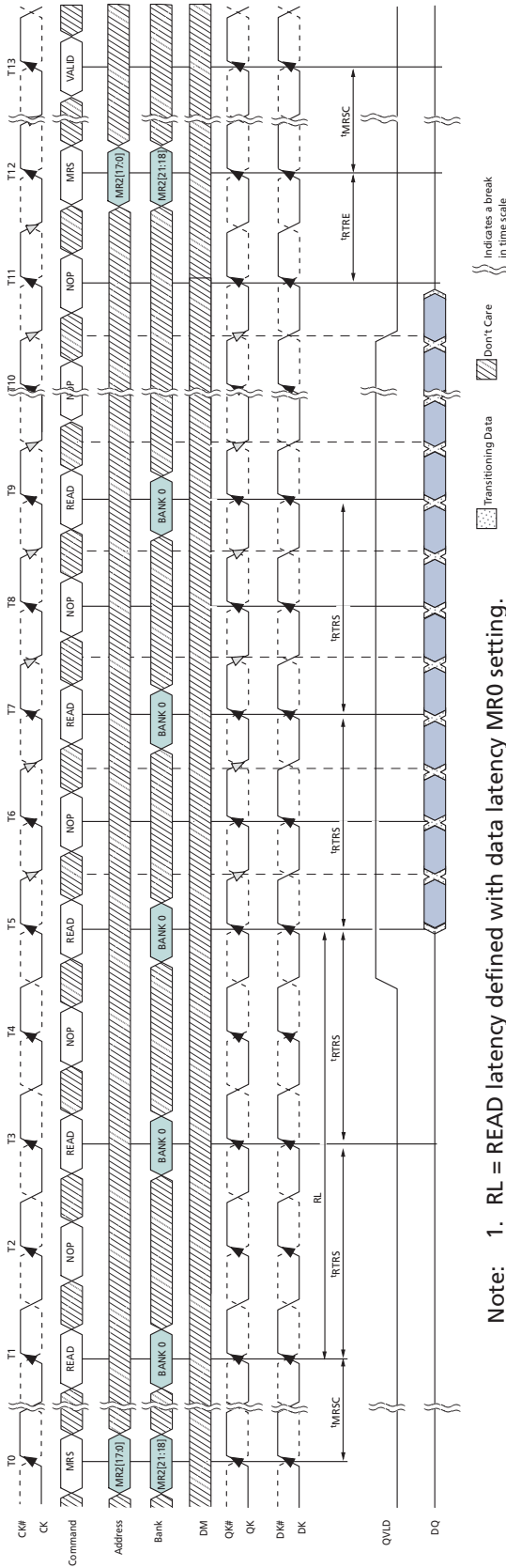

Note: 1. RL = READ latency defined with data latency MR0 setting.

Setup and hold times for incoming DQ relative to the DK edges are specified as t_{DS} and t_{DH} . The input data is masked if the corresponding DM signal is HIGH.

Figure 37: WRITE Command

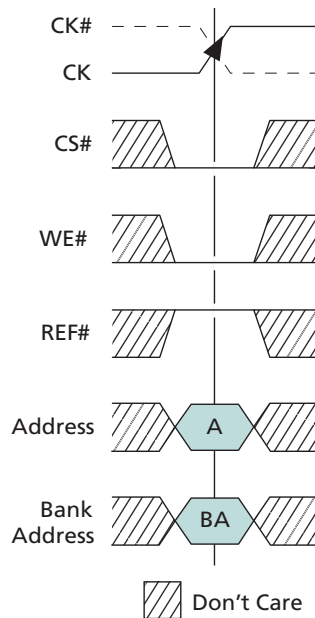

Multibank WRITE

All the information provided above in the WRITE section is applicable to a multibank WRITE operation as well. Either two or four banks can be simultaneously written to when the appropriate MR2[4:3] mode register bits are selected.

If a dual-bank WRITE has been selected through the mode register, both banks x and $x+8$ will be written to simultaneously with identical data provided during the WRITE command. For example, when a dual-bank WRITE has been loaded and the bank address for Bank 1 has been provided during the WRITE command, Bank 9 will also be written to at the same time. When a dual-bank WRITE command is issued, only bank address bits BA[2:0] are valid and BA3 is considered a “Don’t Care.”

The same methodology is used if the quad-bank WRITE has been selected through the mode register. Under these conditions, when a WRITE command is issued to Bank x , the data provided on the DQs will be issued to banks x , $x+4$, $x+8$, and $x+12$. When a quad-bank WRITE command is issued, only bank address bits BA[1:0] are valid and BA[3:2] are considered “Don’t Care.”

The timing parameter t_{SAW} must be adhered to when operating with multibank WRITE commands. This parameter limits the number of active banks at 16 within an 8ns window. The t_{MMD} specification must also be followed if the quad-bank WRITE is being used. This specification requires two clock cycles between any bank command (READ, WRITE, or AREF) to a quad-bank WRITE or a quad-bank WRITE to any bank command. The data bus efficiency is not compromised if BL4 or BL8 is being utilized.



Post Package Repair – PPR

This section provides guidance on the implementation of post package repair (PPR).

PPR supports 1 row repair per half bank.

The controller provides the failing bank and address in the PPR sequence to the DRAM to perform the row repair.

PPR Row Repair Sequence

During the RLD RAM3 initialization sequence, RESET# must be LOW.

All banks must be idle before and during the PPR process.

All PPR DRAM timings must be followed .

All other commands except those listed in the following sequence are illegal.

1. Issue MR2 7[1] command to enter PPR mode enable
2. Issue the following 4 MR0 qualifying commands:
 - a. MR0 14[0], 13[1], 11:10[1], 9:8[0],7:0[1]
 - b. MR0 14[0], 13[1], 11[0], 10:0[1]
 - c. MR0 14[0], 13[1], 11[1], 10:[0], 9:0[1]
 - d. MR0 14[0], 13[1], 11:10[0], 9:0[1]
3. WRITE command executes PPR.

NOTE: Program time ($t_{PGM} = 1000ms$):

 - a. Issue WR command with failing bank address (BA) and address.
 - b. At $t_{WL} DQ[8:0]$ must be LOW at first rising DK edge.
4. Issue MR2[7:0] command to exit PPR.
 - a. Wait t_{PGMSPT} time (50 μs) for PPR mode exit to complete.

The entire sequence may be repeated if more than one repair is needed.

Table 44: RLD RAM3 PPR Timing Parameters

Parameter	Symbol	Min	Max	Unit
PPR programming time	t_{PGM}	1000	–	ms
PPR exit time	t_{PGMSPT}	50	–	μs

Figure 38: Entry, Repair, and Exit Timing Diagram

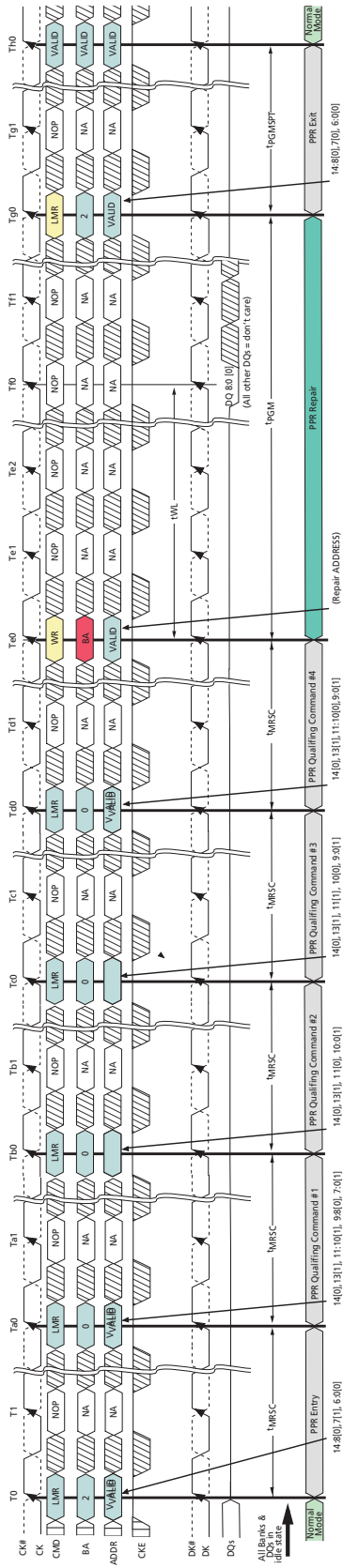

READ Command

Read accesses are initiated with a READ command (see the figure below). Addresses are provided with the READ command.

During READ bursts, the memory device drives the read data so it is edge-aligned with the QK signals. After a programmable READ latency, data is available at the outputs. One half clock cycle prior to valid data on the read bus, the data valid signal(s), QVLD, transitions from LOW to HIGH. QVLD is also edge-aligned with the QK signals.

The skew between QK and the crossing point of CK is specified as t_{CKQK} . t_{QKQx} is the skew between a QK pair and the last valid data edge generated at the DQ signals in the associated byte group, such as DQ[7:0] and QK0. t_{QKQx} is derived at each QK clock edge and is not cumulative over time. For the x36 device, the t_{QKQ02} and t_{QKQ13} specifications define the relationship between the DQs and QK signals within specific data word groupings. t_{QKQ02} defines the skew between QK0 and DQ[26:18] and between QK2 and DQ[8:0]. t_{QKQ13} defines the skew between QK1 and DQ[35:17] and between QK3 and DQ[17:9].

After completion of a burst, assuming no other commands have been initiated, output data (DQ) will go High-Z. The QVLD signal transitions LOW on the last bit of the READ burst. The QK clocks are free-running and will continue to cycle after the read burst is complete. Back-to-back READ commands are possible, producing a continuous flow of output data.

Any READ burst may be followed by a subsequent WRITE command. Some systems having long line lengths or severe skews may need an additional idle cycle inserted between READ and WRITE commands to prevent data bus contention.

Figure 39: READ Command

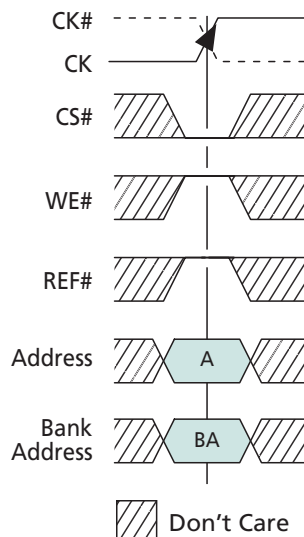

AUTO REFRESH Command

The RLD RAM 3 device uses two unique AUTO REFRESH (AREF) command protocols, bank address-controlled AREF and multibank AREF. The desired protocol is selected by setting MR1[8] LOW (for bank address-controlled AREF) or HIGH (for multibank AREF) during an MRS command. Bank address-controlled AREF is identical to the method used in RLD RAM2 devices, whereby banks are refreshed independently. The value on bank addresses BA[3:0], issued concurrently with the AREF command, define which bank is to be refreshed. The array address is generated by an internal refresh counter, effectively making each address bit a "Don't Care" during the AREF command. The delay between the AREF command and a subsequent command to the same bank must be at least t_{RC} .

Figure 40: Bank Address-Controlled AUTO REFRESH Command

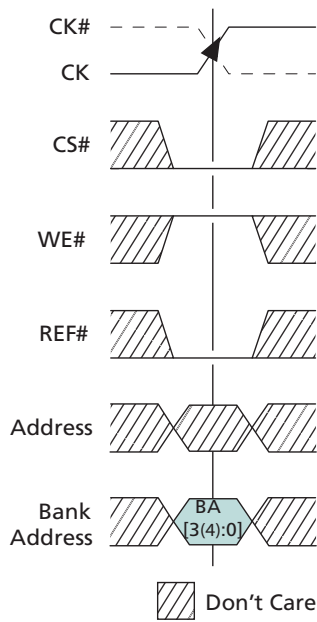

The multibank AREF protocol, enabled by setting bit MR1[8] HIGH during an MRS command, enables the simultaneous refresh of a row in up to four banks. In this method, address balls A[15:0] represent banks [15:0], respectively. The row addresses are generated by an internal refresh counter for each bank; therefore, the purpose of the address balls during an AREF command is only to identify the banks to be refreshed. The bank address balls BA[3:0] are considered "Don't Care" during a multibank AREF command.

A multibank AUTO REFRESH is performed for a given bank when its corresponding address ball is asserted HIGH during an AREF command. Any combination of up to four address balls can be asserted HIGH during the rising clock edge of an AREF command to simultaneously refresh a row in each corresponding bank. The delay between an AREF command and subsequent commands to the banks refreshed must be at least t_{RC} . Adherence to t_{SAW} must be followed when simultaneously refreshing multiple banks. If refreshing three or four banks with the multibank AREF command, t_{MMD} must be followed. This specification requires two clock cycles between any bank command (READ, WRITE, AREF) to the multibank AREF or the multibank AREF to any bank

command. Note that refreshing one or two banks with the multibank AREF command is not subject to the t_{MMD} specification.

The entire device must be refreshed every 64ms (t_{REF}). The RLD RAM device requires 128K cycles at an average periodic interval of 0.489 μ s MAX (64ms/[8K rows x 16 banks]).

Figure 41: Multibank AUTO REFRESH Command

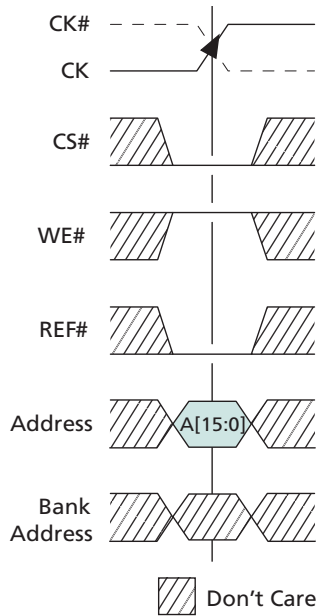



INITIALIZATION Operation

The RLD RAM 3 device must be powered up and initialized in a predefined manner. Operational procedures other than those specified may result in undefined operations or permanent damage to the device.

The following sequence is used for power-up:

1. Apply power (V_{EXT} , V_{DD} , V_{DDQ}). Apply V_{DD} and V_{EXT} before, or at the same time as, V_{DDQ} . V_{DD} must not exceed V_{EXT} during power supply ramp. V_{EXT} , V_{DD} , V_{DDQ} must all ramp to their respective minimum DC levels within 200ms.
2. Ensure that $RESET\#$ is below $0.2 \times V_{DDQ}$ during power ramp to ensure the outputs remain disabled (High-Z) and ODT is off (R_{TT} is also High-Z). DQs, and QK signals will remain High-Z until MR0 command. All other inputs may be undefined during the power ramp.
3. After the power is stable, $RESET\#$ must be LOW for at least 200 μ s to begin the initialization process.
4. After 100 or more stable input clock cycles with NOP commands, bring $RESET\#$ HIGH.
5. After $RESET\#$ goes HIGH, a stable clock must be applied in conjunction with NOP commands and all Address pins (A[19:0] & BA[3:0]) to be held low for 10,000 cycles.
6. Load desired settings into MR0.
7. ^tMRSC after loading the MR0 settings, load operating parameters in MR1, including DLL Reset and Long ZQ Calibration.
8. After the DLL is reset and Long ZQ Calibration is enabled, the input clock must be stable for 512 clock cycles while NOPs are issued.
9. Load desired settings into MR2. If using the RTR, follow the procedure outlined in the READ Training Function – Back-to-Back Readout figure prior to entering normal operation.
10. The RLD RAM 3 is ready for normal operation.

Figure 42: Power-Up/Initialization Sequence

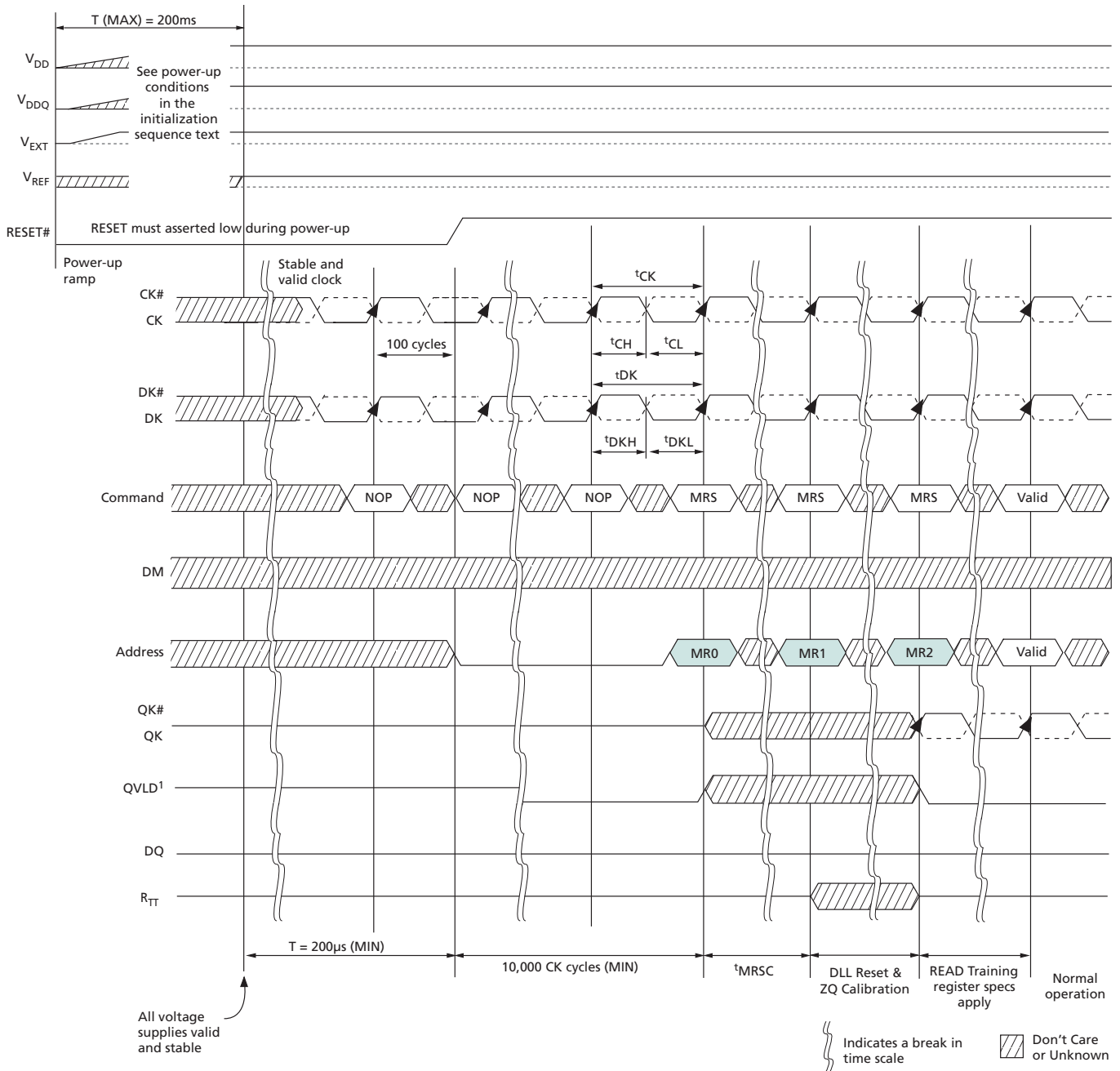

- Notes: 1. QVLD output drive status during power-up and initialization:
- QVLD will remain at High-Z while RESET# is LOW.
 - After RESET# goes HIGH, QVLD will transition LOW after approximately 20ns.
 - QVLD will then continue to drive LOW with 40Ω or lower until MR0 is enabled. After MR0 has been enabled, the state of QVLD becomes unknown.



- d. QVLD will meet the output drive strength specifications when the ZQ calibration is complete.
2. After MR2 has been issued, R_{TT} is either High-Z or enabled to the ODT value selected in MR1.

WRITE Operation

Figure43: WRITE Burst

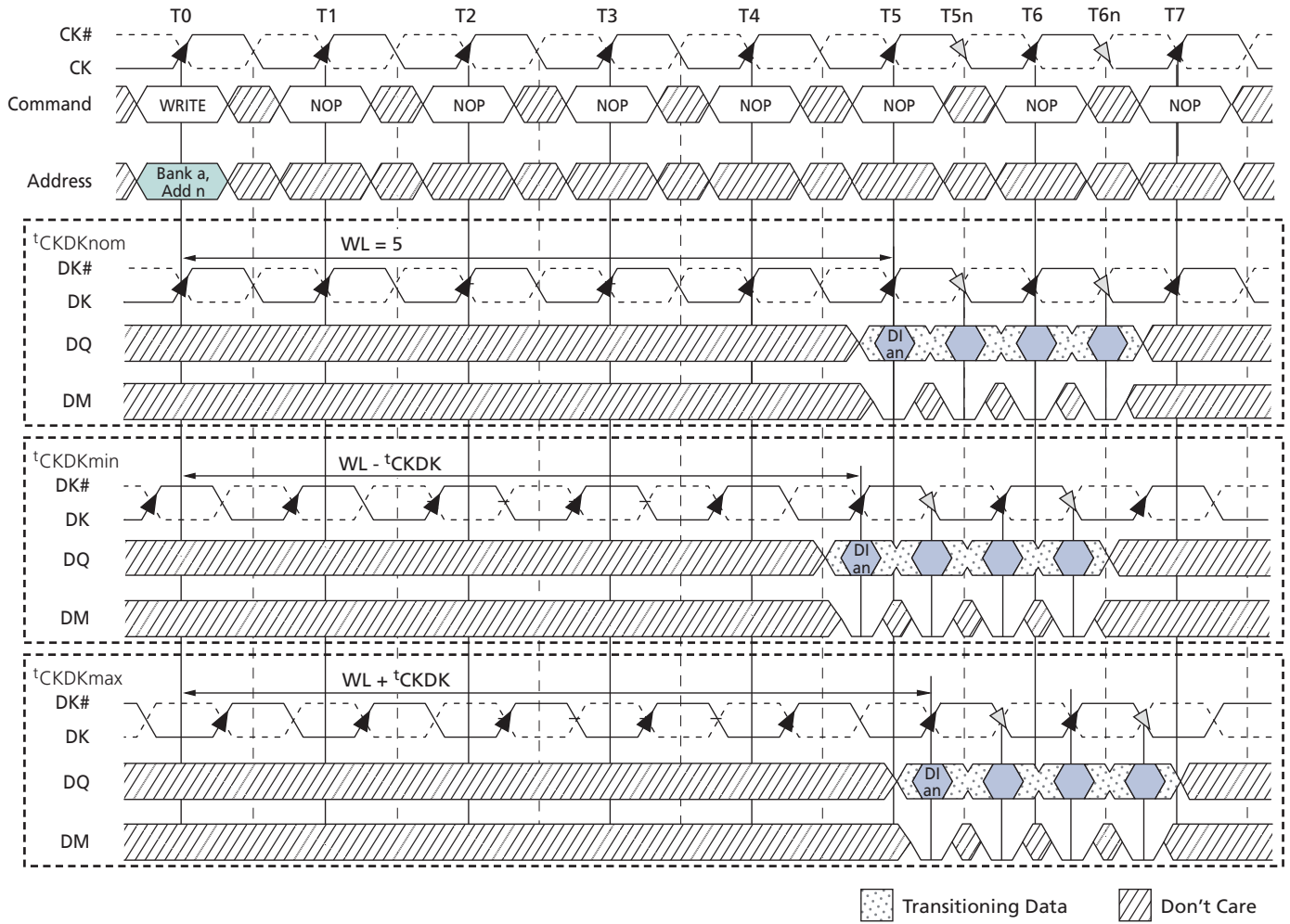

Note: 1. DI an = data-in for bank a and address n.

Figure 44: Consecutive WRITE Bursts



Note: 1. DI an (or bn or cn) = data-in for bank a (or b or c) and address n.

Figure 45: WRITE-to-READ

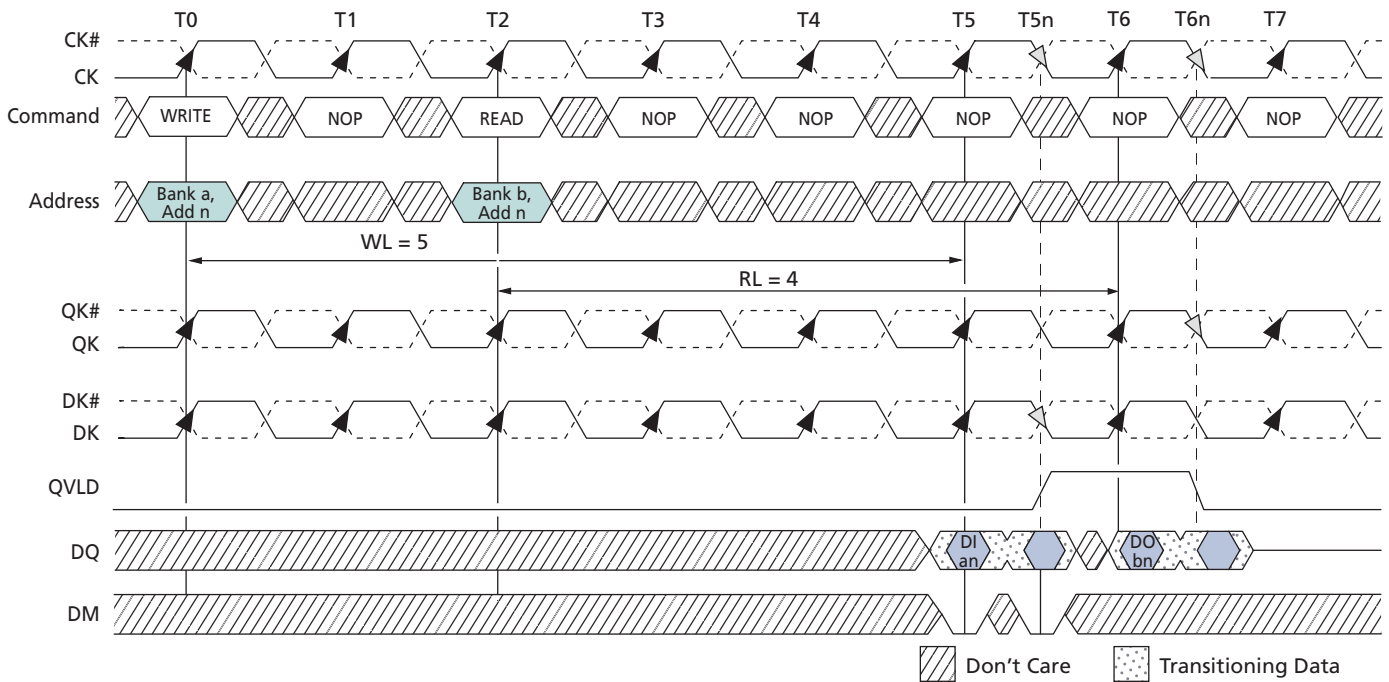

Notes: 1. DI an = data-in for bank a and address n.
2. DO bn = data-out from bank b and address n.

Figure 46: WRITE - DM Operation

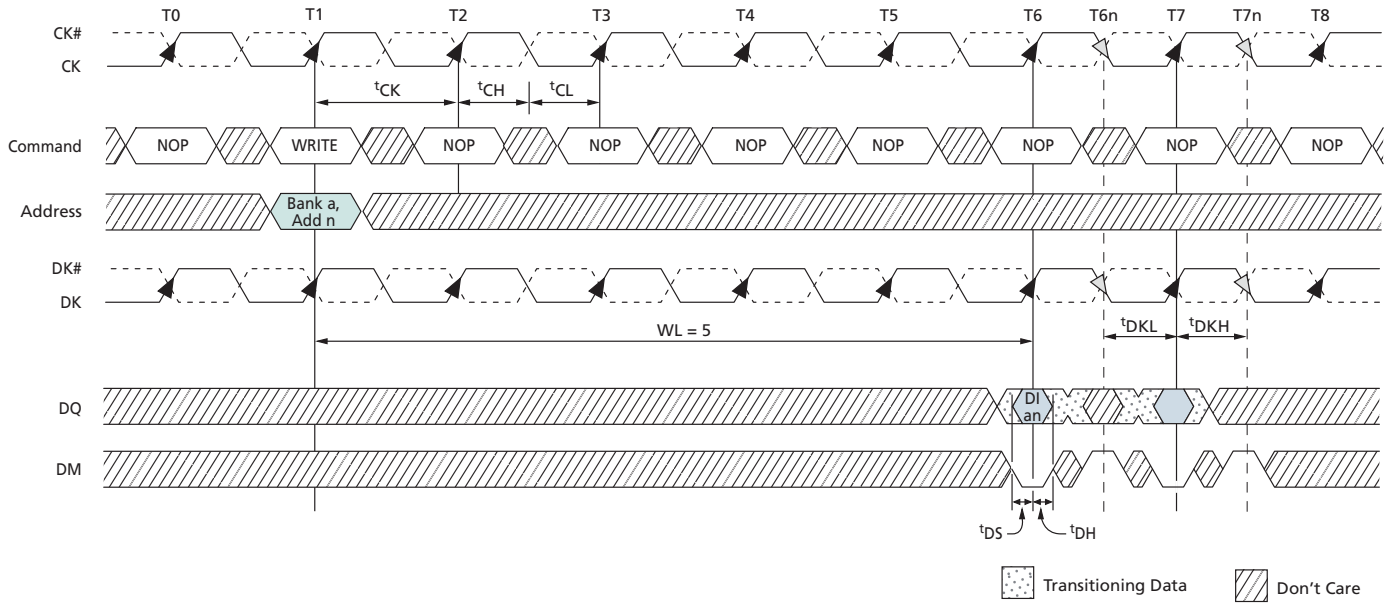

Note: 1. DI an = data-in for bank a and address n.

Figure 47: Consecutive Quad Bank WRITE Bursts

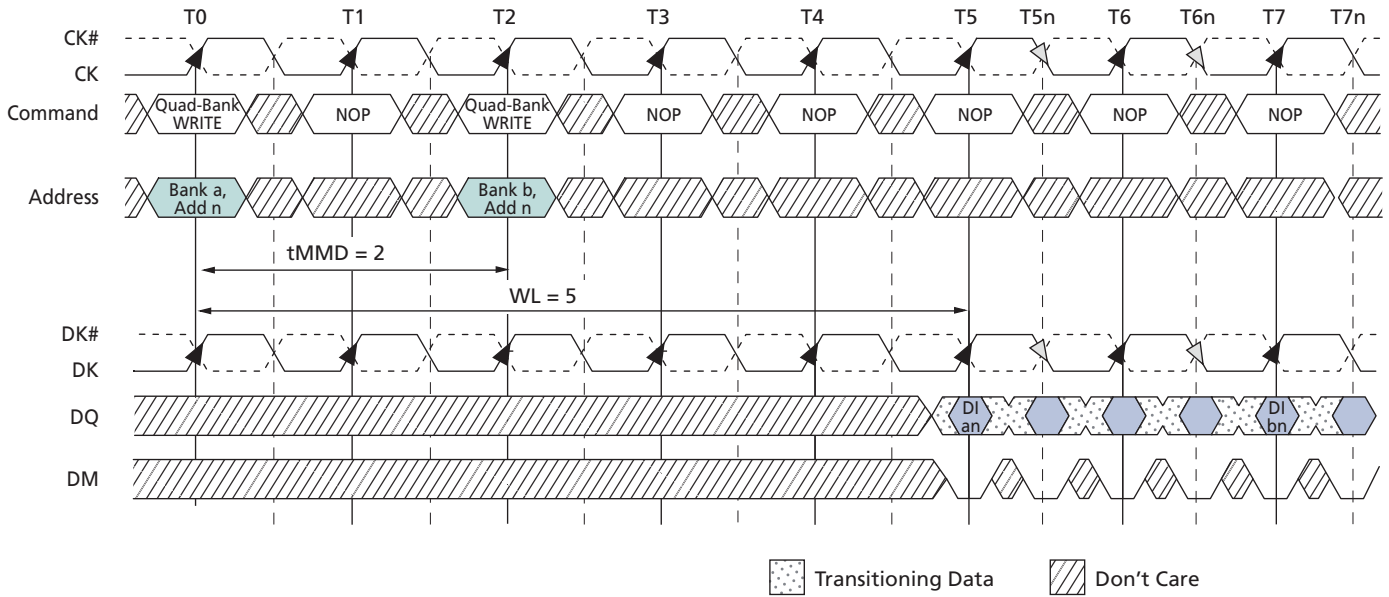

- Notes: 1. DI *an* = data-in for bank *a*, *a*+4, *a*+8, and *a*+12 and address *n*.
2. DI *bn* = data-in for bank *b*, *b*+4, *b*+8, and *b*+12 and address *n*.

Figure 48: Interleaved READ and Quad Bank WRITE Bursts

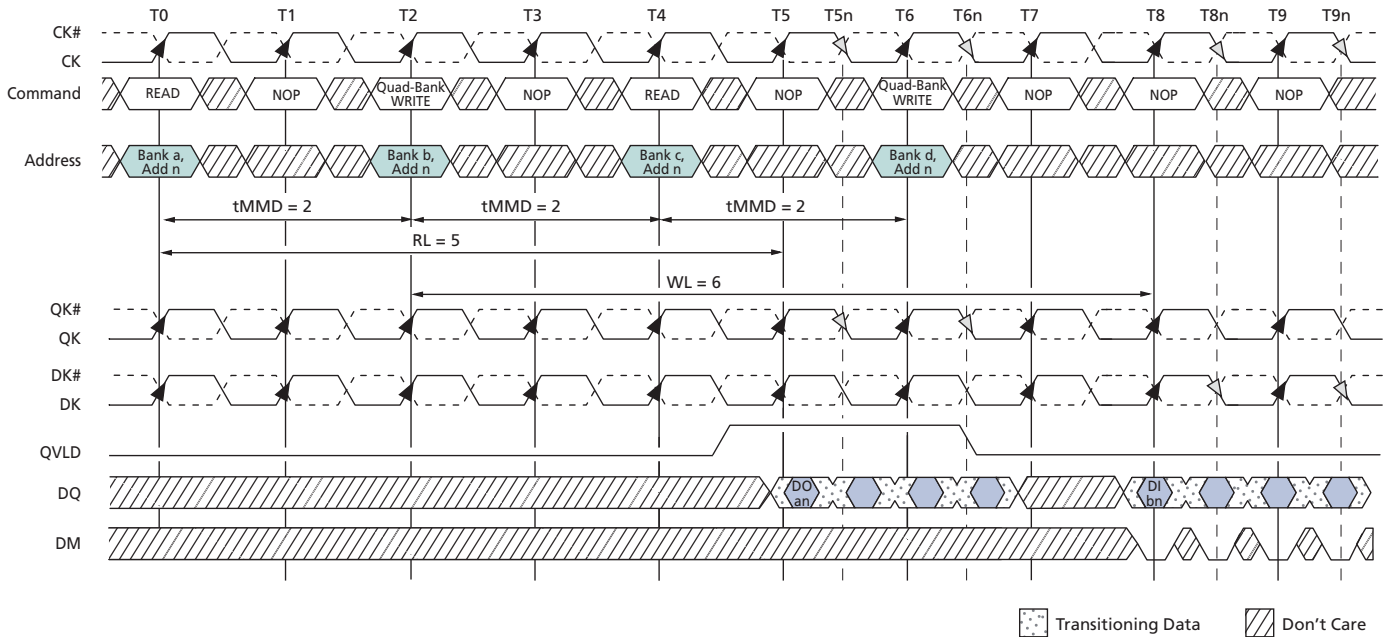

- Notes: 1. DO *an* = data-out for bank *a* and address *n*.
2. DI *bn* = data-in for bank *b*, *b*+4, *b*+8, and *b*+12 and address *n*.

READ Operation

Figure 49: Basic READ Burst

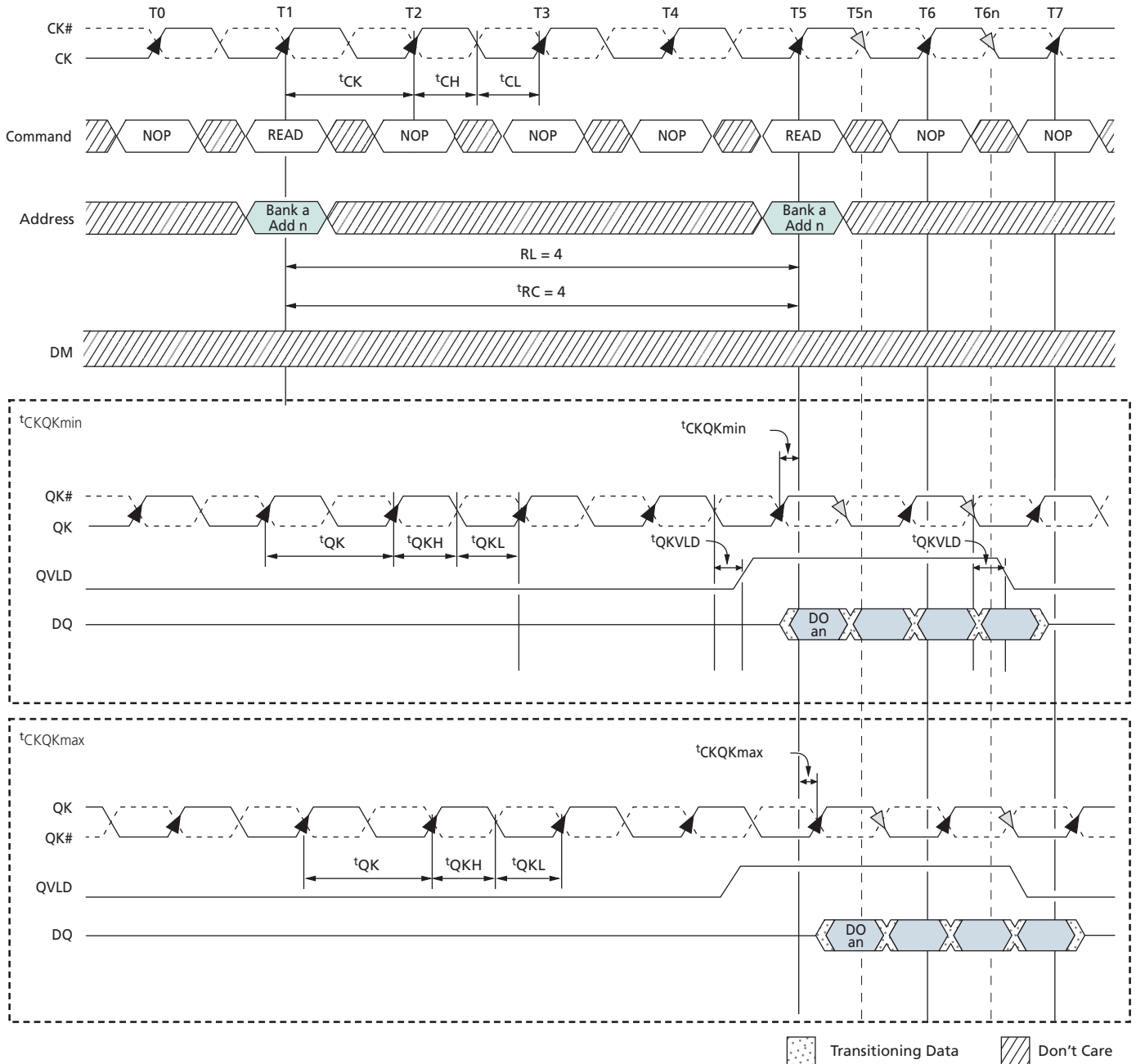

Note: 1. DO an = data-out from bank a and address an.

Figure 50: Consecutive READ Bursts (BL = 2)

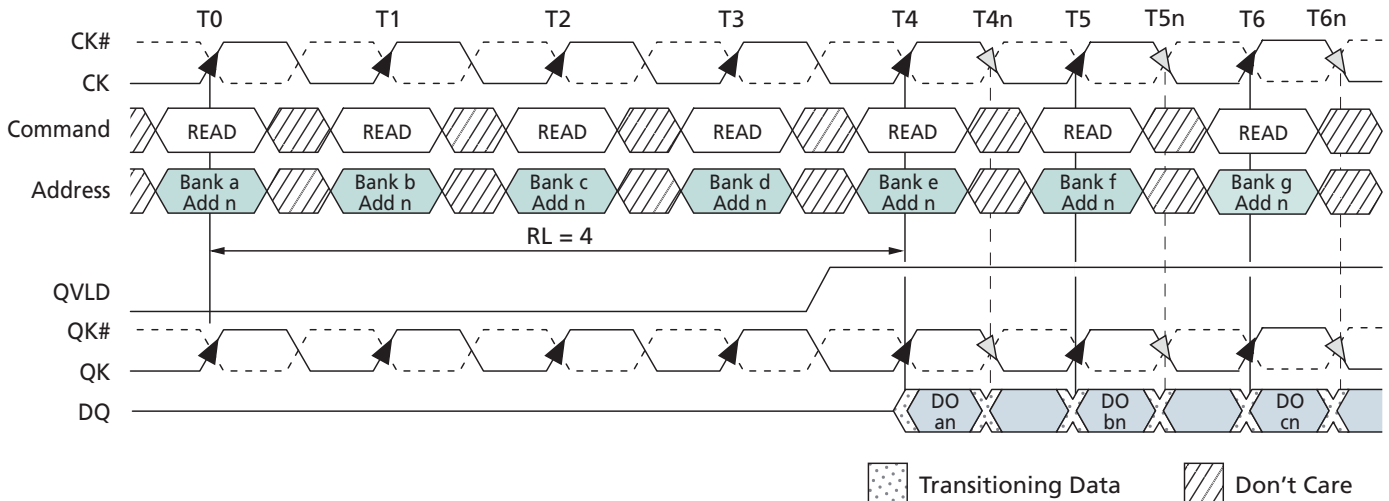

Note: 1. DO an (or bn, cn) = data-out from bank a (or bank b, c) and address n.

Figure 51: Consecutive READ Bursts (BL = 4)

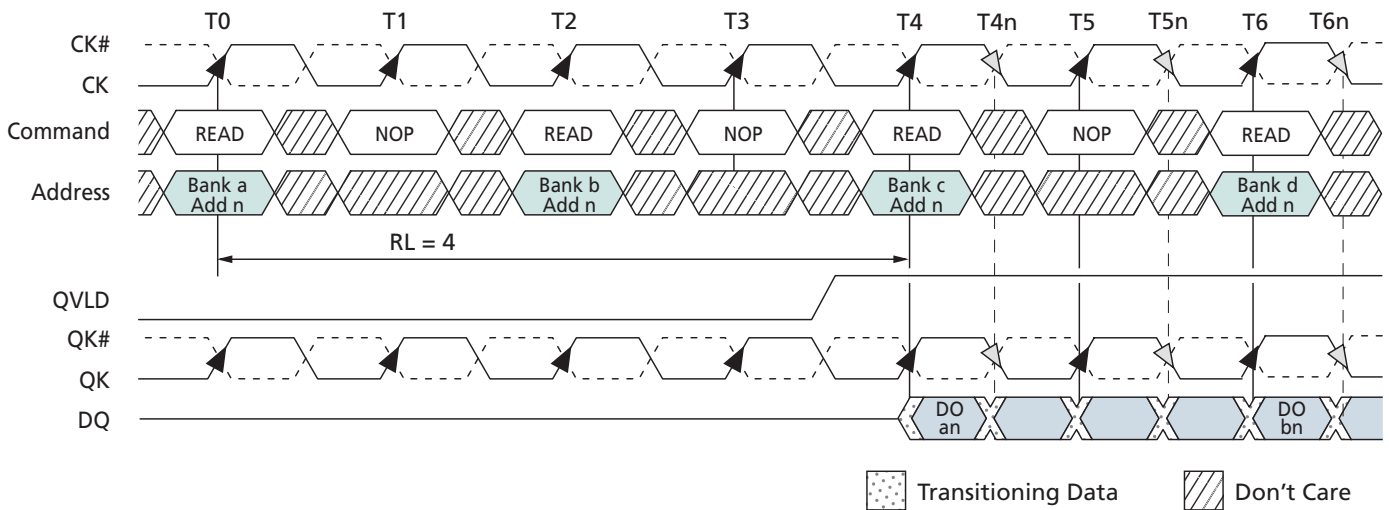

Note: 1. DO an (or bn) = data-out from bank a (or bank b) and address n.

AUTO REFRESH Operation

Figure 54: Bank Address-Controlled AUTO REFRESH Cycle

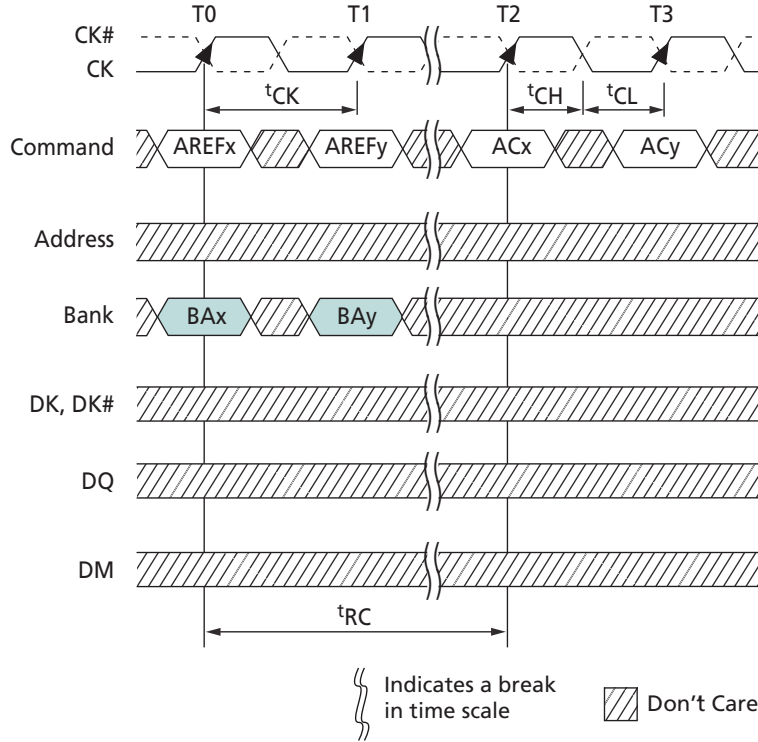

- Notes:
1. AREFx (or AREFy)= AUTO REFRESH command to bank x (or bank y).
 2. ACx = any command to bank x; ACy = any command to bank y.
 3. BAx = bank address to bank x; BAy = bank address to bank y.

Figure 55: Multibank AUTO REFRESH Cycle

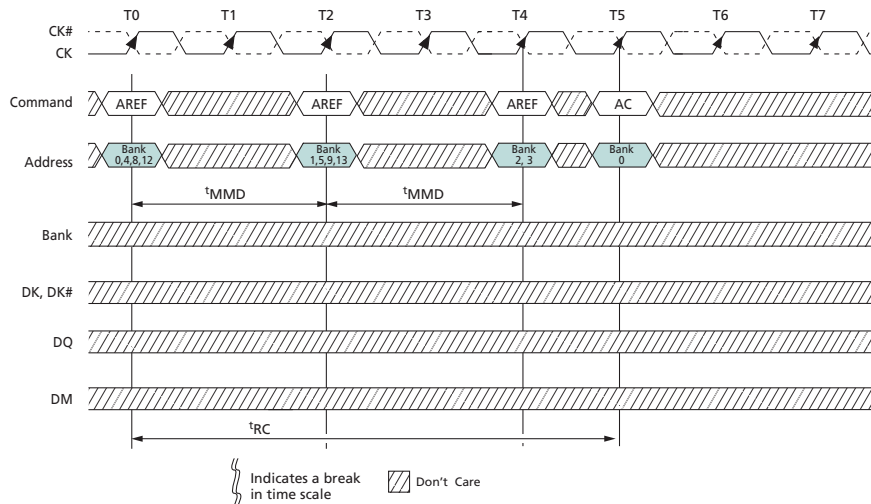
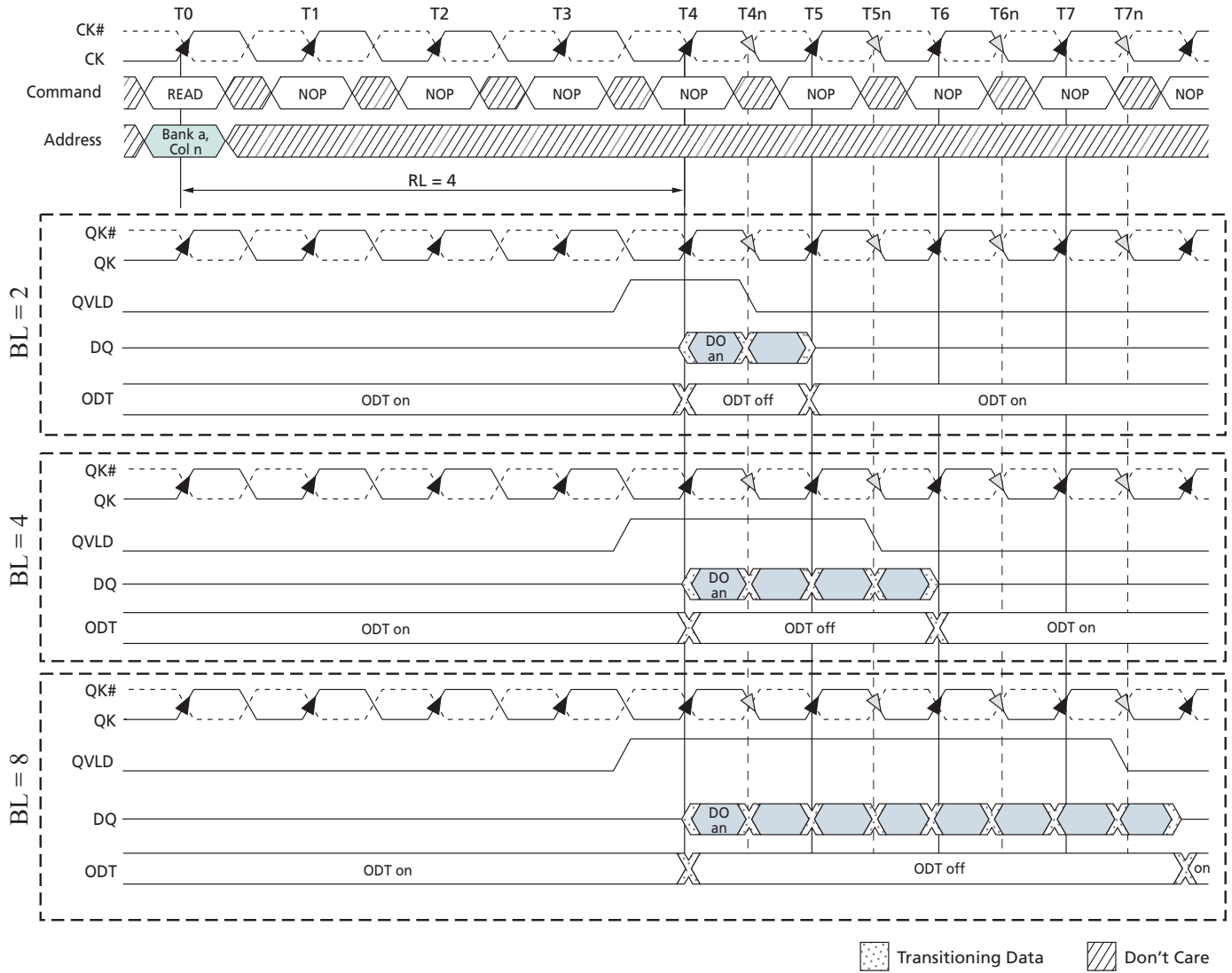
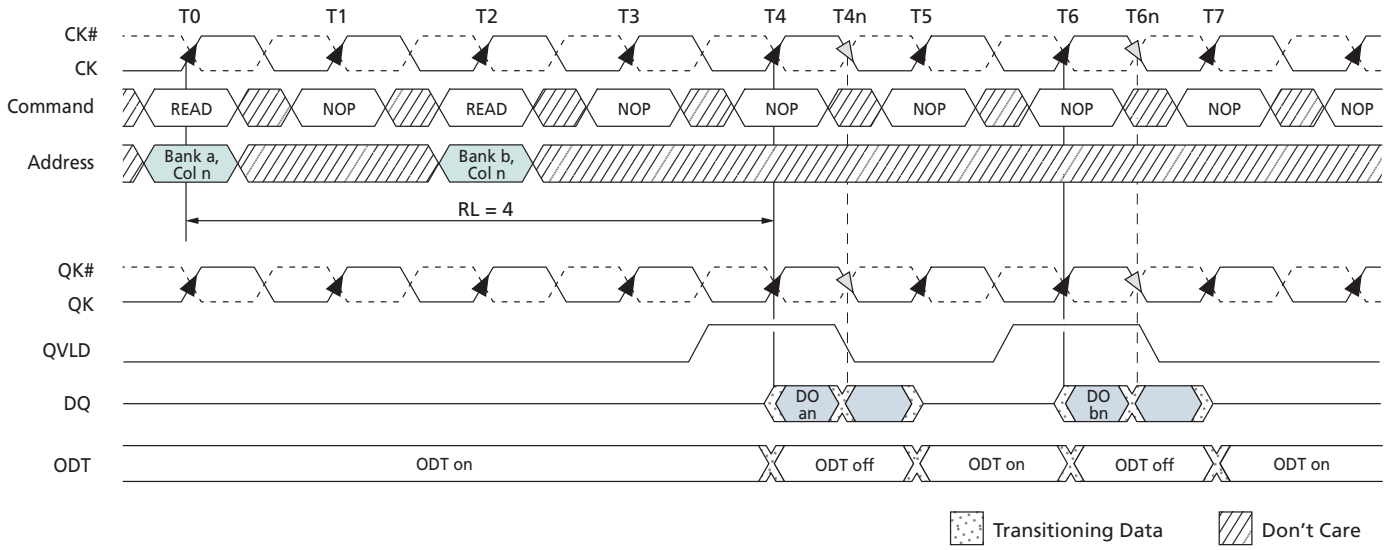

Figure 56: READ Burst with ODT



Note: 1. DO an = data out from bank a and address n.

Figure 57: READ-NOP-READ with ODT



Note: 1. DO_{an} (or DO_{bn}) = data-out from bank a (or bank b) and address n.

RESET Operation

The RESET signal (RESET#) is an asynchronous signal that triggers any time it drops LOW. There are no restrictions for when it can go LOW. After RESET# goes LOW, it must remain LOW for 100ns. During this time, the outputs are disabled, ODT (R_{TT}) turns off (High-Z), and the DRAM resets itself. Prior to RESET# going HIGH, at least 100 stable CK cycles with NOP commands must be given to the RLD RAM. After RESET# goes HIGH, the DRAM must be reinitialized as though a normal power-up was executed. All refresh counters on the DRAM are reset, and data stored in the DRAM is assumed unknown after RESET# has gone LOW.

Figure 58: RESET Sequence

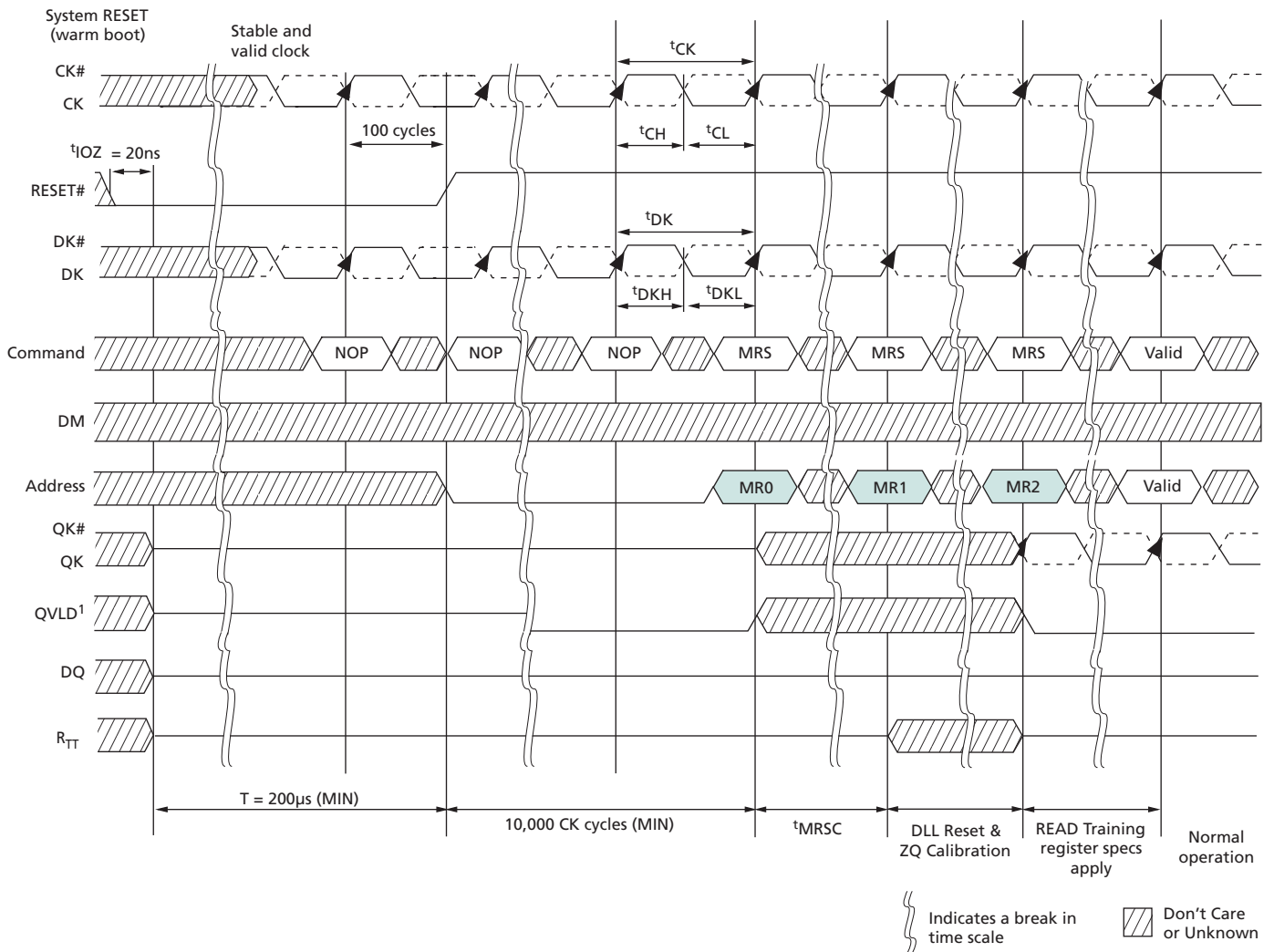



Clock Stop

If the clock is stopped or suspended after normal operation has begun, the RESET# pin must be asserted and the device reinitialized, before normal operation can continue. Refer to the RESET and INITIALIZATION Operation sections for more detail. All refresh counters on the DRAM are reset, and data stored in the DRAM is assumed unknown after RESET# has gone LOW.



Mirror Function

The mirror function ball (MF) is a DC input used to create mirrored ballouts for simple dual-loaded clamshell mounting. If the MF ball is tied LOW, the address and command balls are in their true layout. If the MF ball is tied HIGH, the address and command balls are mirrored around the central y-axis (column 7). The following table shows the ball assignments when the MF ball is tied HIGH for a x18 device. Compare that table to Table 1 to see how the address and command balls are mirrored. The same balls are mirrored on the x36 device.

Table 45: 32 Meg x 18 Ball Assignments with MF Ball Tied HIGH

	1	2	3	4	5	6	7	8	9	10	11	12	13
A		V _{SS}	V _{DD}	NF	V _{DDQ}	NF	V _{REF}	DQ7	V _{DDQ}	DQ8	V _{DD}	V _{SS}	RESET#
B	V _{EXT}	V _{SS}	NF	V _{SSQ}	NF	V _{DDQ}	DM0	V _{DDQ}	DQ5	V _{SSQ}	DQ6	V _{SS}	V _{EXT}
C	V _{DD}	NF	V _{DDQ}	NF	V _{SSQ}	NF	DK0#	DQ2	V _{SSQ}	DQ3	V _{DDQ}	DQ4	V _{DD}
D	A13	V _{SSQ}	NF	V _{DDQ}	NF	V _{SSQ}	DK0	V _{SSQ}	QK0	V _{DDQ}	DQ0	V _{SSQ}	A11
E	V _{SS}	CS#	V _{SSQ}	NF	V _{DDQ}	NF	MF	QK0#	V _{DDQ}	DQ1	V _{SSQ}	A0	V _{SS}
F	A9	A5	V _{DD}	A4	A3	REF#	ZQ	WE#	A1	A2	V _{DD}	NF	A7
G	V _{SS}	A18	A8	V _{SS}	BA0	V _{SS}	CK#	V _{SS}	BA1	V _{SS}	A6	A15	V _{SS}
H	A10	V _{DD}	A12	A17	V _{DD}	BA2	CK	BA3	V _{DD}	A16	A14	V _{DD}	A19
J	V _{DDQ}	NF	V _{SSQ}	NF	V _{DDQ}	NF	V _{SS}	QK1#	V _{DDQ}	DQ9	V _{SSQ}	QVLD	V _{DDQ}
K	NF	V _{SSQ}	NF	V _{DDQ}	NF	V _{SSQ}	DK1	V _{SSQ}	QK1	V _{DDQ}	DQ10	V _{SSQ}	DQ11
L	V _{DD}	NF	V _{DDQ}	NF	V _{SSQ}	NF	DK1#	DQ12	V _{SSQ}	DQ13	V _{DDQ}	DQ14	V _{DD}
M	V _{EXT}	V _{SS}	NF	V _{SSQ}	NF	V _{DDQ}	DM1	V _{DDQ}	DQ15	V _{SSQ}	DQ16	V _{SS}	V _{EXT}
N	V _{SS}	TCK	V _{DD}	TDO	V _{DDQ}	NF	V _{REF}	DQ17	V _{DDQ}	TDI	V _{DD}	TMS	V _{SS}

Multiplexed Address Mode

Figure 59: Command Description in Multiplexed Address Mode

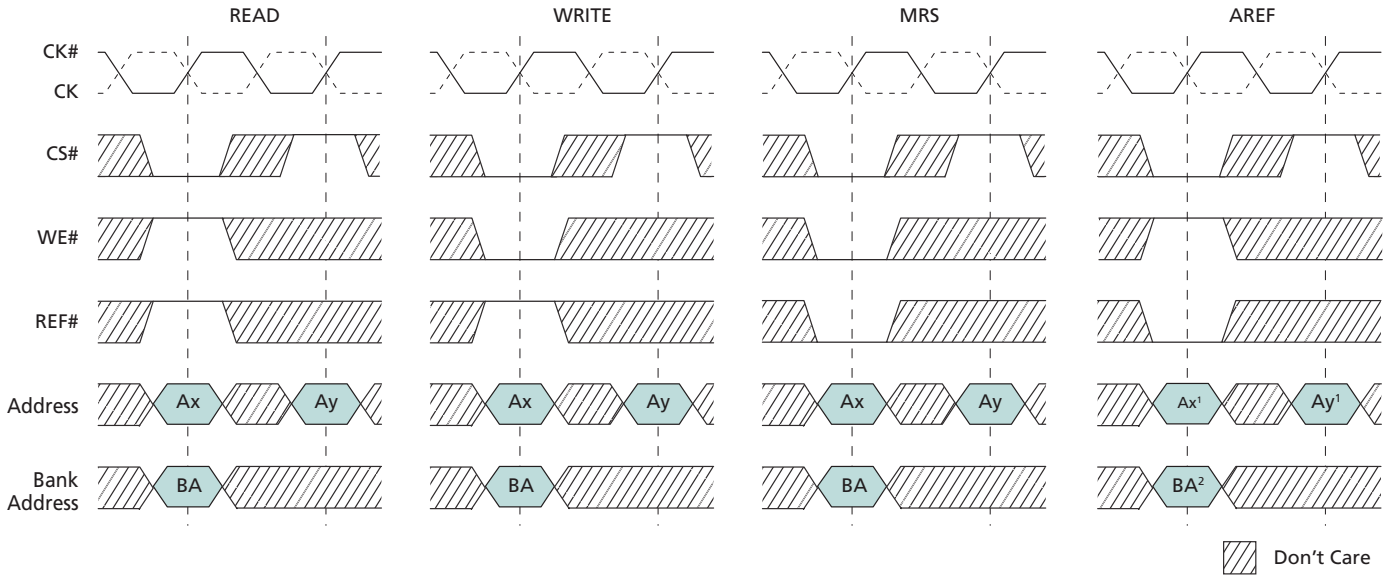

- Notes:
1. Addresses valid only during a multibank AUTO REFRESH command.
 2. Bank addresses valid only during a bank address-controlled AUTO REFRESH command.
 3. The minimum setup and hold times of the two address parts are defined as t_{IS} and t_{IH} .

Figure 60: Power-Up/Initialization Sequence in Multiplexed Address Mode

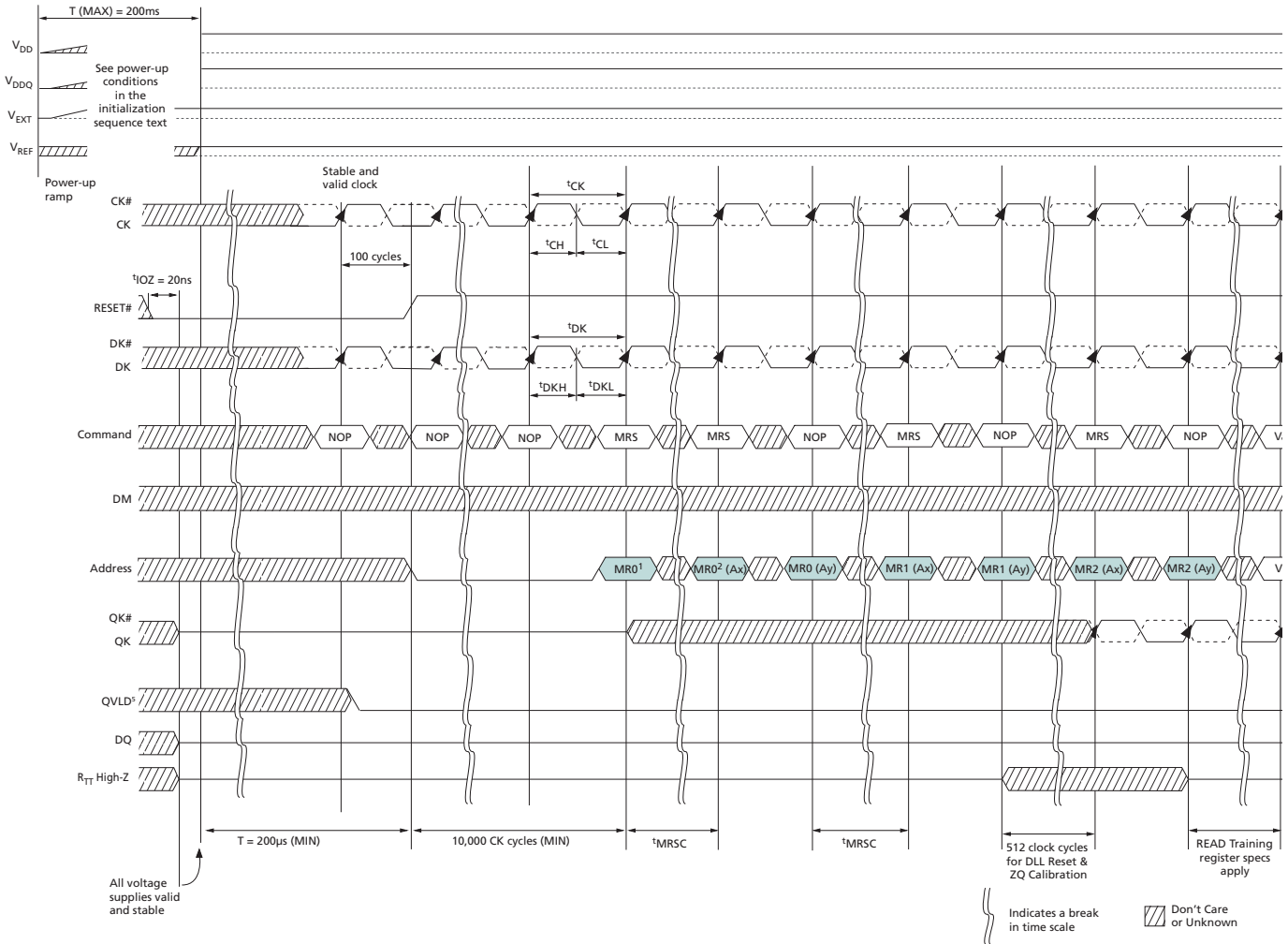

- Notes:
1. Set address bit MR0[9] HIGH. This enables the device to enter multiplexed address mode when in non-multiplexed mode operation. Multiplexed address mode can also be entered at a later time by issuing an MRS command with MR0[9] HIGH. After address bit MR0[9] is set HIGH, t_{MRSC} must be satisfied before the two-cycle multiplexed mode MRS command is issued.
 2. Address MR0[9] must be set HIGH. This and the following step set the desired MR0 setting after the RLD RAM device is in multiplexed address mode.
 3. MR1 (Ax), MR1 (Ay), MR2 (Ax), and MR2 (Ay) represent MR1 and MR2 settings in multiplexed address mode.
 4. The above sequence must be followed in order to power up the RLD RAM device in the multiplexed address mode.
 5. See QVLD output drive strength status during power up and initialization in non-multiplexed initialization operation section.
 6. After MR2 has been issued, R_{TT} is either High-Z or enabled to the ODT value selected in MR1.

Figure 61: MR0 Definition for Multiplexed Address Mode

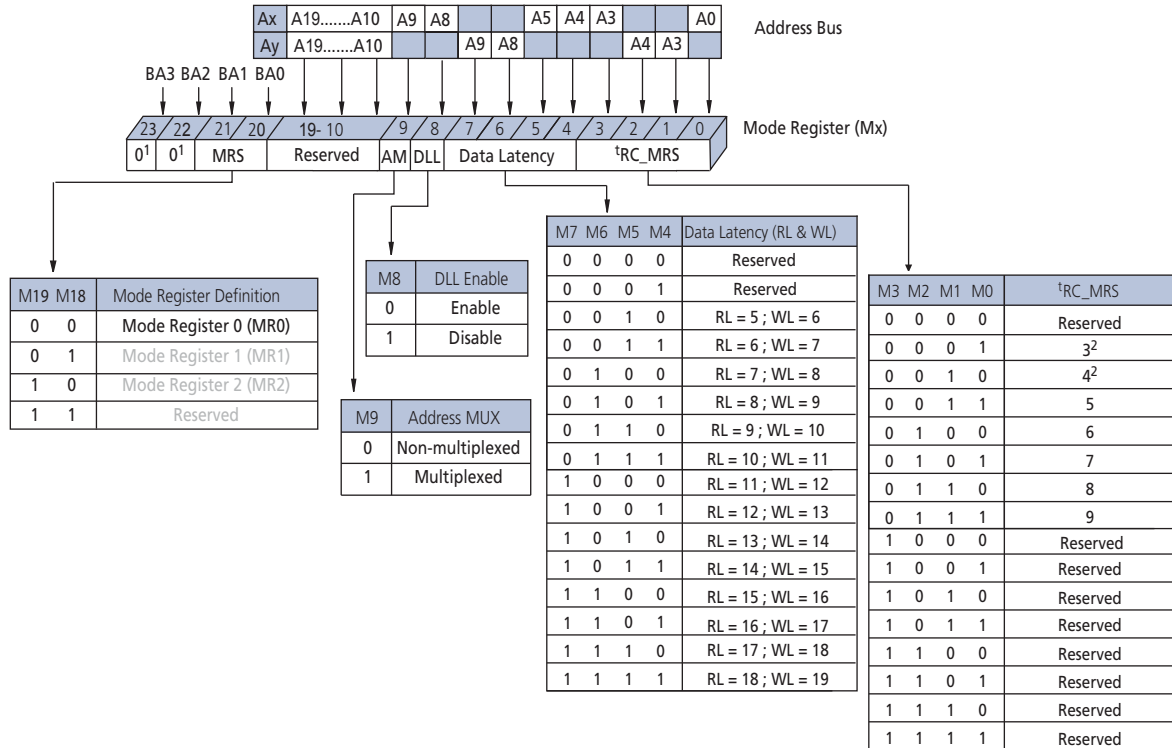

- Notes:
1. BA2, BA3, and all address balls corresponding to reserved bits must be held LOW during the MRS command.
 2. BL8 not allowed.

Figure 62: MR1 Definition for Multiplexed Address Mode

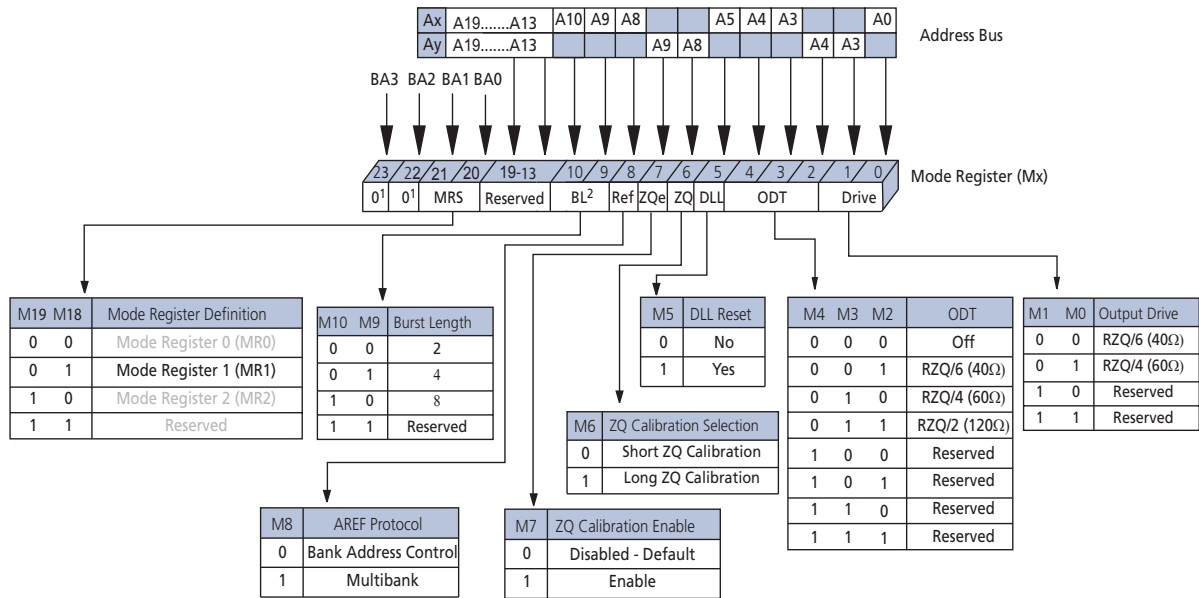

- Notes:
1. BA2, BA3, and all address balls corresponding to reserved bits must be held LOW during the MRS command.
 2. BL8 not available in x36.

Figure 63: MR2 Definition for Multiplexed Address Mode

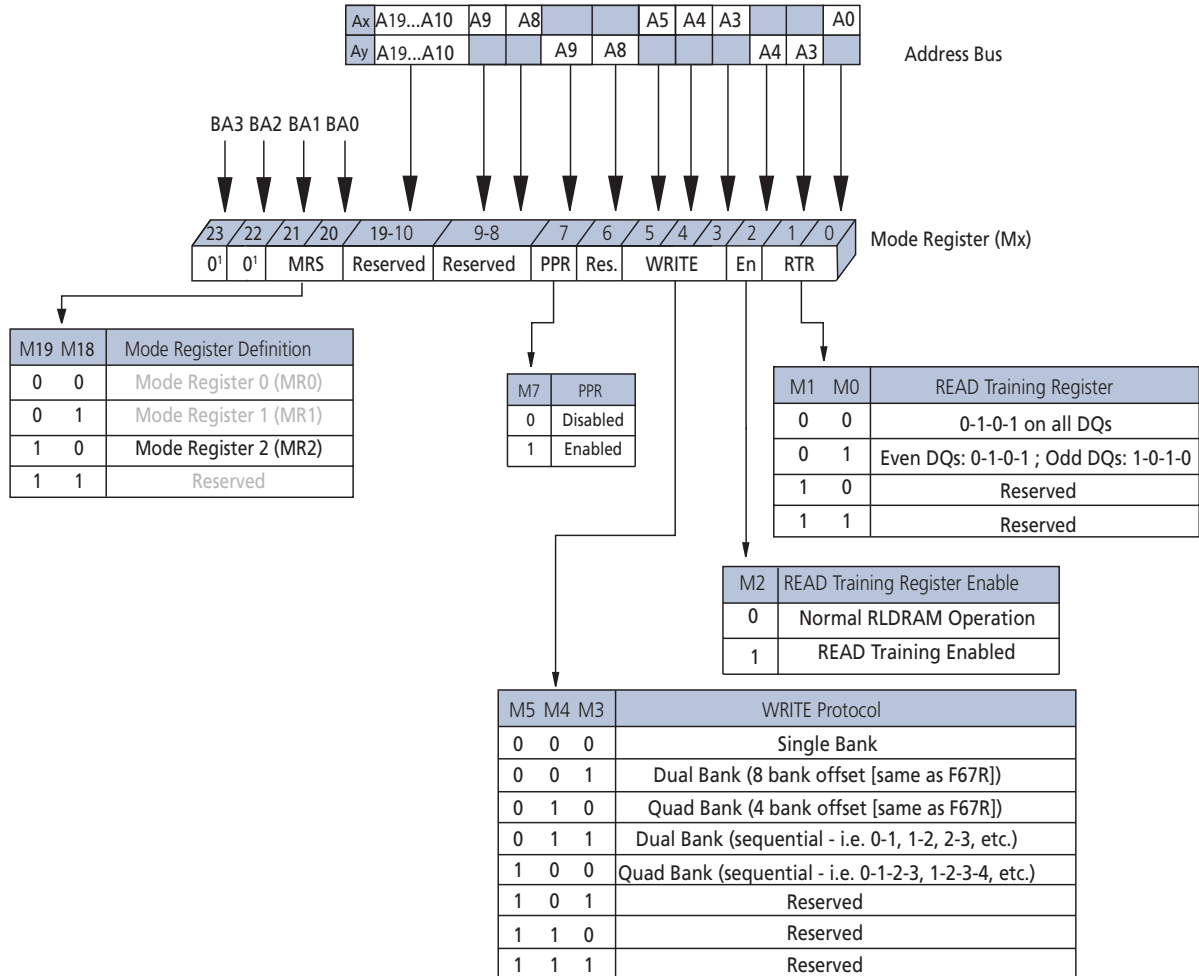

Note: 1. BA2, BA3, and all address balls corresponding to reserved bits must be held LOW during the MRS command.

Table 46: Address Mapping in Multiplexed Address Mode

Data Width	Burst Length	Ball	Address										
			A0	A3	A4	A5	A8	A9	A10	A13	A14	A17	A18
x36	2	Ax	A0	A3	A4	A5	A8	A9	A10	A13	A14	A17	A18
		Ay	X	A1	A2	X	A6	A7	X	A11	A12	A16	A15
	4	Ax	A0	A3	A4	A5	A8	A9	A10	A13	A14	A17	X
		Ay	X	A1	A2	X	A6	A7	X	A11	A12	A16	A15

Table 46: Address Mapping in Multiplexed Address Mode (Continued)

Data Width	Burst Length	Ball	Address										
			A0	A3	A4	A5	A8	A9	A10	A13	A14	A17	A18
x18	2	Ax	A0	A3	A4	A5	A8	A9	A10	A13	A14	A17	A18
		Ay	X	A1	A2	X	A6	A7	A19	A11	A12	A16	A15
	4	Ax	A0	A3	A4	A5	A8	A9	A10	A13	A14	A17	A18
		Ay	X	A1	A2	X	A6	A7	X	A11	A12	A16	A15
	8	Ax	A0	A3	A4	A5	A8	A9	A10	A13	A14	A17	X
		Ay	X	A1	A2	X	A6	A7	X	A11	A12	A16	A15

Note: 1. X = "Don't Care"

Data Latency in Multiplexed Address Mode

When in multiplexed address mode, data latency (READ and WRITE) begins when the Ay part of the address is issued with any READ or WRITE command. ^tRC is measured from the clock edge in which the command and Ax part of the address is issued in both multiplexed and non-multiplexed address mode.

REFRESH Command in Multiplexed Address Mode

Similar to other commands when in multiplexed address mode, both modes of AREF (single and multibank) are executed on the rising clock edge, following the one on which the command is issued. However, when in bank address-controlled AREF, as only the bank address is required, the next command can be applied on the following clock. When using multibank AREF, the bank addresses are mapped across Ax and Ay so a subsequent command cannot be issued until two clock cycles later.

Figure 64: Bank Address-Controlled AUTO REFRESH Operation with Multiplexed Addressing

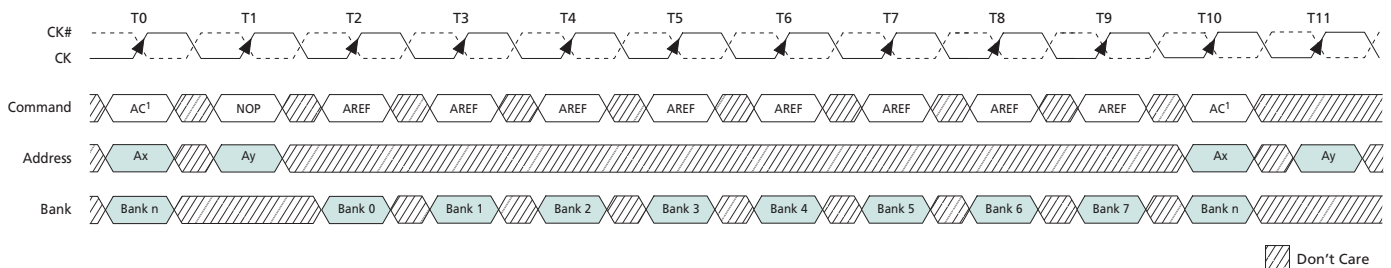

Note: 1. Any command subject to ^tRC specification.

Figure 65: Multibank AUTO REFRESH Operation with Multiplexed Addressing

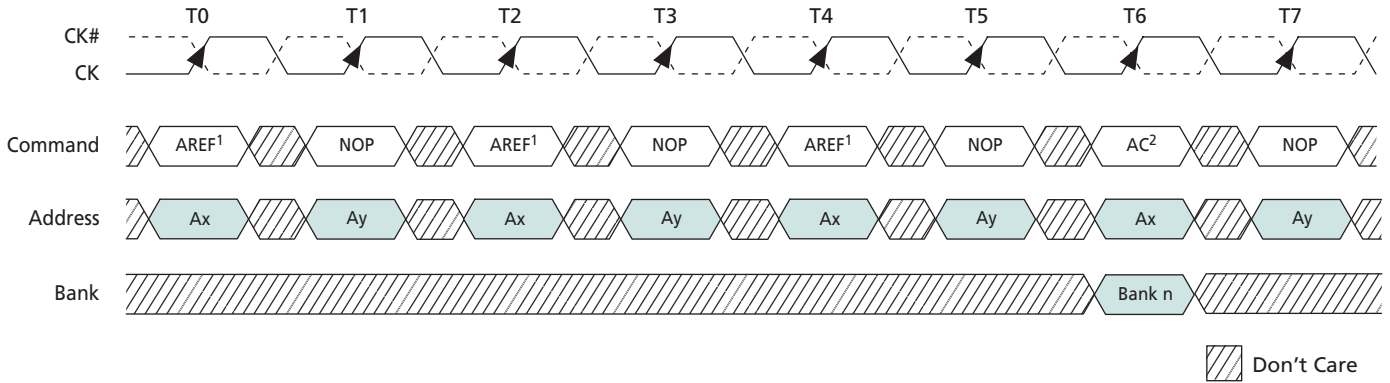

- Notes: 1. Usage of multibank AREF subject to t_{SAW} and t_{MMD} specifications.
2. Any command subject to t_{RC} specification.

Figure 66: Consecutive WRITE Bursts with Multiplexed Addressing

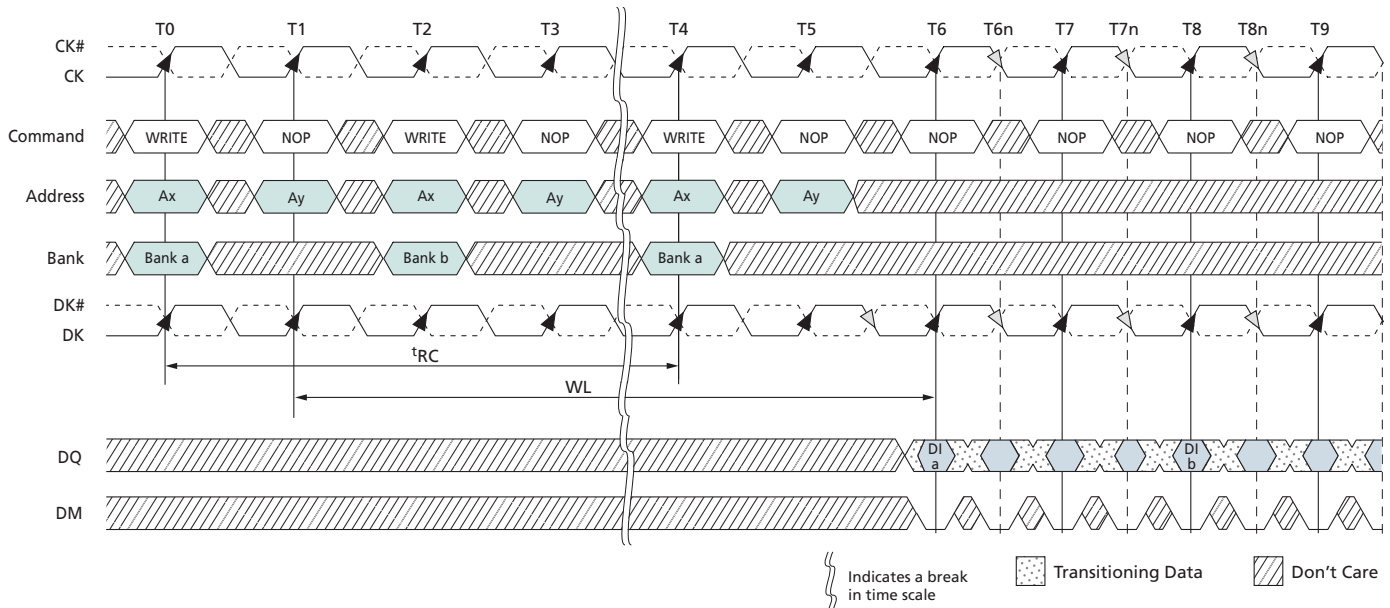

- Note: 1. DI a = data-in for bank a; DI b = data-in for bank b.

Figure 67: WRITE-to-READ with Multiplexed Addressing

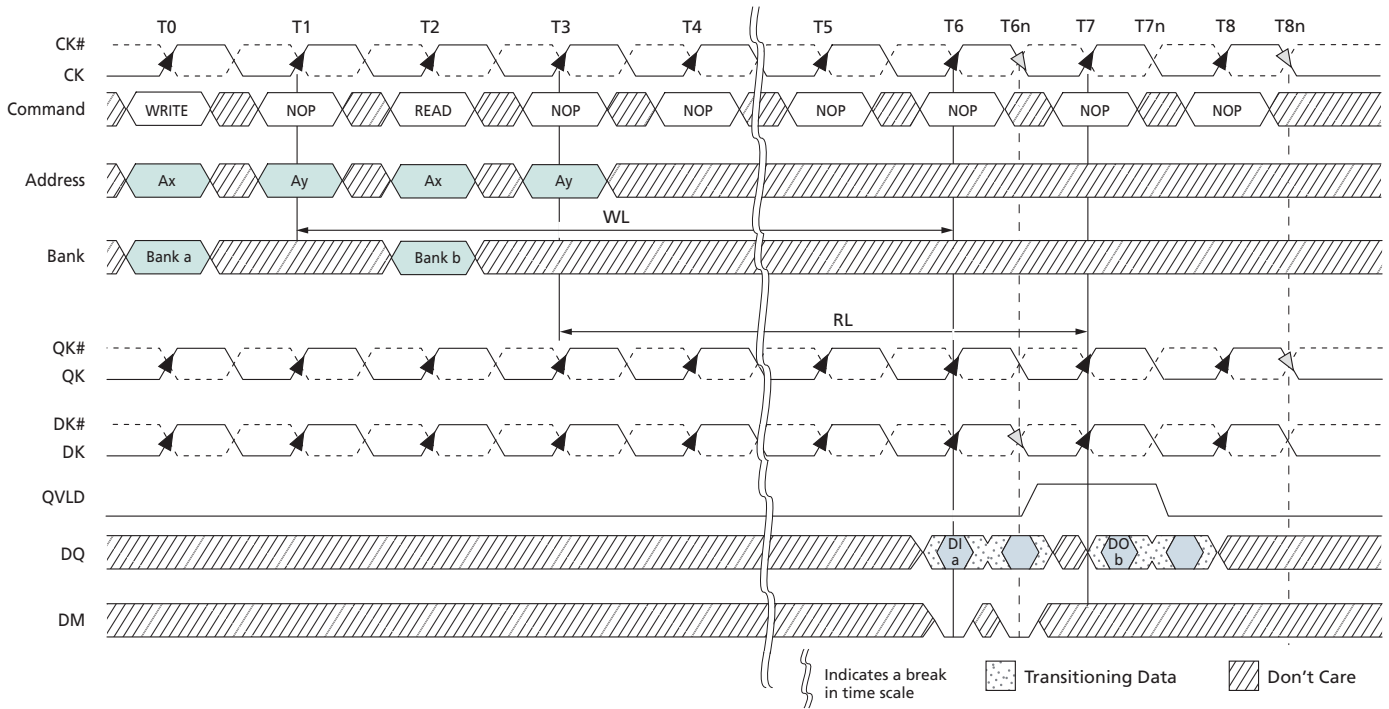

Note: 1. DI a = data-in for bank a; DI b = data-in for bank b.

Figure 68: Consecutive READ Bursts with Multiplexed Addressing

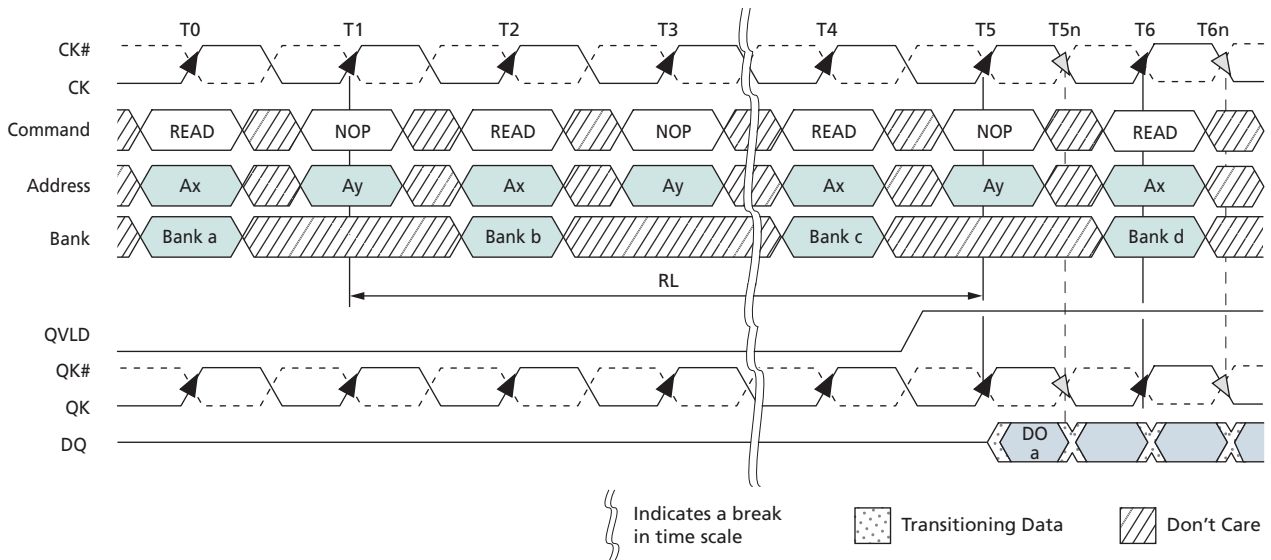

Note: 1. DO a = data-out for bank a.

Figure 69: READ-to-WRITE with Multiplexed Addressing

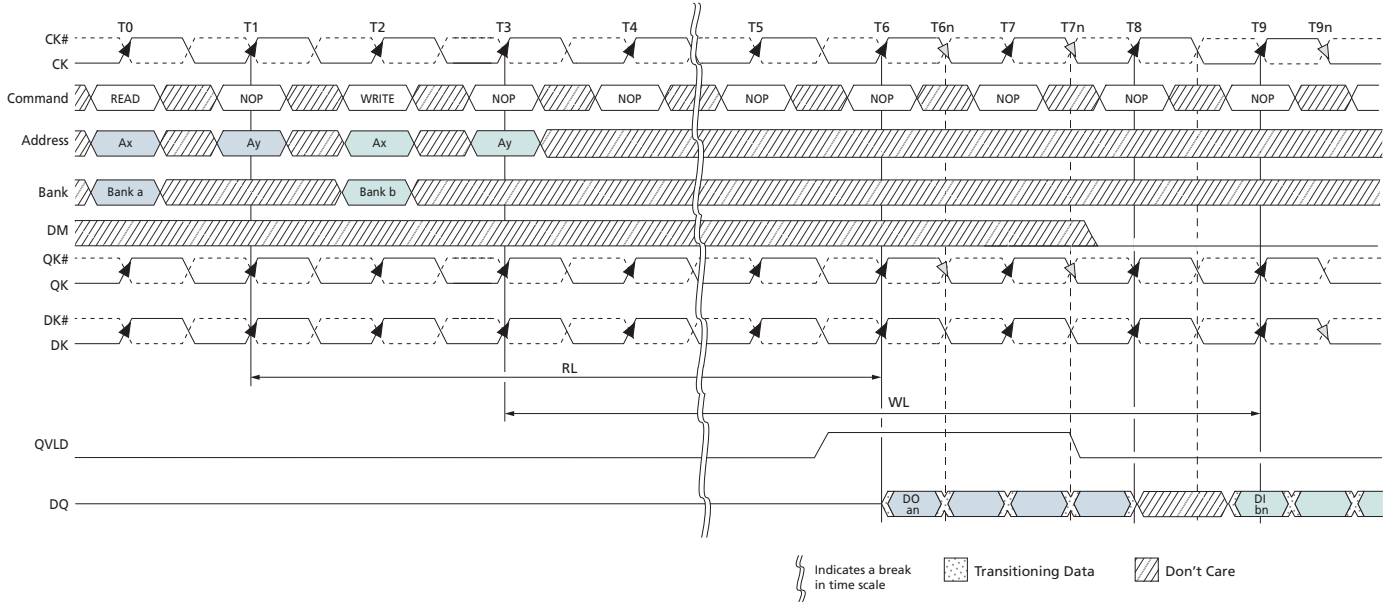

Note: 1. DO a = data-out for bank a; DI b = data-in for bank b.



IEEE 1149.1 Serial Boundary Scan (JTAG)

The RLDRAM 3 device incorporates a serial boundary-scan test access port (TAP) for the purpose of testing the connectivity of the device after it has been mounted on a printed circuit board (PCB). As the complexity of PCB high-density surface mounting techniques increases, the boundary-scan architecture is a valuable resource for interconnectivity debug. This port operates in accordance with IEEE Standard 1149.1-2001 (JTAG) with the exception of the ZQ pin. To ensure proper boundary-scan testing of the ZQ pin, MR1[7] needs to be set to 0 until the JTAG testing of the pin is complete. Note that upon power up, the default state of the MRS bit M1[7] is low.

The JTAG test access port utilizes the TAP controller on the device, from which the instruction register, boundary-scan register, bypass register, and ID register can be selected. Each of these functions of the TAP controller is described in detail below.

Disabling the JTAG Feature

It is possible to operate an RLDRAM 3 device without using the JTAG feature. To disable the TAP controller, TCK must be tied LOW (V_{SS}) to prevent clocking of the device. TDI and TMS are internally pulled up and may be unconnected. They may alternately be connected to V_{DDQ} through a pull-up resistor. TDO should be left unconnected. Upon power-up, the device will come up in a reset state, which will not interfere with the operation of the device.

Test Access Port (TAP)

Test Clock (TCK)

The test clock is used only with the TAP controller. All inputs are captured on the rising edge of TCK. All outputs are driven from the falling edge of TCK.

Test Mode Select (TMS)

The TMS input is used to give commands to the TAP controller and is sampled on the rising edge of TCK.

All the states in Figure 70 are entered through the serial input of the TMS ball. A 0 in the diagram represents a LOW on the TMS ball during the rising edge of TCK, while a 1 represents a HIGH on TMS.

Test Data-In (TDI)

The TDI ball is used to serially input test instructions and data into the registers and can be connected to the input of any of the registers. The register between TDI and TDO is chosen by the instruction that is loaded into the TAP instruction register. For information on loading the instruction register, see Figure 70. TDI is connected to the most significant bit (MSB) of any register (see Figure 71).

Test Data-Out (TDO)

The TDO output ball is used to serially clock test instructions and data out from the registers. The TDO output driver is only active during the Shift-IR and Shift-DR TAP controller states. In all other states, the TDO ball is in a High-Z state. The output changes on the falling edge of TCK. TDO is connected to the least significant bit (LSB) of any register (see Figure 71).



TAP Controller

The TAP controller is a finite state machine that uses the state of the TMS ball at the rising edge of TCK to navigate through its various modes of operation (see Figure 70). Each state is described in detail below.

Test-Logic-Reset

The test-logic-reset controller state is entered when TMS is held HIGH for at least five consecutive rising edges of TCK. As long as TMS remains HIGH, the TAP controller will remain in the test-logic-reset state. The test logic is inactive during this state.

Run-Test/Idle

The run-test/idle is a controller state in between scan operations. This state can be maintained by holding TMS LOW. From there, either the data register scan, or subsequently, the instruction register scan, can be selected.

Select-DR-Scan

Select-DR-scan is a temporary controller state. All test data registers retain their previous state while here.

Capture-DR

The capture-DR state is where the data is parallel-loaded into the test data registers. If the boundary-scan register is the currently selected register, then the data currently on the balls is latched into the test data registers.

Shift-DR

Data is shifted serially through the data register while in this state. As new data is input through the TDI ball, data is shifted out of the TDO ball.

Exit1-DR, Pause-DR, and Exit2-DR

The purpose of exit1-DR is used to provide a path to return back to the run-test/idle state (through the update-DR state). The pause-DR state is entered when the shifting of data through the test registers needs to be suspended. When shifting is to reconvene, the controller enters the exit2-DR state and then can re-enter the shift-DR state.

Update-DR

When the EXTEST instruction is selected, there are latched parallel outputs of the boundary-scan shift register that only change state during the update-DR controller state.

Instruction Register States

The instruction register states of the TAP controller are similar to the data register states. The desired instruction is serially shifted into the instruction register during the shift-IR state and is loaded during the update-IR state.

Figure 70: TAP Controller State Diagram

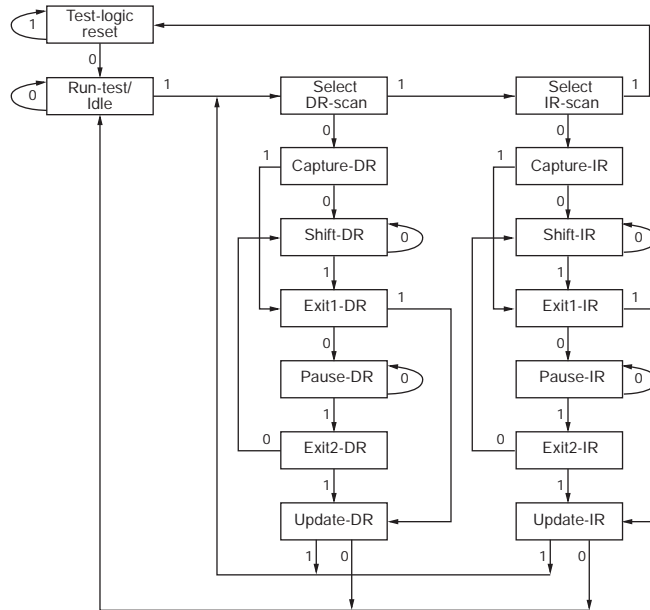
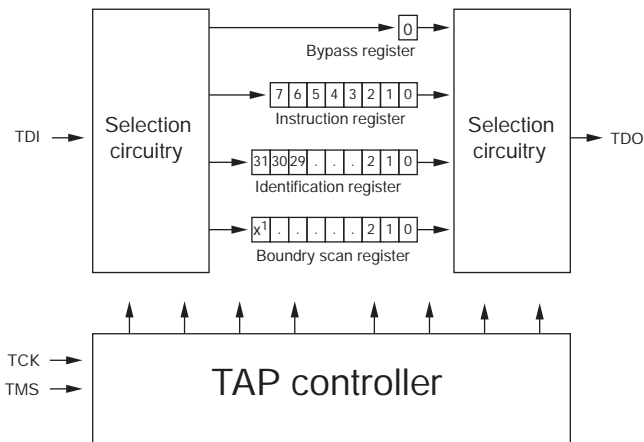

Figure 71: TAP Controller Functional Block Diagram



Note: 1. x = 135 for the standard product, and 121 for the alternative product.



Performing a TAP RESET

A reset is performed by forcing TMS HIGH (V_{DDQ}) for five rising edges of t_{CK} . This RESET does not affect the operation of the device and may be performed while the device is operating.

At power-up, the TAP is reset internally to ensure that TDO comes up in a High-Z state. If JTAG inputs cannot be guaranteed to be stable during power-up it is recommended that TMS be held HIGH for at least 5 consecutive TCK cycles prior to boundary scan testing.

TAP Registers

Registers are connected between the TDI and TDO balls and allow data to be scanned into and out of the RLD RAM 3 device test circuitry. Only one register can be selected at a time through the instruction register. Data is serially loaded into the TDI ball on the rising edge of TCK. Data is output on the TDO ball on the falling edge of TCK.

Instruction Register

Eight-bit instructions can be serially loaded into the instruction register. This register is loaded during the update-IR state of the TAP controller. Upon power-up, the instruction register is loaded with the IDCODE instruction. It is also loaded with the IDCODE instruction if the controller is placed in a reset state as described in the previous section.

When the TAP controller is in the capture-IR state, the two LSBs are loaded with a binary 01 pattern to allow for fault isolation of the board-level serial test data path.

Bypass Register

To save time when serially shifting data through registers, it is sometimes advantageous to skip certain chips. The bypass register is a single-bit register that can be placed between the TDI and TDO balls. This enables data to be shifted through the device with minimal delay. The bypass register is set LOW (V_{SS}) when the BYPASS instruction is executed.

Boundary-Scan Register

The boundary-scan register is connected to all the input and bidirectional balls on the device. Several balls are also included in the scan register to reserved balls. The device has a 135-bit register as standard, or 121-bit register as an alternative.

The boundary-scan register is loaded with the contents of the RAM I/O ring when the TAP controller is in the capture-DR state and is then placed between the TDI and TDO balls when the controller is moved to the shift-DR state.

The order in which the bits are connected is shown in Table 49. Each bit corresponds to one of the balls on the RLD RAM package. The MSB of the register is connected to TDI, and the LSB is connected to TDO.

Identification (ID) Register

The ID register is loaded with a vendor-specific, 32-bit code during the capture-DR state when the IDCODE command is loaded in the instruction register. The IDCODE is hardwired into the RLD RAM 3 and can be shifted out when the TAP controller is in the shift-DR state. The ID register has a vendor code and other information described in Table 46.



TAP Instruction Set

Overview

There are 2^8 different instructions possible with the 8-bit instruction register. All combinations used are listed in Table 48. These six instructions are described in detail below. The remaining instructions are reserved and should not be used.

The TAP controller used in this RLD RAM 3 device is fully compliant to the IEEE 1149.1 convention.

Instructions are loaded into the TAP controller during the shift-IR state when the instruction register is placed between TDI and TDO. During this state, instructions are shifted through the instruction register through the TDI and TDO balls. To execute the instruction after it is shifted in, the TAP controller needs to be moved into the update-IR state.

EXTEST

The EXTEST instruction enables circuitry external to the component package to be tested. Boundary-scan register cells at output balls are used to apply a test vector, while those at input balls capture test results. Typically, the first test vector to be applied using the EXTEST instruction will be shifted into the boundary-scan register using the PRELOAD instruction. Thus, during the update-IR state of EXTEST, the output driver is turned on, and the PRELOAD data is driven onto the output balls.

IDCODE

The IDCODE instruction causes a vendor-specific, 32-bit code to be loaded into the instruction register. It also places the instruction register between the TDI and TDO balls and enables the IDCODE to be shifted out of the device when the TAP controller enters the shift-DR state. The IDCODE instruction is loaded into the instruction register upon power-up or whenever the TAP controller is given a test logic reset state.

High-Z

The High-Z instruction causes the bypass register to be connected between the TDI and TDO. This places all RLD RAM outputs into a High-Z state.

CLAMP

When the CLAMP instruction is loaded into the instruction register, the data driven by the output balls are determined from the values held in the boundary-scan register.

SAMPLE/PRELOAD

When the SAMPLE/PRELOAD instruction is loaded into the instruction register and the TAP controller is in the capture-DR state, a snapshot can be taken of the states of the component's input and output signals without interfering with the normal operation of the assembled board. The snapshot is taken on the rising edge of TCK and is captured in the boundary-scan register. The data can then be viewed by shifting through the component's TDO output.

The user must be aware that the TAP controller clock can only operate at a frequency up to 50 MHz, while the RLD RAM 3 clock operates significantly faster. Because there is a large difference between the clock frequencies, it is possible that during the capture-DR state, an input or output will undergo a transition. The TAP may then try to capture a signal while in transition (metastable state). This will not harm the device, but there is

no guarantee as to the value that will be captured. Repeatable results may not be possible.

To ensure that the boundary-scan register will capture the correct value of a signal, the RLD RAM signal must be stabilized long enough to meet the TAP controller's capture setup plus hold time (t_{CS} plus t_{CH}). The RLD RAM clock input might not be captured correctly if there is no way in a design to stop (or slow) the clock during a SAMPLE/PRELOAD instruction. If this is an issue, it is still possible to capture all other signals and simply ignore the value of the CK and CK# captured in the boundary-scan register.

After the data is captured, it is possible to shift out the data by putting the TAP into the shift-DR state. This places the boundary-scan register between the TDI and TDO balls.

BYPASS

When the BYPASS instruction is loaded in the instruction register and the TAP is placed in a shift-DR state, the bypass register is placed between TDI and TDO. The advantage of the BYPASS instruction is that it shortens the boundary-scan path when multiple devices are connected together on a board.

Reserved for Future Use

The remaining instructions are not implemented but are reserved for future use. Do not use these instructions.

Figure 72: JTAG Operation - Loading Instruction Code and Shifting Out Data

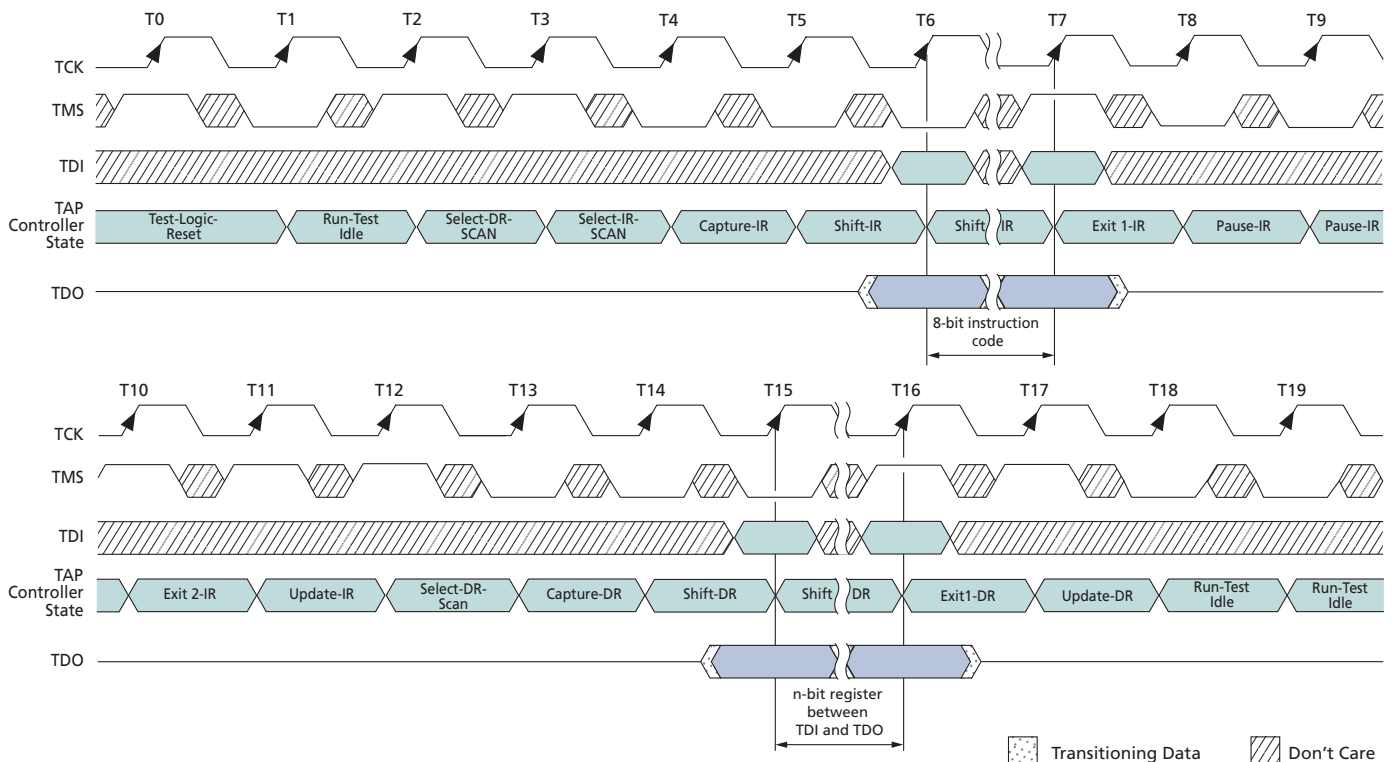

Figure 73: TAP Timing

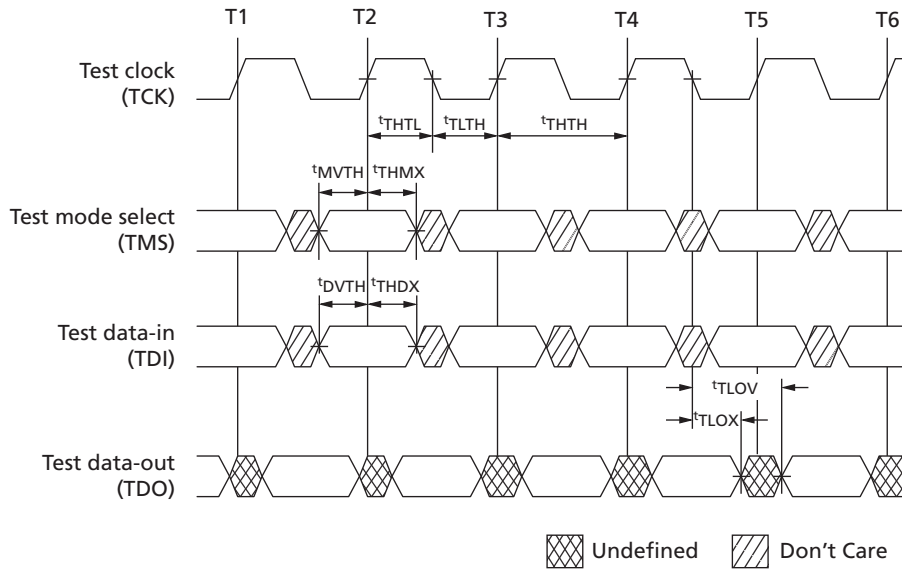

Table 47: TAP Input AC Logic Levels

0°C ≤ T_C ≤ +95°C; +1.28V ≤ V_{DD} ≤ +1.42V, unless otherwise noted

Description	Symbol	Min	Max	Units
Input HIGH (logic 1) voltage	V _{IH}	V _{REF} + 0.225	-	V
Input LOW (logic 0) voltage	V _{IL}	-	V _{REF} - 0.225	V

Note: 1. All voltages referenced to V_{SS} (GND).

Table 48: TAP AC Electrical Characteristics

0°C ≤ T_C ≤ +95°C; +1.28V ≤ V_{DD} ≤ +1.42V

Description	Symbol	Min	Max	Units
Clock				
Clock cycle time	t _{THH}	20		ns
Clock frequency	f _{TF}		50	MHz
Clock HIGH time	t _{THL}	10		ns
Clock LOW time	t _{TLH}	10		ns
TDI/TDO times				
TCK LOW to TDO unknown	t _{TLOX}	0		ns
TCK LOW to TDO valid	t _{TLOV}		10	ns
TDI valid to TCK HIGH	t _{DVTH}	5		ns
TCK HIGH to TDI invalid	t _{THDX}	5		ns
Setup times				
TMS setup	t _{MVTH}	5		ns



Table 48: TAP AC Electrical Characteristics (Continued)

$0^{\circ}\text{C} \leq T_C \leq +95^{\circ}\text{C}$; $+1.28\text{V} \leq V_{DD} \leq +1.42\text{V}$

Description	Symbol	Min	Max	Units
Capture setup	t^1_{CS}	5		ns
Hold times				
TMS hold	t^1_{THMX}	5		ns
Capture hold	t^1_{CH}	5		ns

Note: 1. t^1_{CS} and t^1_{CH} refer to the setup and hold time requirements of latching data from the boundary-scan register.

Table 49: TAP DC Electrical Characteristics and Operating Conditions

$0^{\circ}\text{C} \leq T_C \leq +95^{\circ}\text{C}$; $+1.28\text{V} \leq V_{DD} \leq +1.42\text{V}$, unless otherwise noted

Description	Condition	Symbol	Min	Max	Units	Notes
Input HIGH (logic 1) voltage		V_{IH}	$V_{REF} + 0.15$	V_{DDQ}	V	1, 2
Input LOW (logic 0) voltage		V_{IL}	V_{SSQ}	$V_{REF} - 0.15$	V	1, 2
Input leakage current	$0\text{V} \leq V_{IN} \leq V_{DD}$	I_{LI}	-5.0	5.0	μA	
Output leakage current	Output disabled, $0\text{V} \leq V_{IN} \leq V_{DDQ}$	I_{LO}	-5.0	5.0	μA	
Output low voltage	$I_{OLC} = 100\mu\text{A}$	V_{OL1}		0.2	V	1
Output low voltage	$I_{OLT} = 2\text{mA}$	V_{OL2}		0.4	V	1
Output high voltage	$ I_{OHC} = 100\mu\text{A}$	V_{OH1}	$V_{DDQ} - 0.2$		V	1
OUTPUT HIGH VOLTAGE	$ I_{OHT} = 2\text{mA}$	V_{OH2}	$V_{DDQ} - 0.4$		V	1

Notes: 1. All voltages referenced to $V_{SS}(\text{GND})$.
2. See AC Overshoot/Undershoot Specifications section for overshoot and undershoot limits.

Table 50: Scan Register Sizes

Register Name	Bit Size
Instruction	8
Bypass	1
ID	32
Boundary scan	135 (Standard), 121 (Alternative)

Note: Refer to Ordering Information for selection of Standard or Alternative option.



Table 51: Instruction Codes

Instruction	Code	Description
Exttest	0000 0000	Captures I/O ring contents; Places the boundary-scan register between TDI and TDO; This operation does not affect RLDRAM 3 operations.
ID code	0010 0001	Loads the ID register with the vendor ID code and places the register between TDI and TDO; This operation does not affect RLDRAM 3 operations.
Sample/preload	0000 0101	Captures I/O ring contents; Places the boundary-scan register between TDI and TDO.
Clamp	0000 0111	Selects the bypass register to be connected between TDI and TDO; Data driven by output balls are determined from values held in the boundary-scan register.
High-Z	0000 0011	Selects the bypass register to be connected between TDI and TDO; All outputs are forced into High-Z.
Bypass	1111 1111	Places the bypass register between TDI and TDO; This operation does not affect RLDRAM operations.

Table 52: Identification (ID) Code Definition

Instruction Field	All Devices	Description
Revision number (31:28)	abcd	ab = 00 for Die Revision A cd = 00 for x18, 01 for x36
Device ID (27:12)	00jkidef10100111	def = 000 for 576Mb, 001 for 1Gb Double Die Package, 010 for 1Gb Monolithic i = 0 for common I/O, 1 for separate I/O jk = 10 for RLDRAM 3
ISSI JEDEC ID code (11:1)	000 1101 0101	Enables unique identification of RLDRAM vendor
ID register presence indicator (0)	1	Indicates the presence of an ID register

Table 53: MR0_MR1 Mode Register Settings Definition

Instruction Field	All Devices	Description
Not Defined (31:29)	xxx	Not defined and will be 0
MR1 (28:17)	MR1[11:0]	MR1 spec sheet latched bits
Not Defined (16:14)	xxx	Not defined and will be 0
Post Package Repair Capable (13)	PPR	PPR = 0 when device is not PPR Capable PPR = 1 when device is PPR Capable
MR0 (12:1)	MR0[11:0]	MR0 spec sheet latched bits
MR0_MR1 register indicator (0)	1	Indicates the presence of the MR0_MR1 register



Table 54: MR2 Mode Register Settings Definition

Instruction Field	All Devices	Description
Not Defined (31:11)	xxx	Not defined
MR2 (10:1)	MR2[9:0]	MR2 spec sheet latched bits;
MR2 register indicator (0)	1	Indicates the presence of the MR2 register



Table 55: Boundary Scan for 135 cells (Exit)

Bit#	Ball	Bit#	Ball	Bit#	Ball
1	N8	46	D9	91	N6
2	N8	47	L7	92	M3
3	M11	48	K7	93	M3
4	M11	49	H1	94	M5
5	M9	50	H3	95	M5
6	M9	51	H4	96	L2
7	L12	52	G2	97	L2
8	L12	53	G3	98	L4
9	L10	54	F1	99	L4
10	L10	55	H6	100	L6
11	L8	56	G5	101	L6
12	L8	57	G4	102	K1
13	K13	58	G1	103	K1
14	K13	59	F6	104	K3
15	K11	60	E2	105	K3
16	K11	61	F5	106	J4
17	J10	62	F4	107	J4
18	J10	63	F2	108	J6
19	J8	64	D1	109	J6
20	J8	65	F7	110	K5
21	K9	66	D7	111	K5
22	K9	67	C7	112	J2
23	J12	68	A13	113	J2
24	J12	69	B7	114	A4
25	A10	70	E7	115	A4
26	A10	71	D13	116	A6
27	A8	72	F12	117	A6
28	A8	73	F10	118	B3
29	B11	74	F9	119	B3
30	B11	75	E12	120	B5
31	B9	76	G13	121	B5
32	B9	77	G10	122	C2
33	C12	78	F8	123	C2
34	C12	79	G7	124	C4
35	C10	80	H7	125	C4
36	C10	81	G9	126	C6
37	C8	82	H8	127	C6
38	C8	83	F13	128	E4



Table 55: Boundary Scan for 135 cells (Exit) (Continued)

Bit#	Ball	Bit#	Ball	Bit#	Ball
39	E10	84	G11	129	E4
40	E10	85	G12	130	D3
41	D11	86	H10	131	D3
42	D11	87	H11	132	E6
43	E8	88	H13	133	E6
44	E8	89	M7	134	D5
45	D9	90	N6	135	D5

Table 56: Boundary Scan for 121 cells (Exit)

Bit#	Ball	Bit#	Ball	Bit#	Ball
1	N8	42	L7	83	M3
2	N8	43	K7	84	M3
3	M11	44	H1	85	M5
4	M11	45	H4	86	M5
5	M9	46	G2	87	L2
6	M9	47	G3	88	L2
7	L12	48	F1	89	L4
8	L12	49	F5	90	L4
9	L10	50	F4	91	L6
10	L10	51	F2	92	L6
11	L8	52	D1	93	K1
12	L8	53	F7	94	K1
13	K13	54	D7	95	K3
14	K13	55	C7	96	K3
15	K11	56	A13	97	J4
16	K11	57	B7	98	J4

Note: Table 56 continued on next page.



Table 56: Boundary Scan for 121 cells (Exit) (Continued)

Bit#	Ball	Bit#	Ball	Bit#	Ball
17	J10	58	E7	99	J6
18	J10	59	D13	100	K5
19	J8	60	F12	101	J2
20	K9	61	F10	102	A4
21	J12	62	F9	103	A4
22	A10	63	E2	104	A6
23	A10	64	E12	105	A6
24	A8	65	F6	106	B3
25	A8	66	F8	107	B3
26	B11	67	G7	108	B5
27	B11	68	H7	109	B5
28	B9	69	G5	110	C2
29	B9	70	G9	111	C2
30	C12	71	H6	112	C4
31	C12	72	H8	113	C4
32	C10	73	F13	114	C6
33	C10	74	G11	115	C6
34	C8	75	G12	116	E4
35	C8	76	H10	117	E4
36	E10	77	H3	118	D3
37	E10	78	H11	119	D3
38	D11	79	H13	120	E6
39	D11	80	M7	121	D5
40	E8	81	N6	-	-
41	D9	82	N6	-	-



Table 57: Ordering Information

Commercial Range: Tc = 0°C to +95°C

Freq.	Speed (tCK)	tRC(min)	Order Part No.	Org.	No. of Boundary Cells	Package
1066MHz	0.93ns	7.5ns	IS49RL18320A-093FBL	32M x 18	135	168 FBGA, green
			IS49RL18320A-093FB2L		121	
			IS49RL36160A-093FBL	16M x 36	135	
			IS49RL36160A-093FB2L		121	
		8.0ns	IS49RL18320A-093EBL	32M x 18	135	
			IS49RL18320A-093EB2L		121	
			IS49RL36160A-093EBL	16M x 36	135	
			IS49RL36160A-093EB2L		121	
933MHz	1.07ns	8.0ns	IS49RL18320A-107EBL	32M x 18	135	
			IS49RL18320A-107EB2L		121	
			IS49RL36160A-107EBL	16M x 36	135	
			IS49RL36160A-107EB2L		121	

Industrial Range: Tc = -40°C to +95°C

Freq.	Speed (tCK)	tRC(min)	Order Part No.	Org.	No. of Boundary Cells	Package
1066MHz	0.93ns	7.5ns	IS49RL18320A-093FBLI	32M x 18	135	168 FBGA, green
			IS49RL18320A-093FB2LI		121	
			IS49RL36160A-093FBLI	16M x 36	135	
			IS49RL36160A-093FB2LI		121	
		8.0ns	IS49RL18320A-093EBLI	32M x 18	135	
			IS49RL18320A-093EB2LI		121	
			IS49RL36160A-093EBLI	16M x 36	135	
			IS49RL36160A-093EB2LI		121	
933MHz	1.07ns	8.0ns	IS49RL18320A-107EBLI	32M x 18	135	
			IS49RL18320A-107EB2LI		121	
			IS49RL36160A-107EBLI	16M x 36	135	
			IS49RL36160A-107EB2LI		121	

Note:

1. The terminology "green" refers to the package being Halogen-free, RoHS and TSCA Compliant.
2. Optionally, the code -TR may be appended to a part number to indicate Tape & Reel packing format.

168-Ball FBGA Package drawing – 13.5x13.5x1.25mm BGA

