

## OCXO Part No: OS560-1005-024

Issue 2; 9th May 2022

### Features

- Temperature stability  $\pm 10$ ppb
- Low phase noise
- Frequency 10MHz
- Low pre-aged options available
- The flexible nature of the design means that variations to suit almost any application can be developed to meet individual customer requirements



### Option B

- Temperature stability:  $\pm 10$ ppb over  $(-20$  to  $+70)^{\circ}\text{C}$
- Output: CMOS 15 pF, 45% 55%
- Voltage: 3.3V
- Warm up current: 720mA
- Quiescent current: 320mA

### Phase Noise (typical)

- $F_{0}+10\text{Hz}$  -128 dBc/Hz
- $F_{0}+100\text{Hz}$  -145 dBc/Hz
- $F_{0}+1\text{KHz}$  -155 dBc/Hz
- $F_{0}+10\text{KHz}$  -160 dBc/Hz
- $F_{0}+100\text{KHz}$  -168 dBc/Hz

### Voltage / Load change

- $\pm 5\%$  supply voltage change:  $\pm 2$ ppb
- $\pm 10\%$  load change:  $\pm 10$ ppb

### Aging

After 30 days continuous operation:

- Per day:  $\pm 0.1$ ppb max.
- Per year:  $\pm 50$ ppb max.
- Warm up time: 5 minutes to within 0.1 ppm

### Voltage Trim

- $\pm 0.5$ ppm minimum
- Trim impedance 50K $\Omega$

### Reference Options

- 3.0V

### Environmental

- Electrostatic-Sensitive Device (ESD)
- Storage Temperature Range:  $(-40$  to  $+125)^{\circ}\text{C}$
- Mechanical shock: MIL standard 202, method 213, condition J

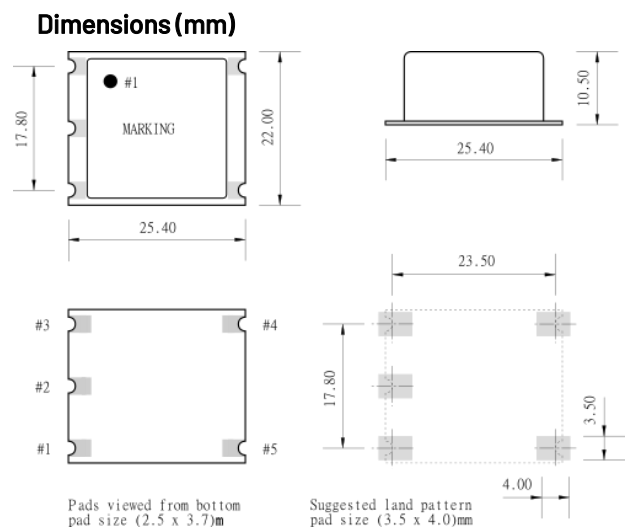

### Phase Noise Plot

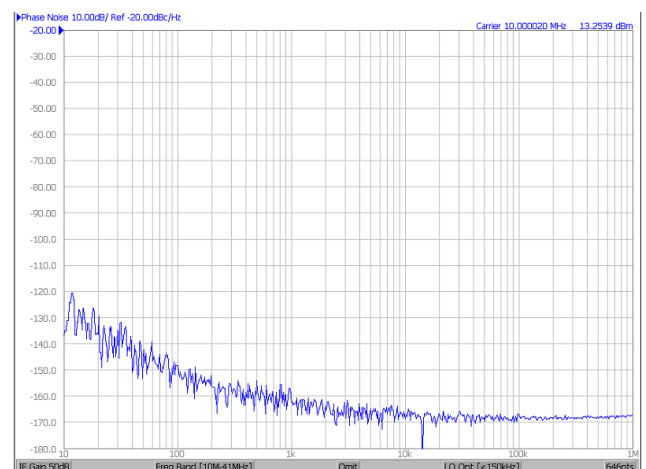

- Thermal shock: MIL standard 202, method 107, condition A
- Vibration: MIL standard 202, method 204, condition B
- Solderability: 5 seconds maximum at 230°C
- 3 seconds maximum at 350°C

#### Compliance

- RoHS Status (2011/65/EU) - Compliant
- REACH Status - Compliant

#### Packaging

- Pack Style: Bulk

#### Ordering Information

- Unique customer part number and custom specification issued with each application
- OCXO Part No: OS560-1005-024
- Frequency: 10MHz

#### Test Circuit - CMOS

