

## ● Features:

1. Chip material: AlInGaN
2. Emitted color : Green
3. Lens Appearance : Water Clear
4. Low power consumption.
5. High efficiency.
6. Versatile mounting on P.C. Board or panel.
7. Low current requirement.
8. 5mm diameter package.
9. This product don't contained restriction substance, compliance ROHS standard.

## ● Applications:

1. TV set
2. Monitor
3. Telephone
4. Computer
5. Circuit board

## ● Package dimensions:

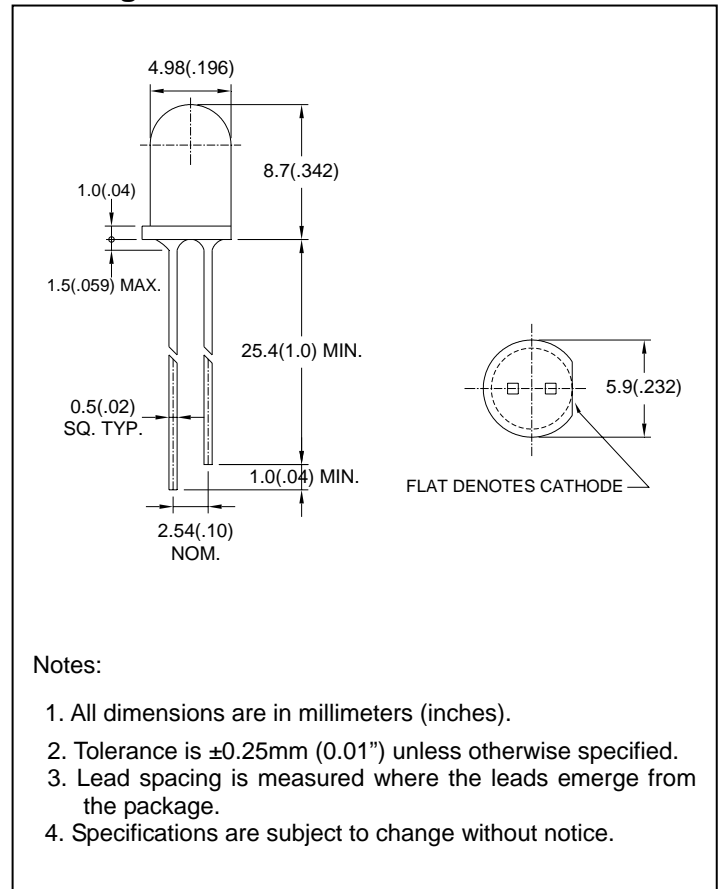

## ● Absolute maximum ratings(Ta=25°C)

Parameter	Symbol	Rating	Unit
Power Dissipation	Pd	120	mW
Forward Current	I <sub>F</sub>	30	mA
Peak Forward Current* <sup>1</sup>	I <sub>FP</sub>	150	mA
Reverse Voltage	V <sub>R</sub>	5	V
Operating Temperature	T <sub>opr</sub>	-40°C~85°C	
Storage Temperature	T <sub>stg</sub>	-40°C~100°C	
Soldering Temperature	T <sub>sol</sub>	260°C (for 5 seconds)	

\*<sup>1</sup>Condition for I<sub>FP</sub> is pulse of 1/10 duty and 0.1msec width.

## ● Electrical and optical characteristics(Ta=25°C)

Parameter	Symbol	Condition	Min.	Typ.	Max.	Unit
Forward Voltage	$V_F$	$I_F=20mA$	-	3.5	4.0	V
Luminous Intensity	$I_v$	$I_F=20mA$	-	25000	-	mcd
Reverse Current	$I_R$	$V_R=5V$	-	-	100	$\mu A$
Peak Wave Length	$\lambda_p$	$I_F=20mA$	-	520	-	nm
Dominant Wave Length	$\lambda_d$	$I_F=20mA$	520		530	nm
Spectral Line Half-width	$\Delta \lambda$	$I_F=20mA$	-	30	-	nm
Viewing Angle	$2\theta_{1/2}$	$I_F=20mA$	-	12	-	deg

## ● Typical electro-optical characteristics curves

Fig.1 Relative intensity vs. Wavelength

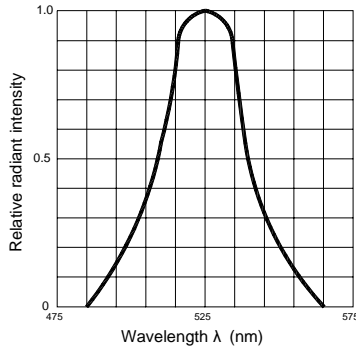

Fig.2 Forward current derating curve vs. Ambient temperature

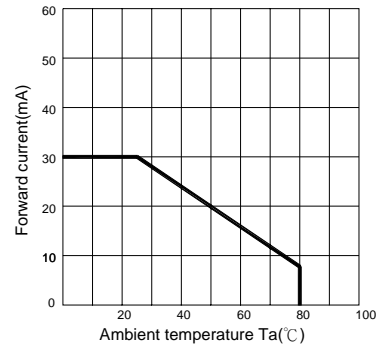

Fig.3 Forward current vs. Forward voltage

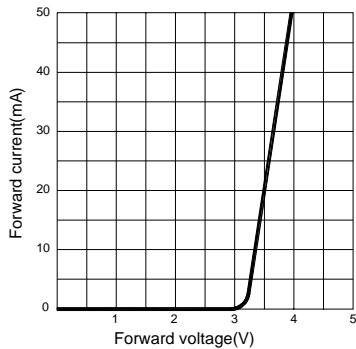

Fig.4 Relative luminous intensity vs. Ambient temperature

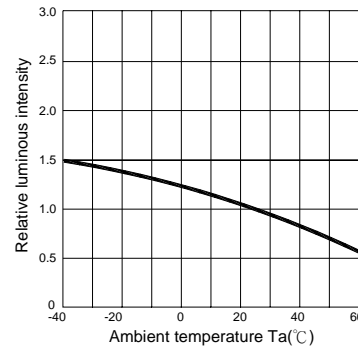

Fig.5 Relative luminous intensity vs. Forward current

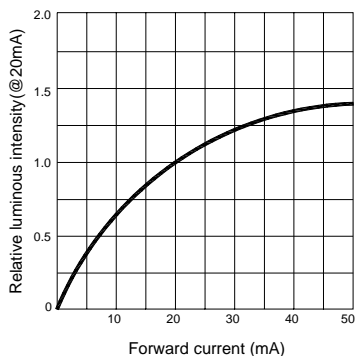
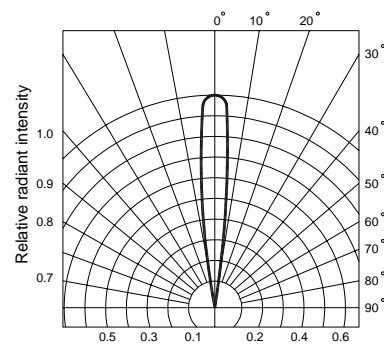

Fig.6 Radiation diagram



● **Bin Limits**

1. Intensity Bin Limits (At  $I_F=20\text{mA}$ )

Bin Code	Min. (mcd)	Max. (mcd)
ZB	8325	12488
ZC	12488	18731
ZD	18731	28097
ZE	28097	42145
ZF	42145	63218

2. Color Bin Limits (At  $I_F=20\text{mA}$ ) : Dominant Wave Length  $\lambda_d(\text{nm})$

Bin Code	Min. (nm)	Max. (nm)
6	520	525
7	525	530

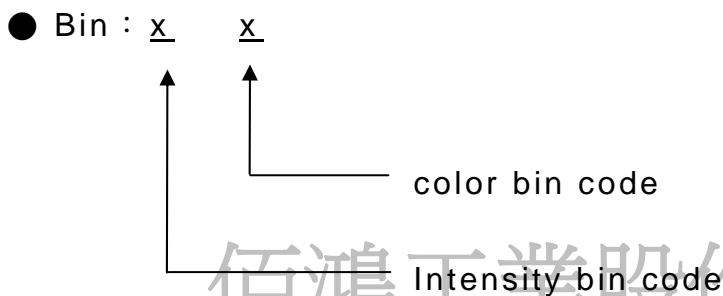

佰鴻工業股份有限公司

NOTES: 1. Tolerance of measurement of luminous intensity. :  $\pm 15\%$

2. Tolerance of measurement of dominant wavelength :  $\pm 1.0\text{nm}$

<http://www.brtled.com>