

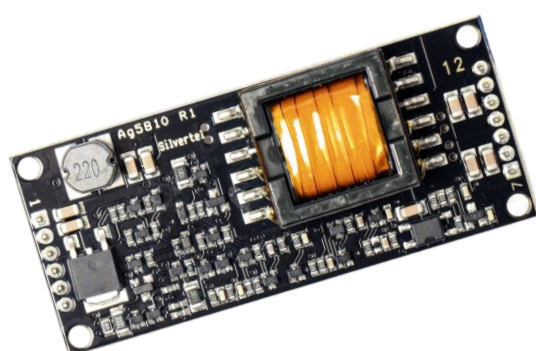

# Ag5810

60W IEEE802.3bt PD Module



## Features

- IEEE802.3bt Type 4 compliant
- 60 Watt Output Power
- Very small size
- High efficiency DC/DC converter
- 12V or 24V output adjustable
- 1500V isolation (input to output)
- Input voltage range 36V to 57V
- Low output ripple and noise
- Minimal (low cost) external components required
- Overload, thermal and short-circuit protection
- Silvertel "design-in" assistance
- Designed and manufactured in the UK

## Description

The Ag5810 is an IEEE802.3bt Type 4 Power over Ethernet module that can deliver up to 60 Watts of output power. Suitable for applications such as WiMAX access points, PTZ cameras, notebook computers, IP cameras, LED lighting, intelligent displays and thin client terminals.

The Ag5810 extracts power from an IEEE802.3bt Power Sourcing Equipment (PSE) over an Ethernet cable. Conforming to the IEEE802.3bt standard for signature recognition with class programming-fixed to class 7. It has been designed to work with IEEE802.3bt PSE's and existing high power PSE's from leading manufacturers.

The high efficiency DC/DC converter operates over a wide input voltage range and provides a regulated low ripple and low noise output. The DC/DC converter also has built-in overload, thermal and short-circuit output protection.

## Table of Contents

1	Product Overview .....	3
1.1	Ag5810 Product Selector .....	3
1.2	Pin Description .....	4
2	Functional Description .....	5
2.1	Overview.....	5
2.2	Power Supply .....	5
2.3	Input.....	6
2.3.1	PD Signature.....	6
2.3.2	Power Classification.....	6
2.3.3	PSE Type Detection.....	7
2.4	Output.....	8
2.4.1	DC/DC Converter .....	8
2.4.2	Output Configuration .....	8
2.4.3	Output Adjustment .....	9
2.4.4	Output Power .....	10
2.5	Typical Connections .....	10
2.6	High Power Applications .....	11
2.7	Additional Output Filtering.....	12
3	Operating Temperature Range .....	13
3.1	PCB Thermal Layout.....	15
3.2	Heat Sink Assembly .....	16
4	Isolation.....	17
5	Protection .....	18
6	EMC .....	18
7	Electrical Characteristics.....	19
7.1	Absolute Maximum Ratings.....	19
7.2	Recommended Operating Conditions .....	19
7.3	DC Electrical Characteristics.....	20
8	Package .....	21

## Table of Figures

Figure 1: Block Diagram .....	3
Figure 2: Ag5810 Package Format.....	3
Figure 3: Typical System Diagram .....	5
Figure 4: Physical Layer Detect Configuration .....	7
Figure 5: Output Configurations .....	8
Figure 6: Output Adjustment.....	9
Figure 7: Typical Connection Diagram .....	10
Figure 8: High Power configuration .....	11
Figure 9: Additional Output Filtering .....	12
Figure 10: Operating Temperature .....	13
Figure 11: Operating Temperature (Thermally connected to PCB) .....	14
Figure 12: Suggested Heatpad Footprint .....	15
Figure 13: Suggested Heat Sink Assembly .....	16
Figure 14: Position of the Isolation Barrier .....	17
Figure 15: EMC Filtering.....	18
Figure 16: Package Dimensions.....	21

# 1 Product Overview

## 1.1 Ag5810 Product Selector

Part Number <sup>1</sup>	Nominal Output Voltage <sup>2</sup>	Maximum Output Power <sup>3</sup>
Ag5810	12V / 24V	60W

Note 1: Complies with the European Directive 2011/65/EU for the Restriction of use of certain Hazardous Substances (RoHS) including Directive 2015/863 published in 2015, amending Annex II of Directive 2011/65/EU. Moisture Sensitive Level 1 and HBM 1.

Note 2: Voltage depending on output configuration (Parallel or Series), see Section 2.4.2.

Note 3: At 25°C must include adequate thermal management

**Table 1: Ordering Information**

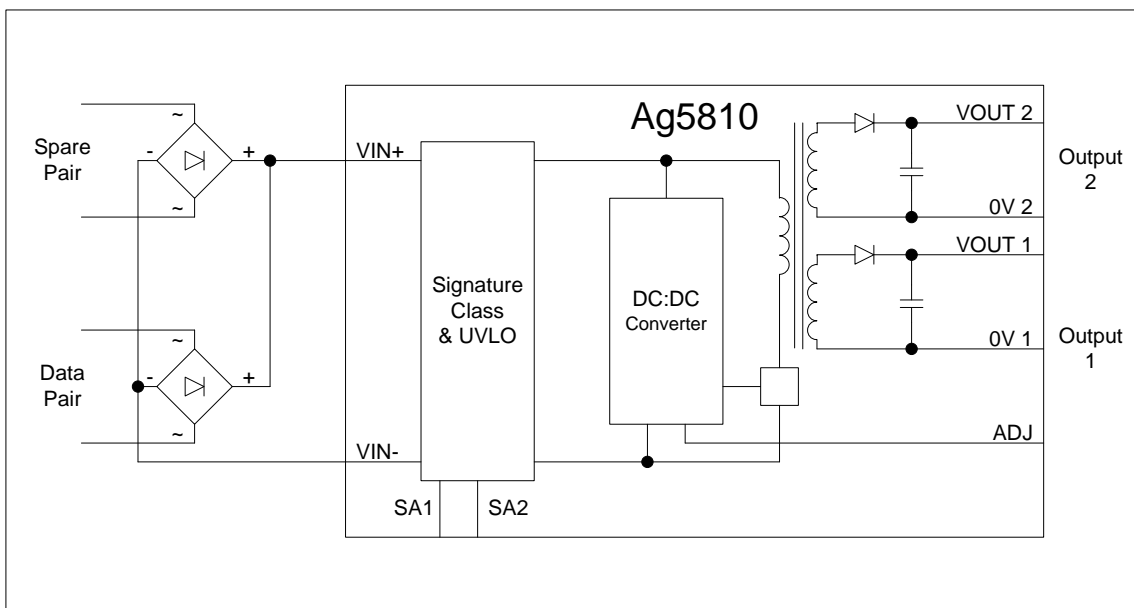

**Figure 1: Block Diagram**



**Figure 2: Ag5810 Package Format**

## 1.2 Pin Description

### Input Connector Pins

Pin #	Name	Description
1	VIN+	<b>Direct Input +</b> This pin connects to the positive (+) output of the input bridge rectifier.
2	VIN-	<b>Direct Input -</b> This pin connects to the negative (-) output of the input bridge rectifier.
3	TYP 2-Det	<b>Type 2 IEEE802.3at Detect Output</b> This pin indicates if a Type 2 IEEE802.3at PSE is supplying power; see Section 2.3.3 for more details.
4	TYP 4-Det	<b>Type 4 IEEE802.3bt Detect Output</b> This pin indicates if a Type 4 IEEE802.3bt PSE is supplying power to both inputs; see Section 2.3.3 for more details.
5	SA1	<b>Signature resistance adjustment</b> (see section 2.3.1)
6	SA2	<b>Signature resistance adjustment</b> (see section 2.3.1)

### Output Connector Pins

Pin #	Name	Description
7 & 8	VOUT1	<b>DC Output</b> This pin provides the main regulated output from the DC/DC converter.
9	0V1	<b>Ground</b> The ground return for the VOUT1 output.
10	VOUT2	<b>DC Output</b> This pin provides the secondary output from the DC/DC converter.
11 & 12	0V2	<b>Ground</b> The ground return for the VOUT2 output.
13	ADJ	<b>Output Adjust</b> The output voltage can be adjusted from its nominal value, by connecting an external resistor from this pin to either the VOUT1 pin or the 0V1 pin.

## 2 Functional Description

### 2.1 Overview

The Ag5810 has a single input that can be connected to two external bridge rectifiers (see Figure 1: Block Diagram). This allows the Ag5810 to be compatible with equipment that uses the different power options. The Ag5810 was developed to be powered with the Silvertel Ag6800 or Ag6130 PSE along with other leading manufacturers of IEEE802.3bt compliant PSEs. It can also be used with other high Power PSE's i.e. UPoE PSE's and Phihong's legacy 12.5K signature PSEs with the setup explained in section 2.3.1 and 2.3.2.

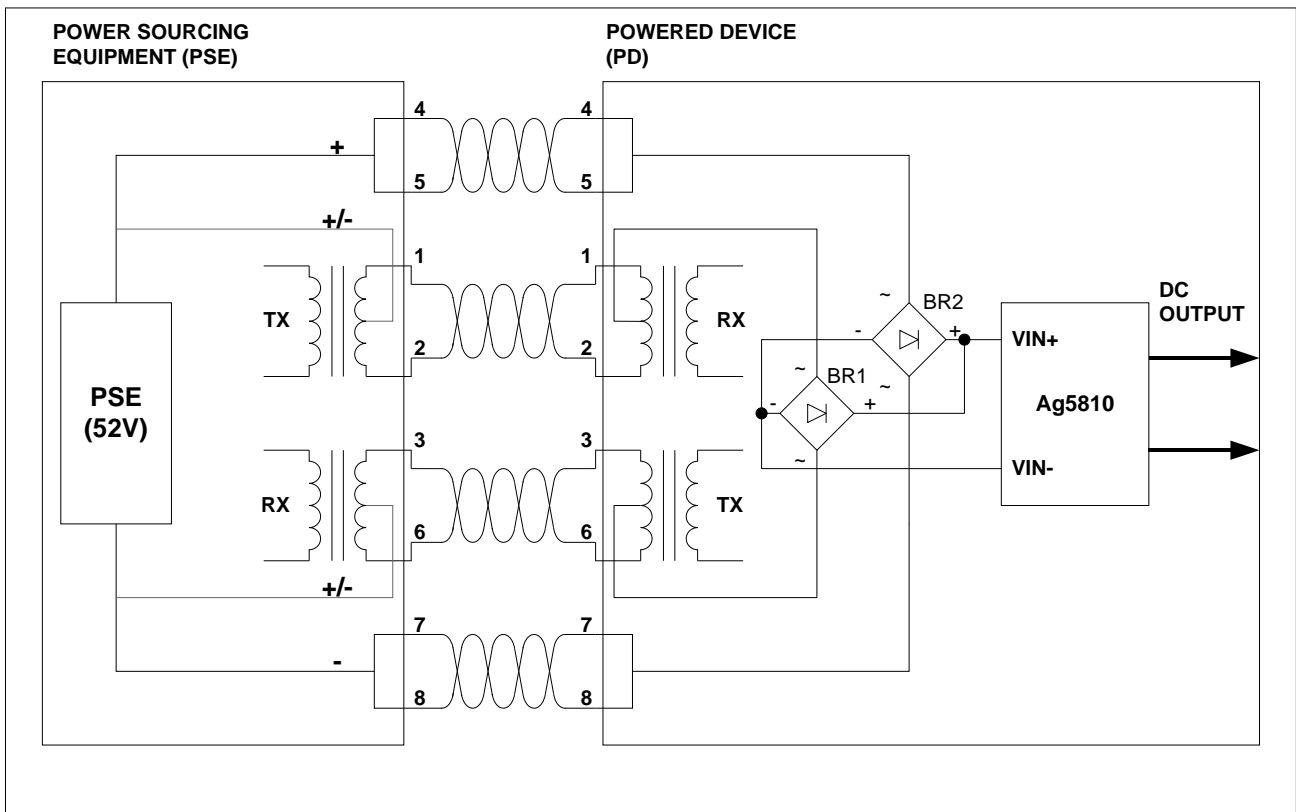

**Figure 3: Typical System Diagram**

### 2.2 Power Supply

The Ag5810 is a Class 7 Type 4 IEEE802.3bt Powered Device and as such should be powered with the appropriate power supply, this being either an IEEE802.3bt compliant PSE or a DC power supply with a minimum power specification of 52V at 2A. This minimum rating power supply must be chosen regardless of the customers load as the inrush and power limits of the Ag5810 are designed to provide 60W out. If the customer is designing their own PSE to use with the Ag5810 they must also ensure that the power supply to the PSE is capable of this minimum power capability.

## 2.3 Input

### 2.3.1 PD Signature

The input complies with the IEEE802.3bt specification and provides signature and control circuitry to give full backwards PoE standards compatibility. When the inputs are connected to a Power Sourcing Equipment (PSE), they will automatically present a Powered Device (PD) signature to the PSE (when requested). The equipment will then recognise that a PD is connected to that line and supply power.

Note: The SA1 and SA2 pins must be connected together when used with a Pihong POE80U or POE60U PSE. For all other PSE's these pins should be left unconnected.

### 2.3.2 Power Classification

The Ag5810 is Type 4 - Class 7 PD requesting 75 watts of power from an IEEE802.3bt PSE by displaying the correct class pulses shown in Table 2 below. If the Ag5810 is connected to an IEEE802.3at PSE, the PSE will recognise the initial Class 4 pulse from the Ag5810 as a Type 2 PD and provide ~25W.

Requested Class	Class Pulse Count	Pulse 1&2 Classification Current (mA)	Pulse 3+ Classification Current (mA)	PSE Output Power (W)	Min. Available PD Power (W)	IEEE Spec. Amendment
0	1	<5	N/A	15.4	12.75	802.3af
1	1	10	N/A	4	3.84	
2	1	20	N/A	7	6.49	
3	1	30	N/A	15.4	12.75	
4	2 or 3	40	40	30	25.5	802.3at
5	4	40	<5	45	40	802.3bt
6	4	40	10	60	51	
7	5	40	20	75	62	
8	5	40	30	90	71.3	

**Table 2: Classification Table**

### 2.3.3 PSE Type Detection

The Ag5810 has two output detection pins which are used to identify whether a Type 2 or 4 PSE is connected to its input such that communication can be sent over the Physical Layer as described in the IEEE802.3bt specification. The TYP2 or TYP4 pin can be connected directly to an opto-coupler such that the output can cross the isolation barrier, as shown in Figure 4.

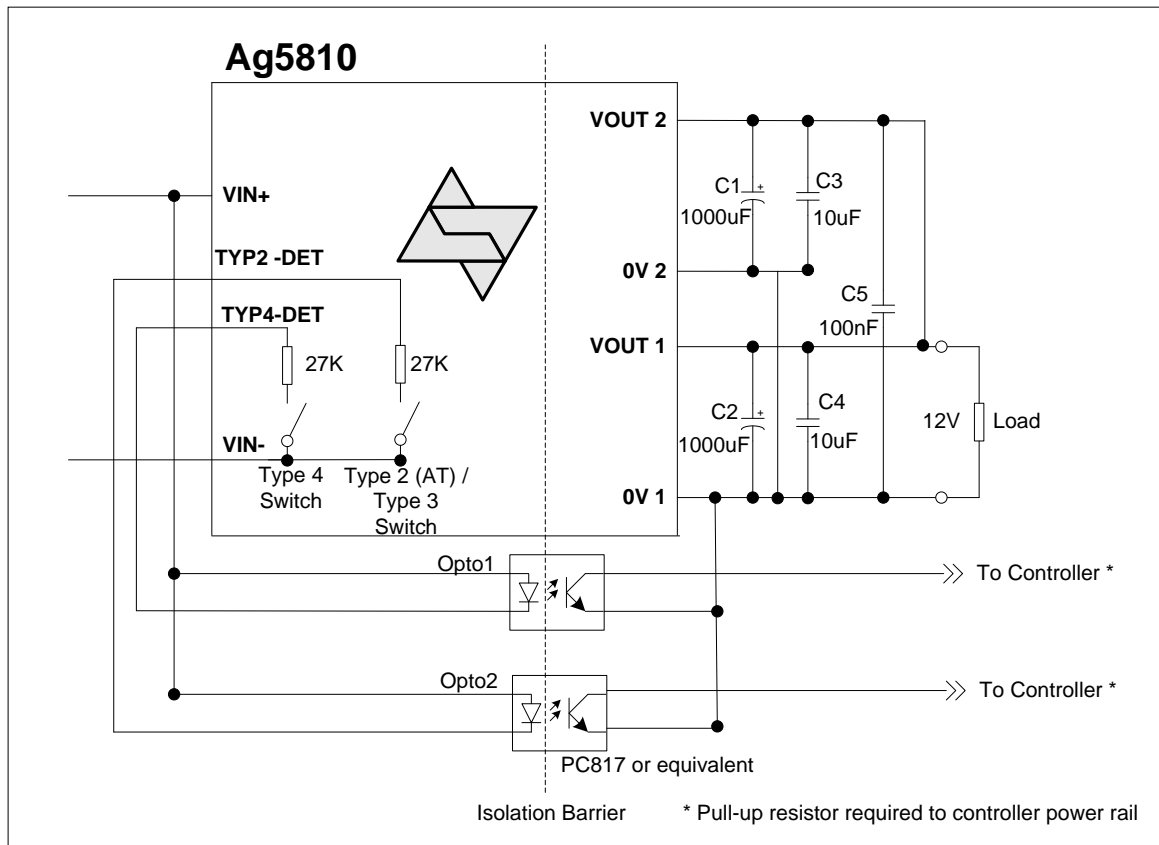

**Figure 4: Physical Layer Detect Configuration**

If for example the Ag5810 detects a Type 4 Event on the Physical Layer classification, the (TYP4) switch will close and Opto1 will turn ON. Opto1 will pass this signal across the isolation barrier and the output collector can be connected to a controller (with a pull-up resistor connected to the controller's power rail). When Opto1 is ON the collector (output) will be Logic 0, the controller will then know that the PSE is capable of delivering the required power and should then confirm that it is a Type 4 PD over the Data Link Layer\*. The same method will be applied to the TYP2 connection with Opto 2 turning on when connected to a Type 2.

\*Note: If the connected PSE does not support the Data Link Layer (DLL) Opto 1&2 do not need to be fitted and the Ag5810 will still draw the maximum power available from the PSE.

## 2.4 Output

### 2.4.1 DC/DC Converter

The Ag5810's DC/DC converter provides a regulated low ripple and low noise output that has built-in output over-load and short-circuit protection.

### 2.4.2 Output Configuration

The Ag5810 has two outputs which must be connected either in parallel to provide 12V or in series to provide 24V, as shown in Figure 5: Output Configurations.

Output 2 voltage (VOUT2) tracks the output 1 voltage (VOUT1). The use of the two outputs separately is not recommended due to voltage regulation issues.

It is important that C1, C3 and C2, C4 are both used and connected as close to the output pins of the Ag5810 as possible (for both configurations).

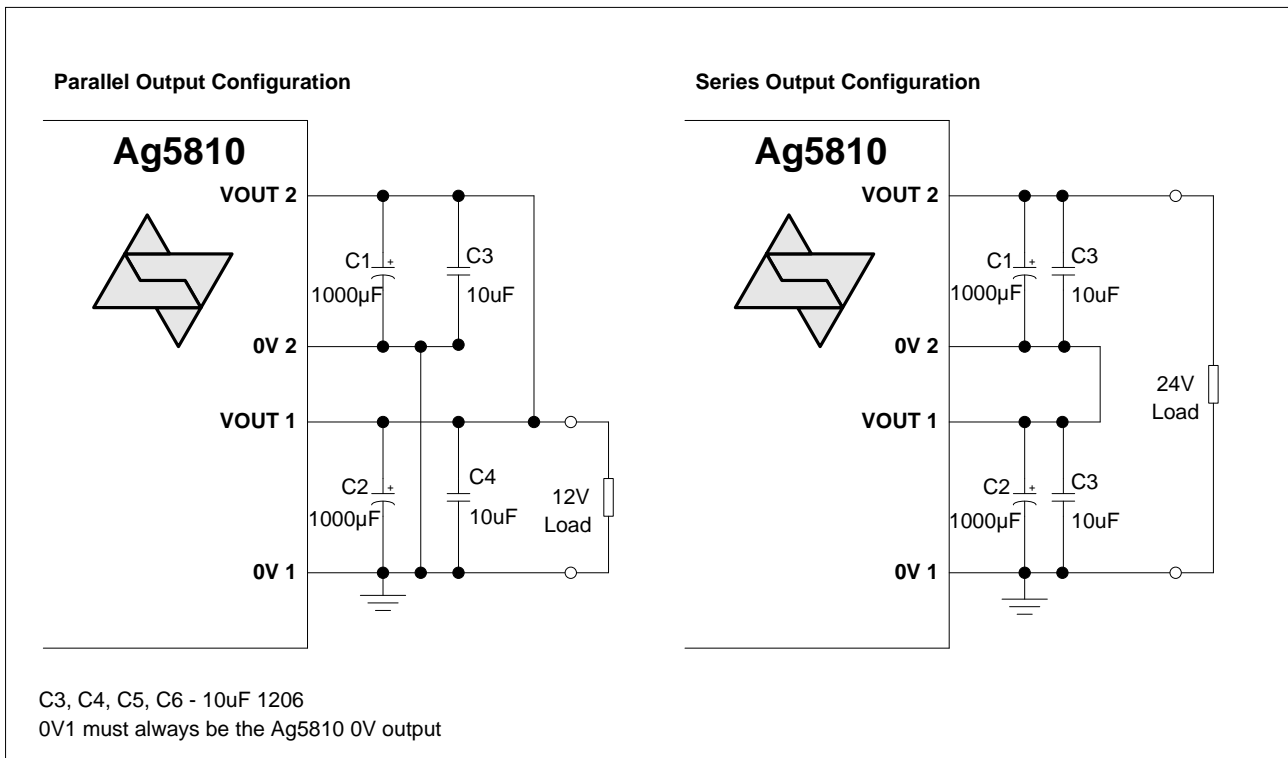

**Figure 5: Output Configurations**



### 2.4.3 Output Adjustment

The Ag5810 has an ADJ pin, which allows the output voltage to be increased or decreased from its nominal value.

The adjustment range allows the Ag5810 to provide an output voltage from 10.55V up to 30.4V. Voltage must not be adjusted to less than 10.5V or permanent damage may be caused. Contact Silvertel for further details.

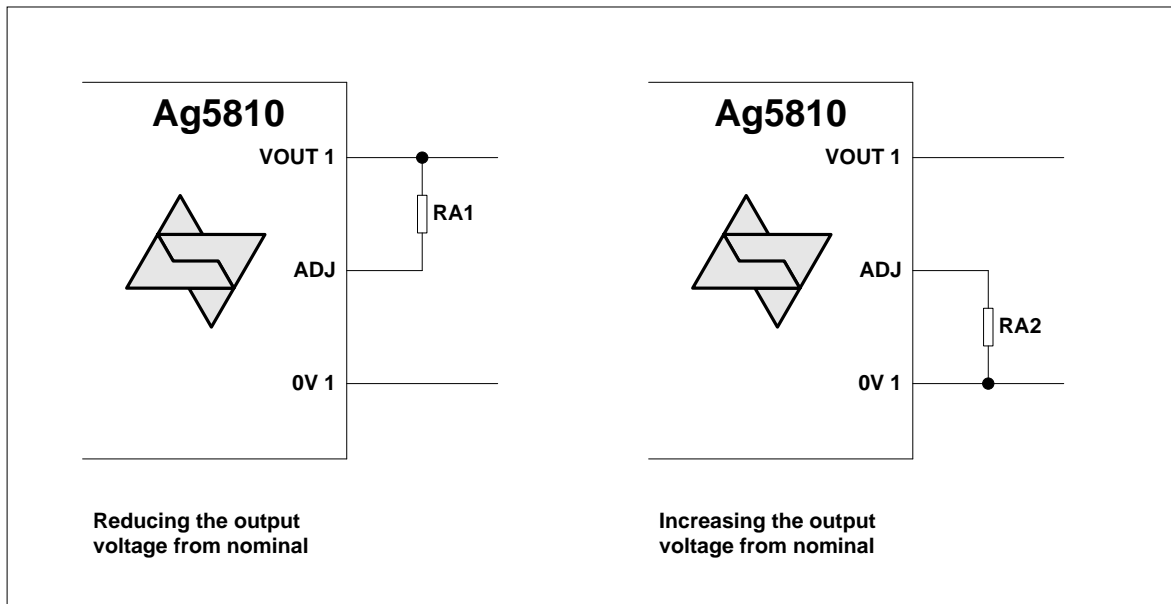

**Figure 6: Output Adjustment**

Reducing the output voltage, connect R between ADJ and VOUT 1		
Value of RA1	VOUT Parallel	VOUT Series
Open Circuit	12V	24V
91K *	10.55V	21.1V

Increasing the output voltage, connect R between ADJ and 0V 1		
Value of RA2	VOUT Parallel	VOUT Series
Open Circuit	12V	24V
8K2	15V	30.2V

\* RA1 must not be less than 91K. Adjusting Vout to less than 10.5V may cause permanent damage

**Table 3: Output Adjustment Resistor (R) Value**

### 2.4.4 Output Power

The maximum output power of the Ag5810 is 60W\*; however this is limited by the available input power to the module.

When calculating the output power, the following factors must be taken into account: -

- Ag5810 efficiency
- PSE output power
- Cable and connector losses
- Input bridge rectifier losses

\* When the output voltage is adjusted to its maximum the power must be limited to 60W. e.g. with Vout set to 30V the output current must be reduced to 2A.

### 2.5 Typical Connections

As shown in Figure 7 Typical Connection Diagram, a minimum of 1000µF must be connected across each output, positioned as close to the output pins as possible. These capacitors are needed for output filtering and step load change performance and can be a standard low cost electrolytic; they do not need to be a low ESR type.

The Class programming, Output Adjust inputs and Signature inputs are optional and are provided to give greater flexibility to the Ag5810. Further information on using these inputs can be found in sections 2.3.2 Power Classification and 2.4.3 Output Adjustment.

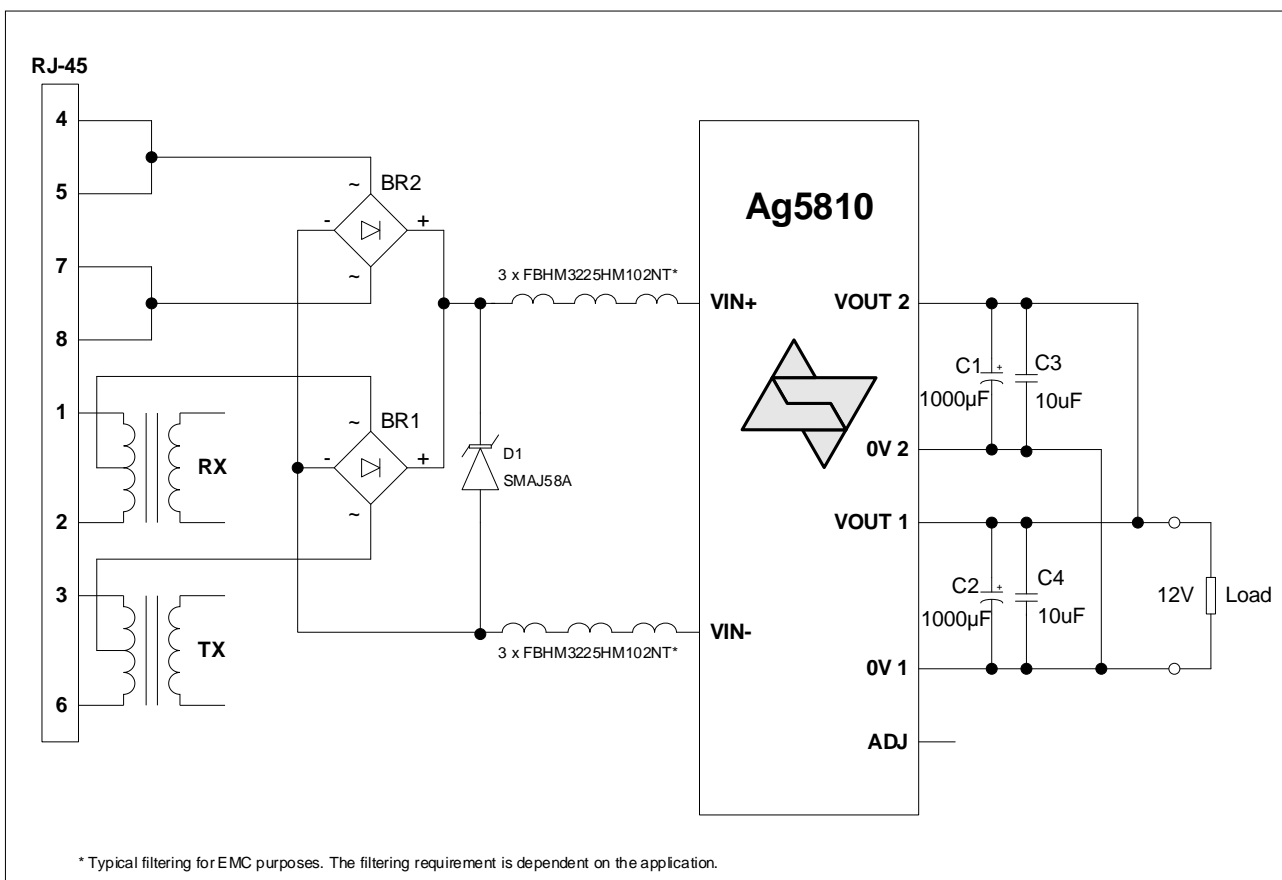

**Figure 7: Typical Connection Diagram**

## 2.6 High Power Applications

Figure 8 shows typical application diagrams for the Ag5810 connected to the Ag6800 PSE.

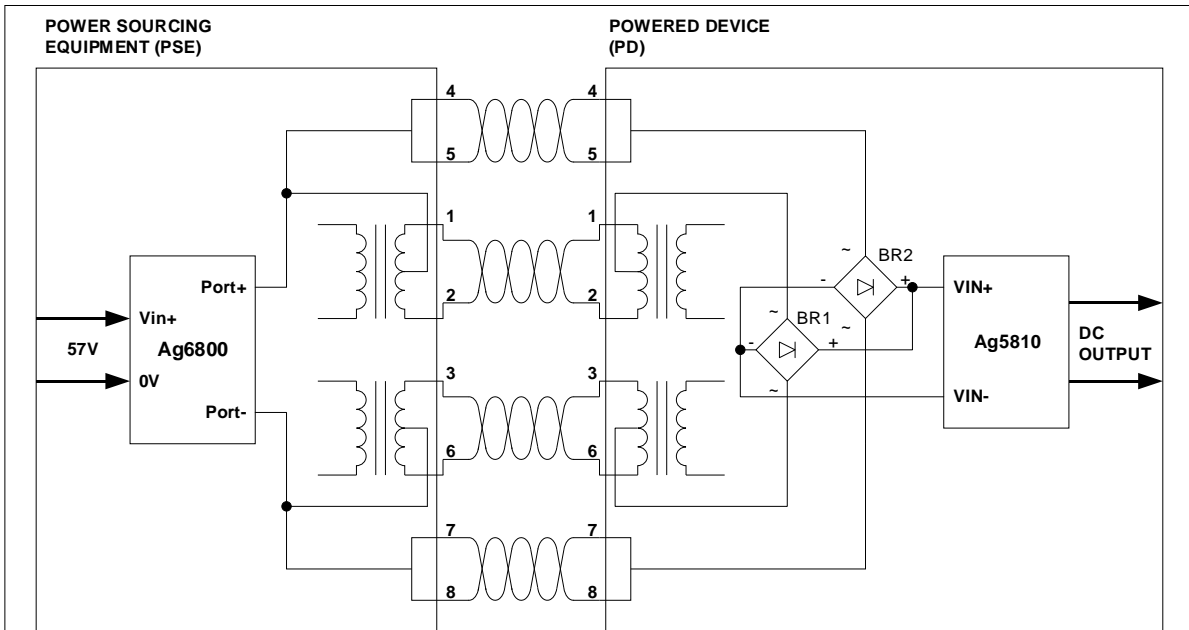

Figure 8a – Typical Application Diagram for Ag6800 using 10/100BASE-T

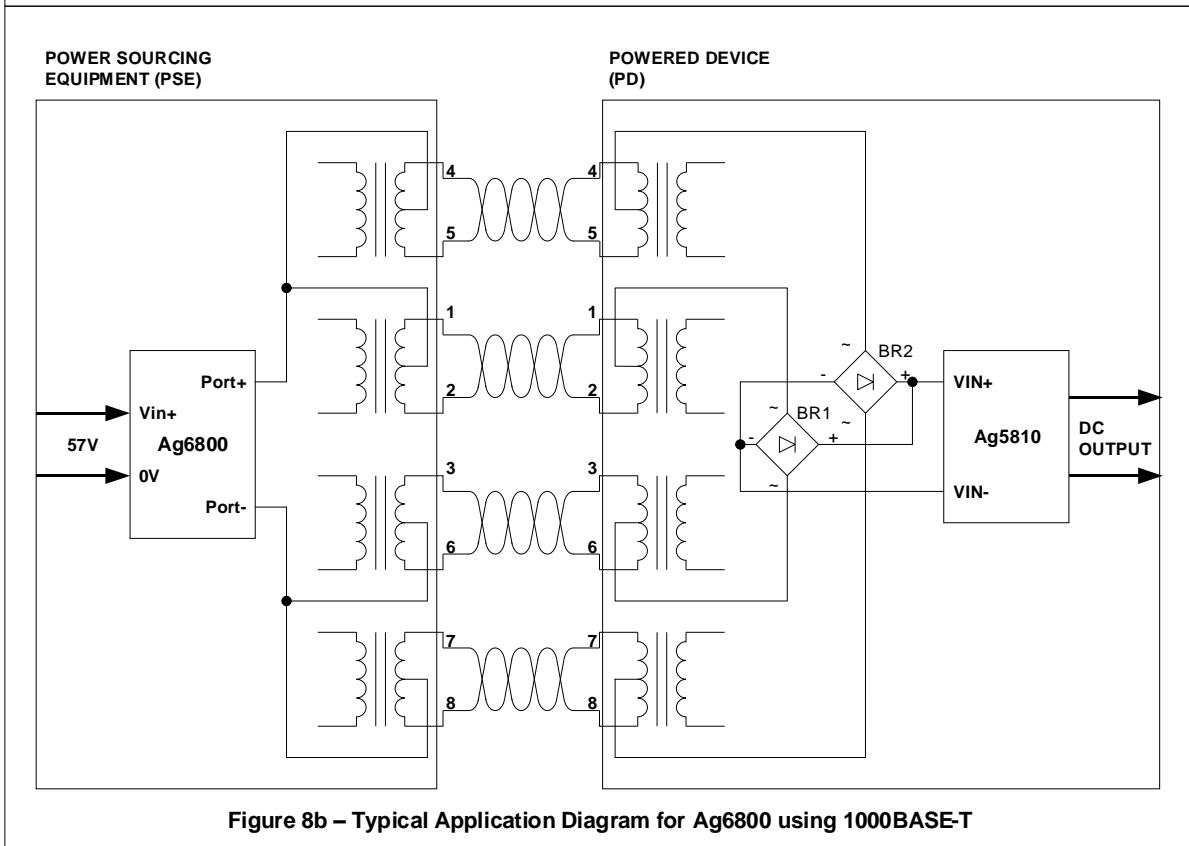
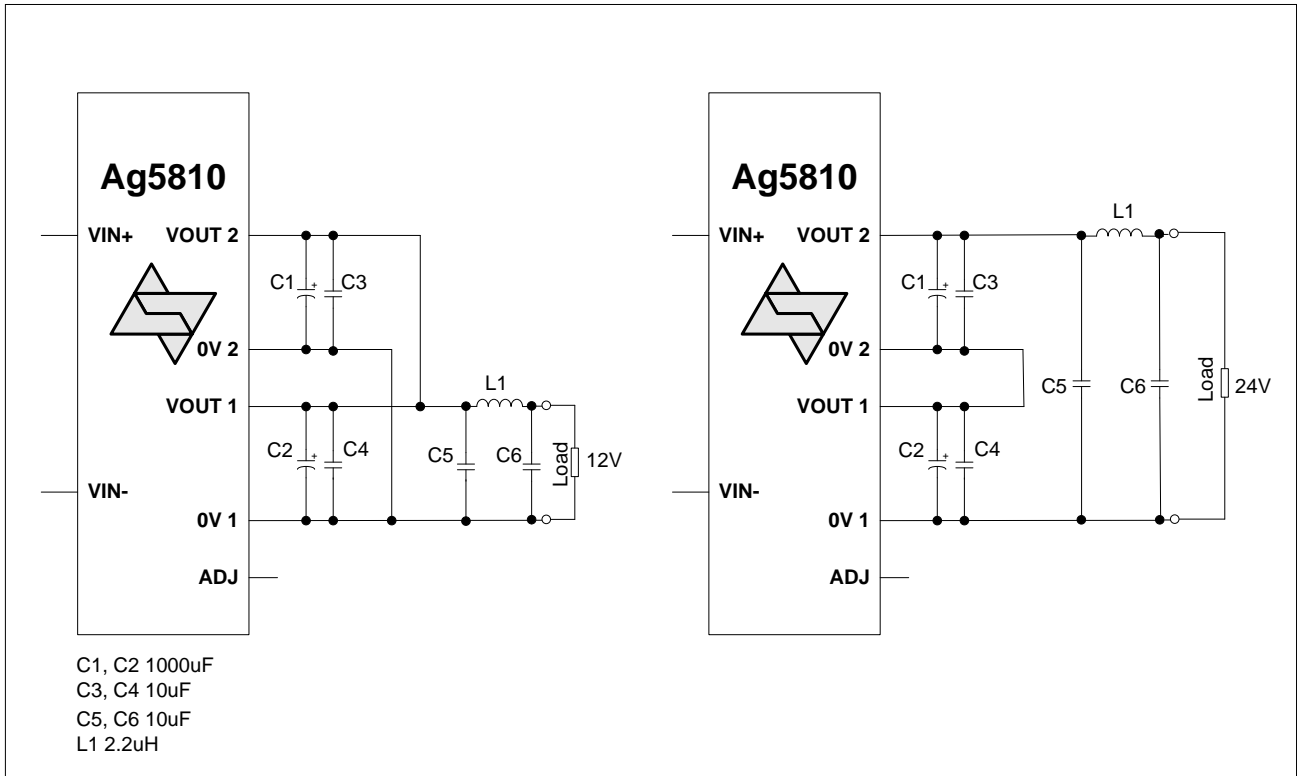

Figure 8b – Typical Application Diagram for Ag6800 using 1000BASE-T

**Figure 8: High Power configuration**

## 2.7 Additional Output Filtering

The Ag5810 output ripple and noise can be reduced by adding an additional output filter. Figure 9 shows a cost effective method which can reduce the output ripple when configured in series or parallel.



**Figure 9: Additional Output Filtering**

### 3 Operating Temperature Range

It is important to remember that Ag5810 is a power supply, and as such careful consideration should be taken over the mechanical design of the host product, with provision for heat sinking and/or forced air cooling.

At full power the Ag5810 will generate heat. The device has been designed to be used with a heatsink which thermally connects to the Ag5810 through the use of thermal pad such as Bergquist .1" Ultra soft gap pad or thermal paste such as Thermally conductive Oxime Cure paste. The customers PCB can then be thermally mounted (using a Bergquist 0.1" Ultra soft gap pad) to the chassis of the host equipment. Further thermal relief can be in the form of cooled or forced air improving the power output.

Because each application is different it is impossible to give fixed and absolute thermal recommendations. However to obtain maximum power it is important that any enclosure used has sufficient ventilation and airflow over the Ag5810.

Figure 10 shows the maximum ambient temperature under continuous load conditions. The Ag5810 is capable of handling 60W up to 70°C only when mounted to a heatsink. A suggested mounting method is shown in Figure 13.

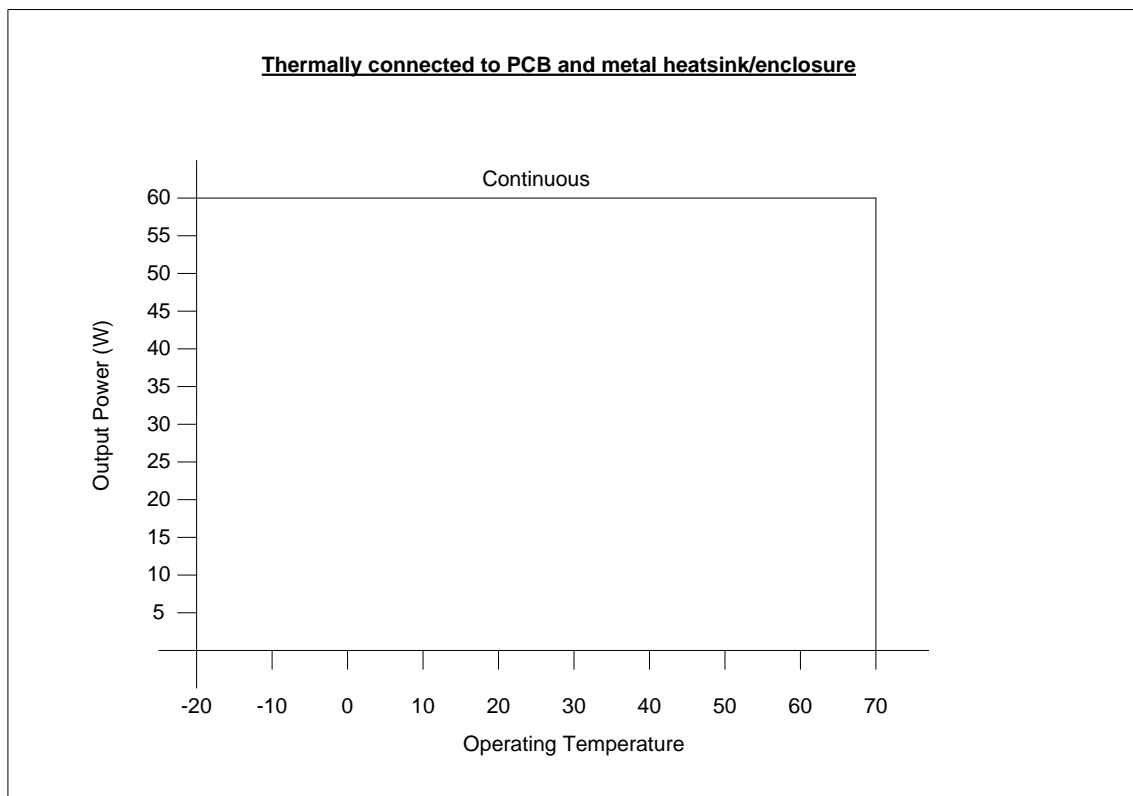

**Figure 10: Operating Temperature**

If the Ag5810 is thermally connected to the PCB only, without an additional heatsinking, then 60W can only be obtained up to 50°C. Suggested layout and dimensions of the thermal relief pads can be found in Figure 12 respectively.

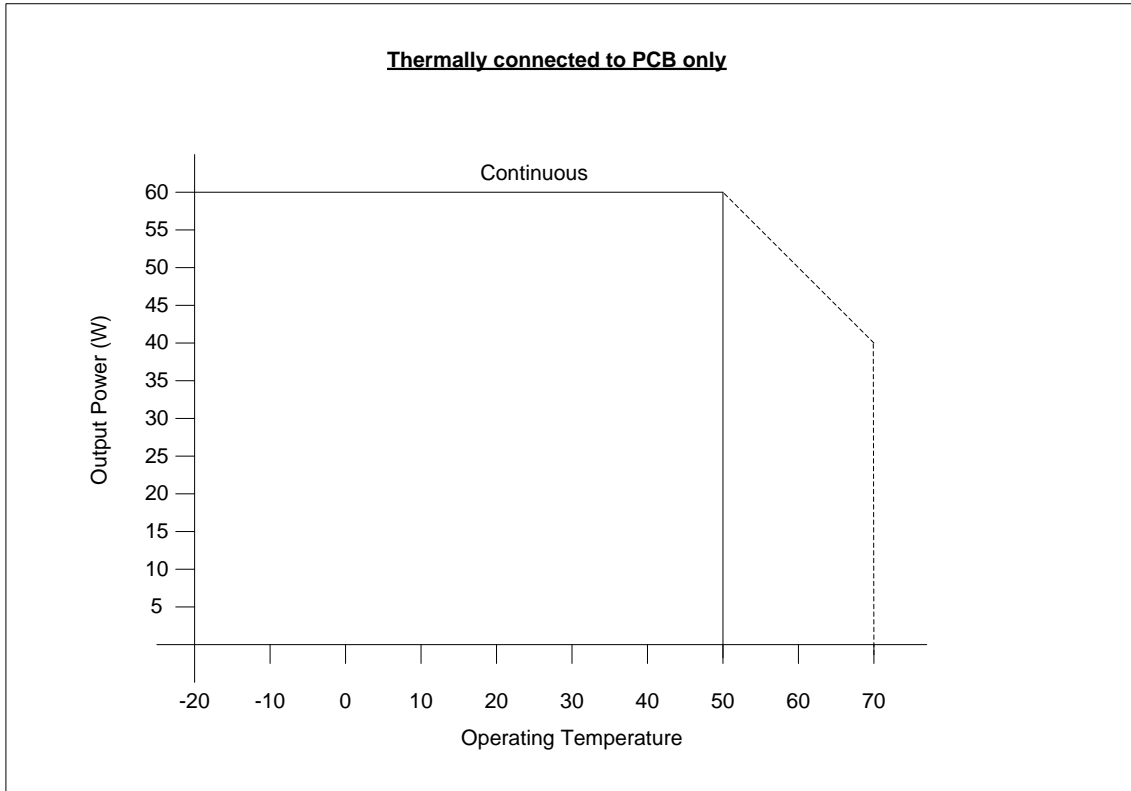

**Figure 11: Operating Temperature (Thermally connected to PCB)**

When intended for use in ambient temperatures below 0°C we would recommend a low ESR electrolytic capacitor be used on the DC output. Capacitors rated for -55°C operation should be used below 0°C.

### 3.1 PCB Thermal Layout

To attain continuous operation at 60W the Ag5810 must be thermally connected to the customers PCB and their enclosure or heatsink. The thermal layout should have copper pads with a via array to help draw the heat through the PCB to the heatsink. An example of a thermal layout can be found below with dimensions shown in Figure 12.

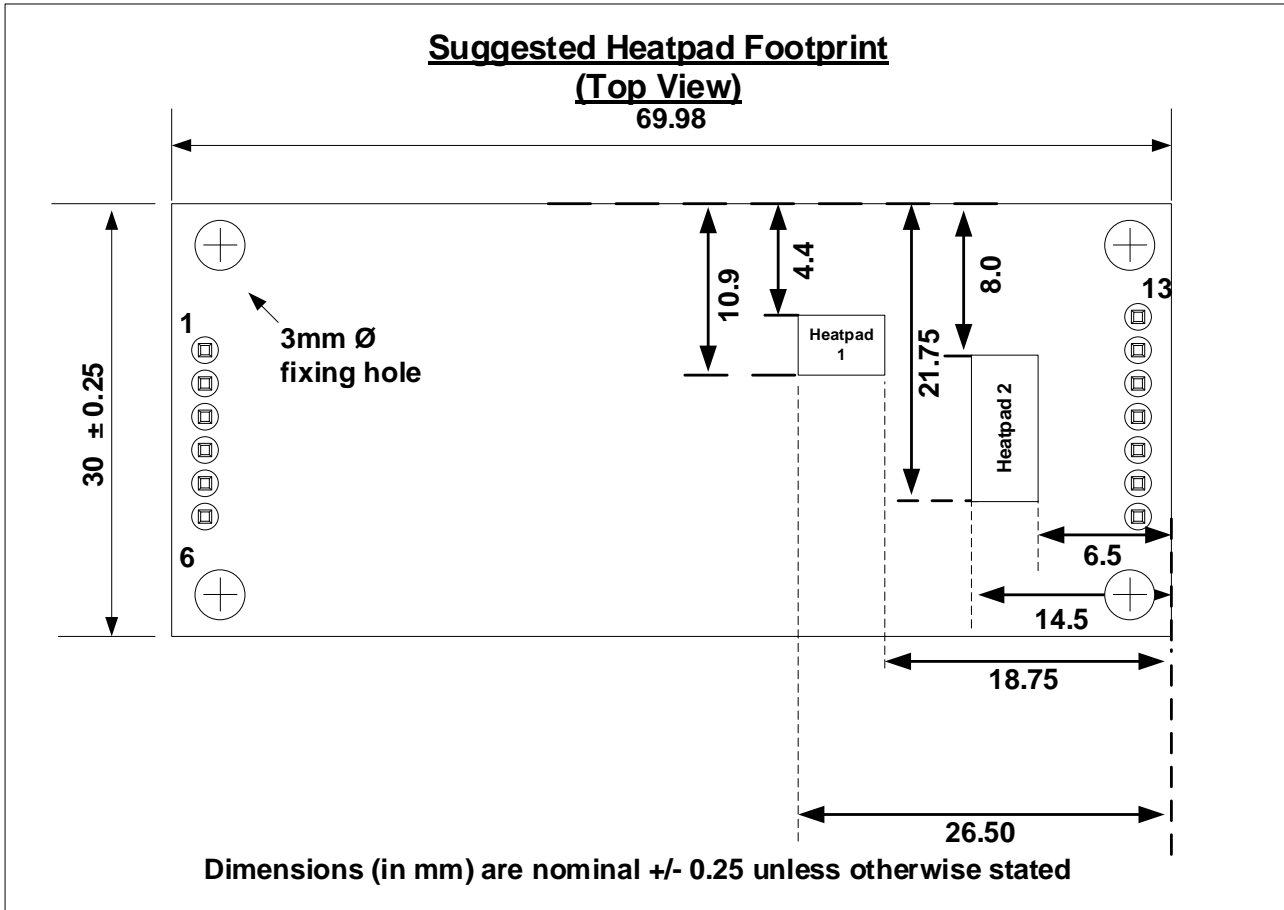
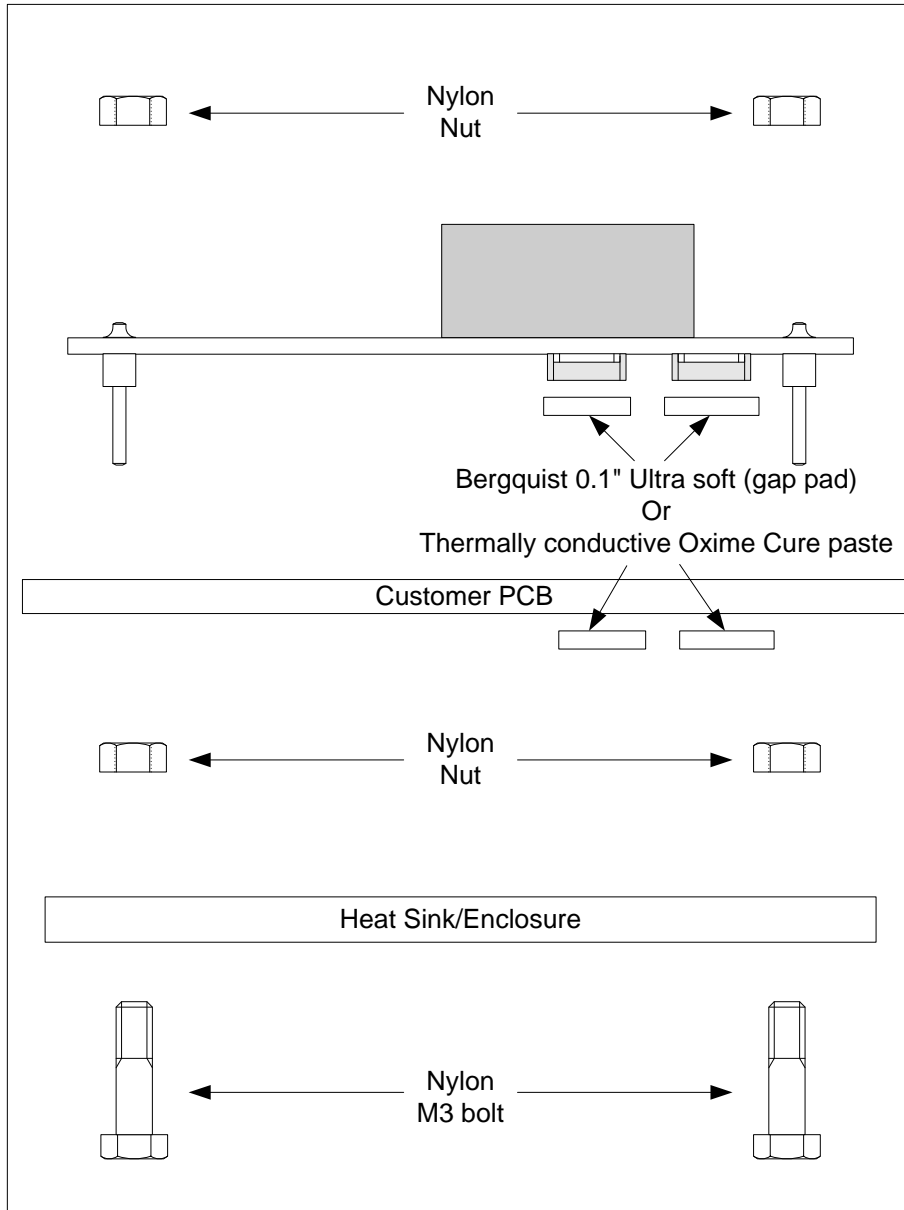

Figure 12: Suggested Heatpad Footprint

### 3.2 Heat Sink Assembly



**Figure 13: Suggested Heat Sink Assembly**



## 4 Isolation

To meet the isolation requirements of IEEE802.3bt section 145.4.1 a Powered Device (PD) must pass the electrical strength test of IEC 60950 sub clause 6.2. This calls for either a) 1500VAC test or b) 1500V impulse test. The Ag5810 has been designed to meet b) 1500V impulse test. When mounting the module to the heat sink, you must ensure a clearance of 1.5mm minimum between the pins of the connectors and the heat sink or use some form of isolation such as at least two layers of 3M#56 insulating tape.

Figure 14 shows the position of the isolation barrier on the bottom of the Ag5810.

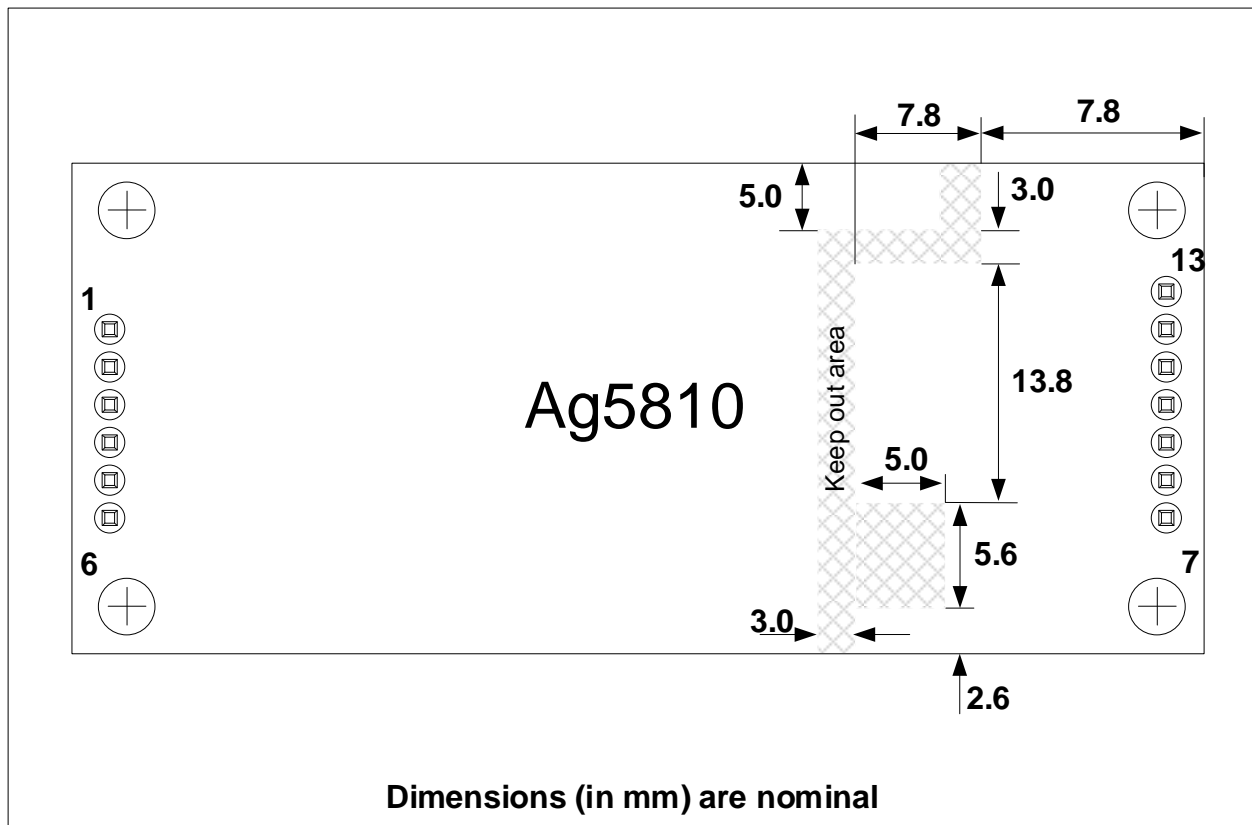

Figure 14: Position of the Isolation Barrier

## 5 Protection

The Ag5810 must be protected from over-voltages exceeding the 80V maximum rated surge input voltage. An inexpensive but effective solution can be achieved by connecting a Tranzorb diode across the input; see Apps Note “ANX-POE-Protection”.

## 6 EMC

The Ag5810 has been designed to pass EN55032 Class B, however the Ag5810 will only be one component within a system so we would always advise that provisions are put in place in case further noise reductions are needed. From our extensive experience we recommend the inexpensive but effective solution to reduce emissions shown in Figure 15.

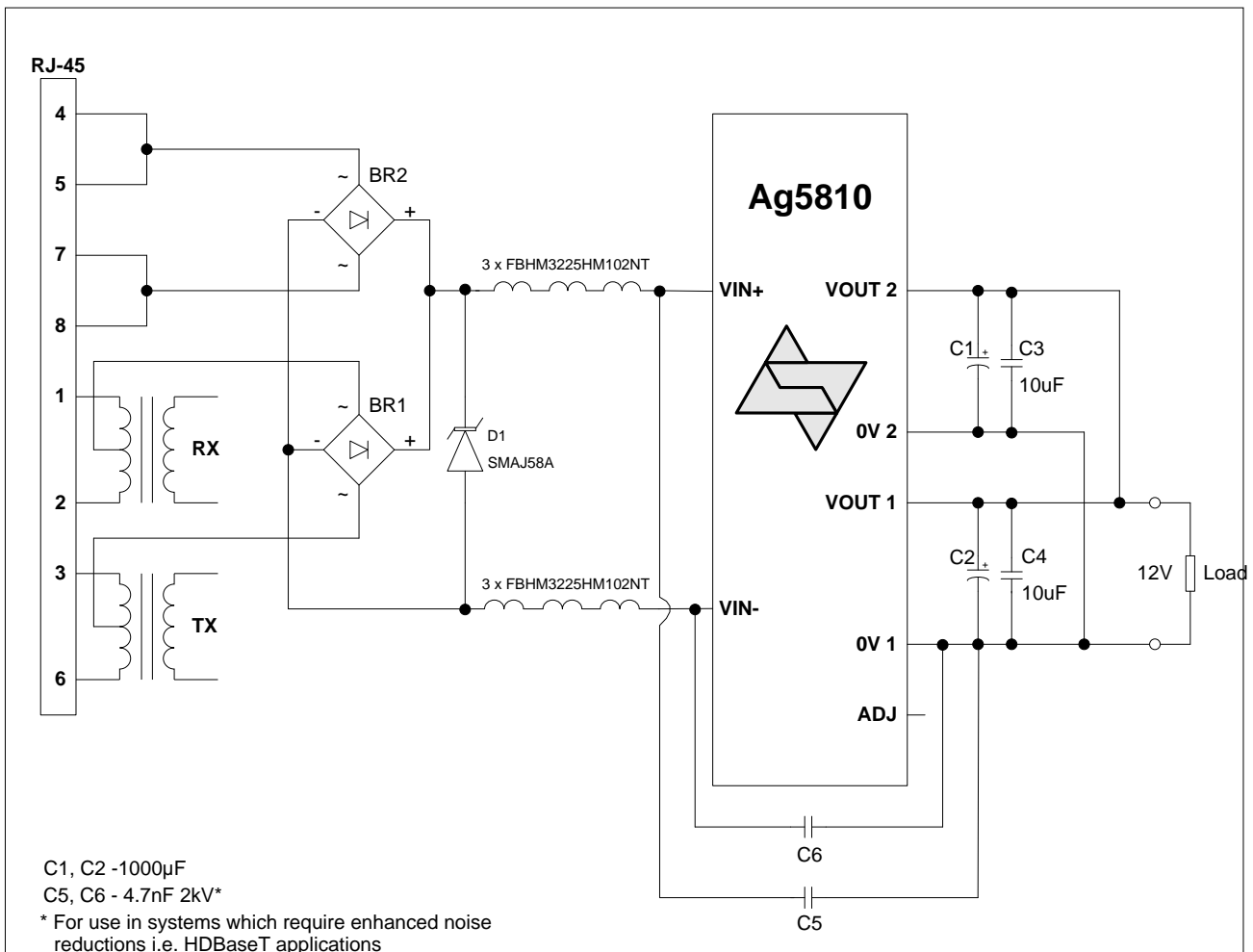

**Figure 15: EMC Filtering**

## 7 Electrical Characteristics

### 7.1 Absolute Maximum Ratings

	Parameter	Symbol	Min	Max	Units
1	DC Supply Voltage	$V_{CC}$	-0.3	60	V
2	DC Supply Voltage Surge for 1ms	$V_{SURGE}$	-0.6	80	V
3	Storage Temperature	$T_S$	-40	+100	°C

Note: Exceeding the above ratings may cause permanent damage to the product. Functional operation under these conditions is not implied. Maximum ratings assume free airflow.

### 7.2 Recommended Operating Conditions

	Parameter	Symbol	Min	Typ	Max	Units
1	Supply Voltage <sup>1</sup>	$V_{IN}$	60W Output	52	57	V
			≤25.5W load	40	57	
2	Transient Supply Voltage <sup>2</sup>		36			V
3	Under Voltage Lockout	$V_{LOCK}$	30		36	V
4	Operating Temperature <sup>3</sup>	$T_{OP}$	-30	25	70	$T_a$ / °C

Note 1: Output power limited by PSE current limit

Note 2: For transient events lasting between 30μs to 250μs, as detailed in the IEEE802.3 specification

Note 3: See Section 3 Operating Temperature Range

### 7.3 DC Electrical Characteristics

	DC Characteristic	Sym	Min	Typ <sup>1</sup>	Max	Units	Test Comments
1	Nominal Output Voltage	+VDC	11.4 22.8	12 24	12.6 25.2	V V	Parallel O/P Series O/P
2	Voltage Adjust Range	V <sub>ADJ</sub>	10.55		30.2	V	See 2.4.3 Output Adjustment
3	Continuous Output Current <sup>2</sup> V <sub>IN</sub> = 52V Min, V <sub>out</sub> = 24V max	I <sub>CONT</sub>			5.0 2.5	A A	Parallel O/P Series O/P
4	Line Regulation	V <sub>LINE</sub>		0.1		%	
5	Load Regulation	V <sub>LOAD</sub>		0.1		%	
6	Output Ripple and Noise <sup>3</sup> Parallel O/P (12v) Series O/P (24v)	V <sub>RN</sub>		15.6 40		mVp-p mVp-p	
7	Minimum Load <sup>4</sup>	I <sub>MIN</sub>	0			mA	
8	Short-Circuit Duration	T <sub>SC</sub>			∞	sec	
9	Efficiency	Eff		88		%	V <sub>in</sub> = 52V @1.8A Load
10	Isolation Voltage (I/O)	V <sub>ISO</sub>			150 0	V <sub>PK</sub>	Impulse Test

Note 1: Typical figures are at 25°C with a nominal 56V supply, parallel output configuration (unless otherwise stated) and are for design aid only. Not Guaranteed

Note 2: The output must not exceed 60W or 5.0A Parallel / 2.5A Series.

Note 3: The output ripple and noise was measured using the Pi Filter shown in figure 10.

Note 4: The Ag5810 has been designed to work normally when no load is connected.

## 8 Package

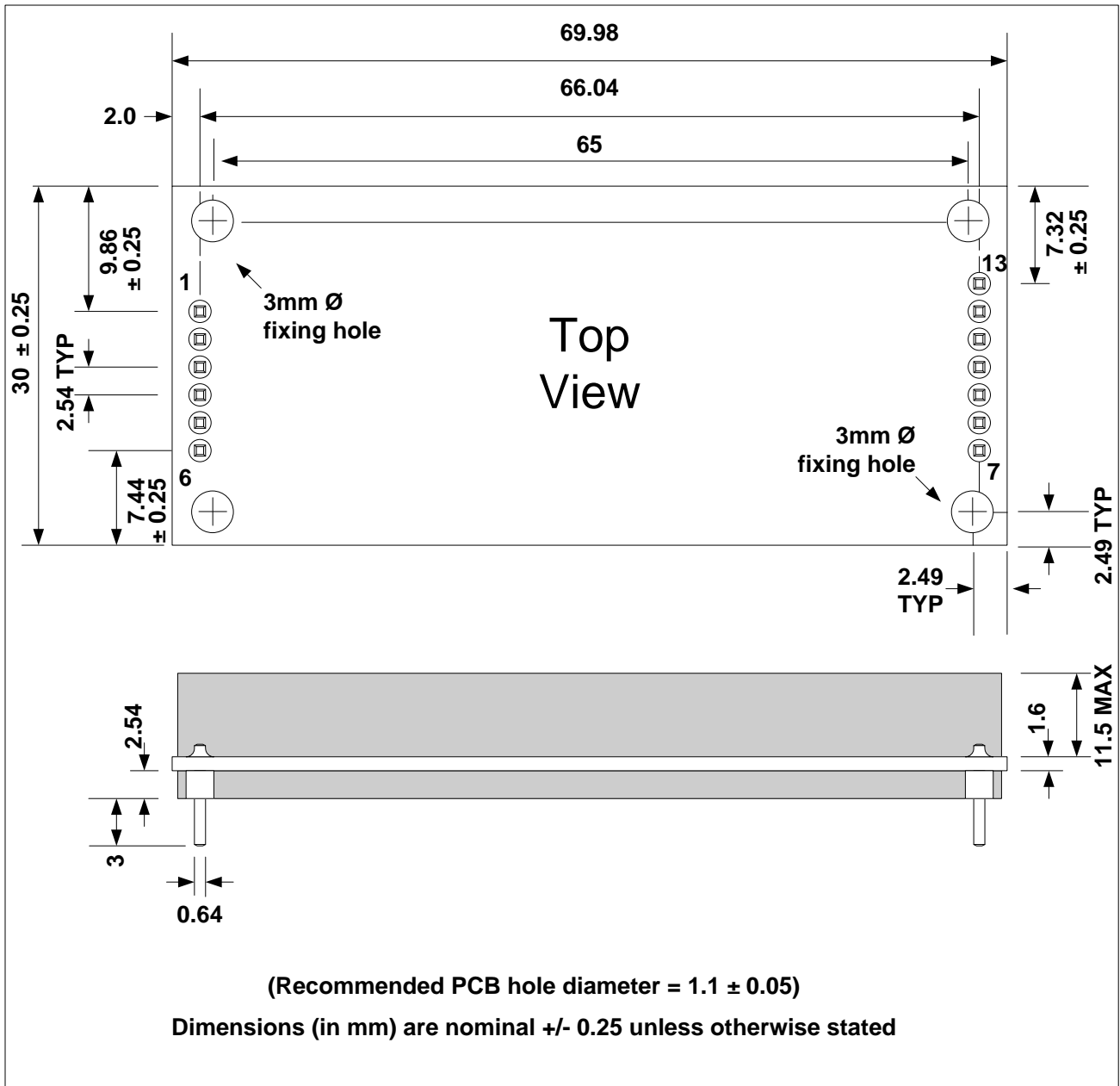

**Figure 16: Package Dimensions**

The latest revision of all application notes referenced in this document can be found on the Silver Telecom website "[www.silvertel.com](http://www.silvertel.com)".

Information published in this datasheet is believed to be correct and accurate. Silver Telecom assumes no liability for errors which may occur or for liability otherwise arising out of use of this information or infringement of patents which may occur as a result of such use. No license is granted by this document under patents owned by Silver Telecom or licensed from third parties by Silver Telecom. The products, their specification and information appearing in this document are subject to change by Silver Telecom without notice.