

DM2502, DM2503, DM2504

Successive Approximation Registers

The DM2502, DM2503, and DM2504 are 8-bit and 12-bit TTL registers designed for use in successive approximation A/D converters. These devices contain all the logic and control circuits necessary in combination with a D/A converter to perform successive approximation analog-to-digital conversions.

The DM2502 has 8 bits with serial capability and is not expandable. The DM2503 has 8 bits and is expandable without serial capability. The DM2504 has 12 bits with serial capability and expandability.

Rochester Electronics Manufactured Components

Rochester branded components are manufactured using either die/wafers purchased from the original suppliers or Rochester wafers recreated from the original IP. All recreations are done with the approval of the OCM.

Parts are tested using original factory test programs or Rochester developed test solutions to guarantee product meets or exceeds the OCM data sheet.

Quality Overview

- ISO-9001
- AS9120 certification
- Qualified Manufacturers List (QML) MIL-PRF-38535
 - Class Q Military
 - Class V Space Level
- Qualified Suppliers List of Distributors (QSLD)
 - Rochester is a critical supplier to DLA and meets all industry and DLA standards.

Rochester Electronics, LLC is committed to supplying products that satisfy customer expectations for quality and are equal to those originally supplied by industry manufacturers.

The original manufacturer's datasheet accompanying this document reflects the performance and specifications of the Rochester manufactured version of this device. Rochester Electronics guarantees the performance of its semiconductor products to the original OEM specifications. 'Typical' values are for reference purposes only. Certain minimum or maximum ratings may be based on product characterization, design, simulation, or sample testing.

DM2502, DM2503, DM2504 Successive Approximation Registers

General Description

The DM2502, DM2503 and DM2504 are 8-bit and 12-bit TTL registers designed for use in successive approximation A/D converters. These devices contain all the logic and control circuits necessary in combination with a D/A converter to perform successive approximation analog-to-digital conversions.

The DM2502 has 8 bits with serial capability and is not expandable. The DM2503 has 8 bits and is expandable without serial capability. The DM2504 has 12 bits with serial capability and expandability.

All three devices are available in ceramic DIP, ceramic flatpak, and molded Epoxy-B DIPs. The DM2502, DM2503 and

DM2504 operate over -55°C to $+125^{\circ}\text{C}$; the DM2502C, DM2503C and DM2504C operate over 0°C to $+70^{\circ}\text{C}$.

Features

- Complete logic for successive approximation A/D converters
- 8-bit and 12-bit registers
- Capable of short cycle or expanded operation
- Continuous or start-stop operation
- Compatible with D/A converters using any logic code
- Active low or active high logic outputs
- Use as general purpose serial-to-parallel converter or ring counter

Logic Diagram

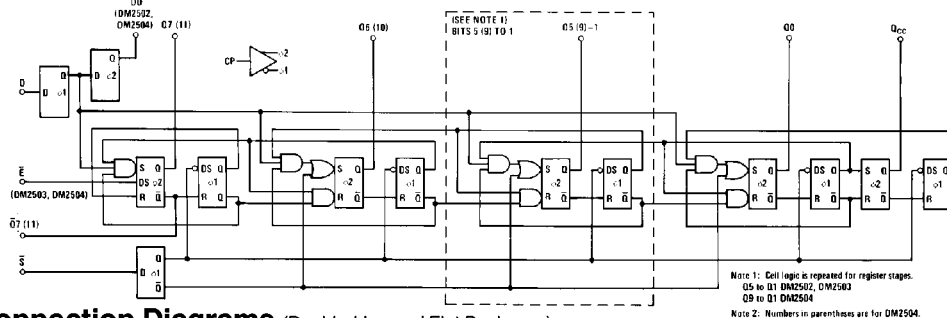

Connection Diagrams (Dual-In-Line and Flat Packages)

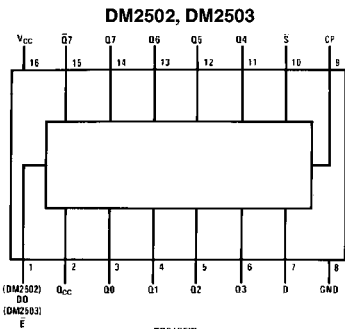

Order Number DM2502J, DM2502CJ, DM2503J or DM2503CJ
See NS Package J16A
Order Number DM2502CN or DM2503CN
See NS Package N16A
Order Number DM2502W, DM2502CW, DM2503W, or DM2503CW
See NS Package W16A

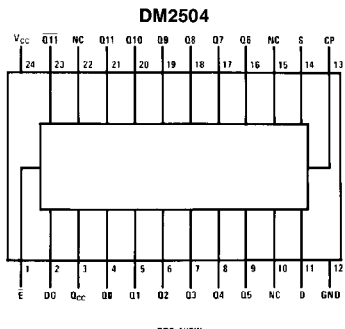

Order Number DM2504F or DM2504CJ
See NS Package F24D
Order Number DM2504J or DM2504CJ
See NS Package J24A
Order Number DM2504CN
See NS Package N24A

TL/F/5702-1

DM2502, DM2503, DM2504 Successive Approximation Registers

Absolute Maximum Ratings (Note 1)

Supply Voltage	7V
Input Voltage	5.5V
Output Voltage	5.5V
Storage Temperature Range	-65°C to +150°C
Lead Temperature (Soldering, 10 seconds)	300°C

Operating Conditions

	Min	Max	Units
Supply Voltage, V_{CC}			
DM2502C, DM2503C, DM2504C	4.75	5.25	V
DM2502, DM2503, DM2504	4.5	5.5	V
Temperature, T_A			
DM2502C, DM2503C, DM2504C	0	+70	°C
DM2502, DM2503, DM2504	-55	+125	°C

Electrical Characteristics (Notes 2 and 3) $V_{CC} = 5.0V$, $T_A = 25^\circ C$, $C_L = 15$ pF, unless otherwise specified.

Parameter	Conditions	Min	Typ	Max	Units
Logical "1" Input Voltage (V_{IH})	$V_{CC} = \text{Min}$	2.0			V
Logical "1" Input Current (I_{IH})	$V_{CC} = \text{Max}$				
CP Input	$V_{IH} = 2.4V$		6	40	μA
\bar{D} , \bar{E} , \bar{S} Inputs	$V_{IH} = 2.4V$		6	80	μA
All Inputs	$V_{IH} = 5.5V$			1.0	mA
Logical "0" Input Voltage (V_{IL})	$V_{CC} = \text{Min}$			0.8	V
Logical "0" Input Current (I_{IL})	$V_{CC} = \text{Max}$				
CP, \bar{S} Inputs	$V_{IL} = 0.4V$		-1.0	-1.6	mA
D, E Inputs	$V_{IL} = 0.4V$		-1.0	-3.2	mA
Logical "1" Output Voltage (V_{OH})	$V_{CC} = \text{Min}$, $I_{OH} = 0.48$ mA	2.4	3.6		V
Output Short Circuit Current (Note 4) (I_{OS})	$V_{CC} = \text{Max}$; $V_{OUT} = 0.0V$; Output High; CP, D, \bar{S} , High; \bar{E} Low	-10	-20	-45	mA
Logical "0" Output Voltage (V_{OL})	$V_{CC} = \text{Min}$, $I_{OL} = 9.6$ mA		0.2	0.4	V
Supply Current (I_{CC})	$V_{CC} = \text{Max}$, All Outputs Low				
DM2502C			65	95	mA
DM2502			65	85	mA
DM2503C			60	90	mA
DM2503			60	80	mA
DM2504C			90	124	mA
DM2504			90	110	mA
Propagation Delay to a Logical "0" From CP to Any Output (t_{pd0})		10	18	28	ns
Propagation Delay to a Logical "0" From \bar{E} to Q7 (Q11) Output (t_{pd0})	CP High, \bar{S} Low DM2503, DM2503C, DM2504, DM2504C Only		16	24	ns
Propagation Delay to a Logical "1" From CP to Any Output (t_{pd1})		10	26	38	ns
Propagation Delay to a Logical "1" From \bar{E} to Q7 (Q11) Output (t_{pd1})	CP High, \bar{S} Low DM2503, DM2503C, DM2504, DM2504C Only		13	19	ns
Set-Up Time Data Input ($t_{s(D)}$)		-10	4	8	ns
Set-Up Time Start Input ($t_{s(\bar{S})}$)		0	9	16	ns
Minimum Low CP Width (t_{pWL})			30	42	ns
Minimum High CP Width (t_{pWH})			17	24	ns
Maximum Clock Frequency (f_{MAX})		15	21		MHz

Note 1: "Absolute Maximum Ratings" are those values beyond which the safety of the device cannot be guaranteed. Except for "Operating Temperature Range" they are not meant to imply that the devices should be operated at these limits. The table of "Electrical Characteristics" provides conditions for actual device operation.

Note 2: Unless otherwise specified min/max limits apply across the -55°C to +125°C temperature range for the DM2502, DM2503 and DM2504, and across the 0°C to +70°C range for the DM2502C, DM2503C and DM2504C. All typicals are given for $V_{CC} = 5.0V$ and $T_A = 25^\circ C$.

Note 3: All currents into device pins shown as positive, out of device pins as negative, all voltages referenced to ground unless otherwise noted. All values shown as max or min on absolute value basis.

Note 4: Only one output at a time should be shorted.

Application Information

OPERATION

The registers consist of a set of master latches that act as the control elements in the device and change state on the input clock high-to-low transition and a set of slave latches that hold the register data and change on the input clock low-to-high transition. Externally the device acts as a special purpose serial-to-parallel converter that accepts data at the D input of the register and sends the data to the appropriate slave latch to appear at the register output and the DO output on the DM2502 and DM2504 when the clock goes from low-to-high. There are no restrictions on the data input; it can change state at any time except during a short interval centered about the clock low-to-high transition. At the same time that data enters the register bit the next less significant bit register is set to a low ready for the next iteration.

The register is reset by holding the \bar{S} (Start) signal low during the clock low-to-high transition. The register synchronously resets to the state Q7 (11) low, and all the remaining register outputs high. The Q_{CC} (Conversion Complete) signal is also set high at this time. The \bar{S} signal should not be brought back high until after the clock low-to-high transition in order to guarantee correct resetting. After the clock has gone high resetting the register, the \bar{S} signal must be removed. On the next clock low-to-high transition the data on the D input is set into the Q7 (11) register bit and the Q6 (10) register bit is set to a low ready for the next clock cycle. On the next clock low-to-high transition data enters the Q6 (10) register bit and Q5 (9) is set to a low. This operation is repeated for each register bit in turn until the register has been filled. When the data goes into Q0, the Q_{CC} signal goes low, and the register is inhibited from further change until reset by a Start signal.

The DM2502, DM2503 and DM2504 have a specially tailored two-phase clock generator to provide nonoverlapping two-phase clock pulses (i.e., the clock waveforms intersect below the thresholds of the gates they drive). Thus, even at

very slow dV/dt rates at the clock input (such as from relatively weak comparator outputs), improper logic operation will not result.

LOGIC CODES

All three registers can be operated with various logic codes. Two's complement code is used by offsetting the comparator $1/2$ full range + $1/2$ LSB and using the complement of the MSB ($\bar{Q}7$ or $\bar{Q}11$) with a binary D/A converter. Offset binary is used in the same manner but with the MSB ($\bar{Q}7$ or $\bar{Q}11$). BCD D/A converters can be used with the addition of illegal code suppression logic.

ACTIVE HIGH OR ACTIVE LOW LOGIC

The register can be used with either D/A converters that require a low voltage level to turn on, or D/A converters that require a high voltage level to turn the switch on. If D/A converters are used which turn on with a low logic level, the resulting digital output from the register is active low. That is, a logic "1" is represented as a low voltage level. If D/A converters are used that turn on with a high logic level then the digital output is active high; a logic "1" is represented as a high voltage level.

EXPANDED OPERATION

An active low enable input, \bar{E} , on the DM2503 and DM2504 allows registers to be connected together to form a longer register by connecting the clock, D, and \bar{S} inputs in parallel and connecting the Q_{CC} output of one register to the \bar{E} input of the next less significant register. When the start resets the register, the \bar{E} signal goes high, forcing the Q7 (11) bit high and inhibiting the register from accepting data until the previous register is full and its Q_{CC} goes low. If only one register is used the \bar{E} input should be held at a low logic level.

Timing Diagram

DM2502, DM2503

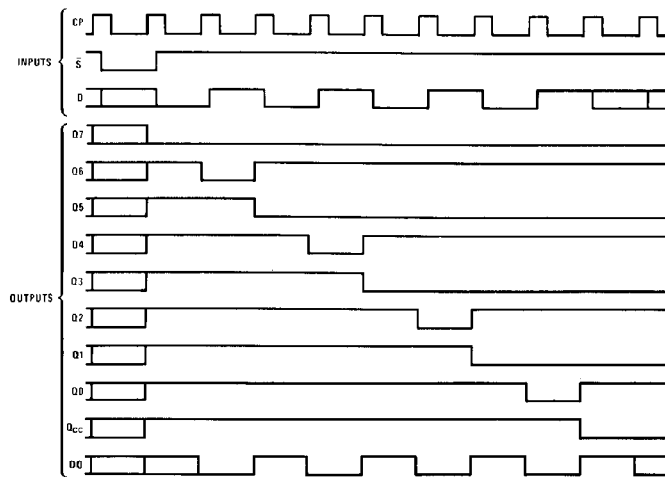

TL/F/5702-2

Application Information (Continued)

SHORT CYCLE

If all bits are not required, the register may be truncated and conversion time saved by using a register output going low rather than the Q_{CC} signal to indicate the end of conversion. If the register is truncated and operated in the continuous conversion mode, a lock-up condition may occur on power turn-on. This condition can be avoided by making the start input the OR function of Q_{CC} and the appropriate register output.

COMPARATOR BIAS

To minimize the digital error below $\pm 1/2$ LSB, the comparator must be biased. If a D/A converter is used which requires a low voltage level to turn on, the comparator should be biased $+1/2$ LSB. If the D/A converter requires a high logic level to turn on, the comparator must be biased $-1/2$ LSB.

Truth Table

DM2502, DM2503

Time	Inputs			Outputs ¹									
	D	\bar{S}	\bar{E}^2	D0 ³	Q7	Q6	Q5	Q4	Q3	Q2	Q1	Q0	Q _{CC}
0	X	L	L	X	X	X	X	X	X	X	X	X	X
1	D7	H	L	X	L	H	H	H	H	H	H	H	H
2	D6	H	L	D7	D7	L	H	H	H	H	H	H	H
3	D5	H	L	D6	D7	D6	L	H	H	H	H	H	H
4	D4	H	L	D5	D7	D6	D5	L	H	H	H	H	H
5	D3	H	L	D4	D7	D6	D5	D4	L	H	H	H	H
6	D2	H	L	D3	D7	D6	D5	D4	D3	L	H	H	H
7	D1	H	L	D2	D7	D6	D5	D4	D3	D2	L	H	H
8	D0	H	L	D1	D7	D6	D5	D4	D3	D2	D1	L	H
9	X	H	L	D0	D7	D6	D5	D4	D3	D2	D1	D0	L
10	X	X	L	X	D7	D6	D5	D4	D3	D2	D1	D0	L
	X	X	H	X	H	NC	NC	NC	NC	NC	NC	NC	NC

Note 1: Truth table for DM2504 is extended to include 12 outputs.

Note 2: Truth table for DM2502 does not include \bar{E} column or last line in truth table shown.

Note 3: Truth table for DM2503 does not include D0 column.

H = High Voltage Level

L = Low Voltage Level

X = Don't Care

NC = No Change

Typical Applications

BCD Illegal Code Suppression

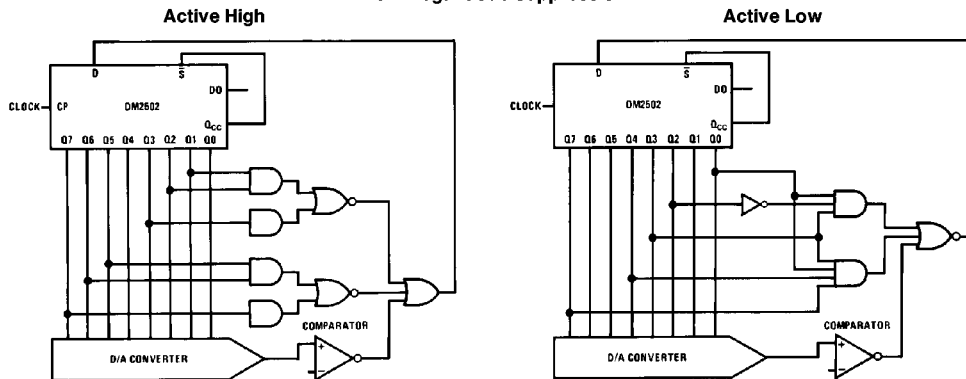

TL/F/5702-3

Typical Applications (Continued)

Fast Precision Analog-to-Digital Converter

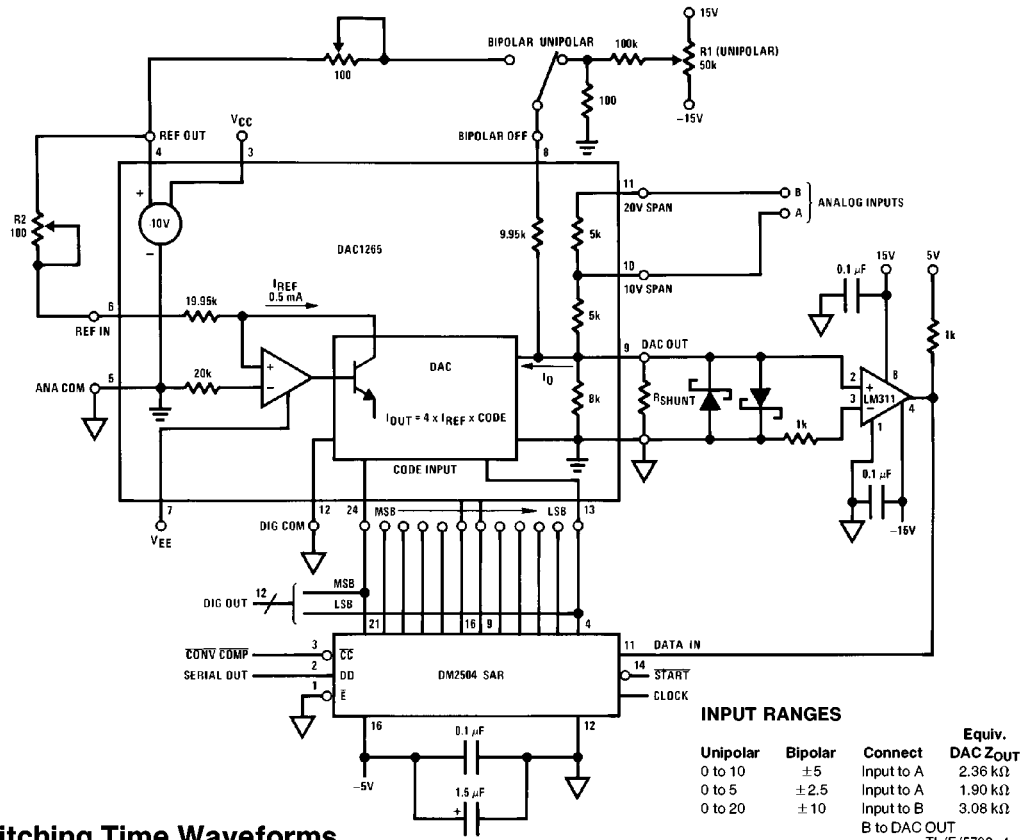

Switching Time Waveforms

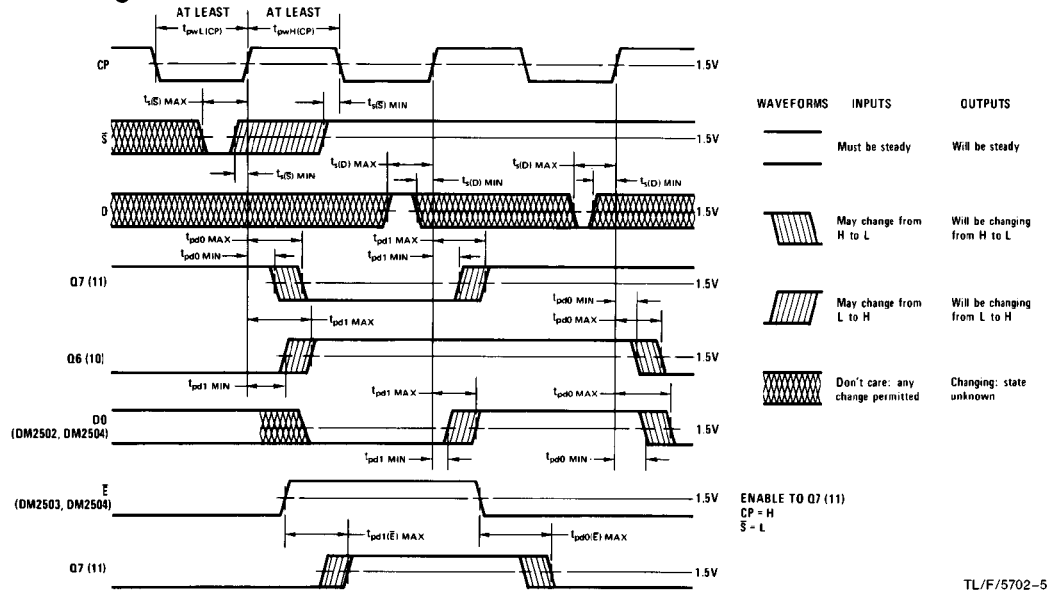

Physical Dimensions inches (millimeters)

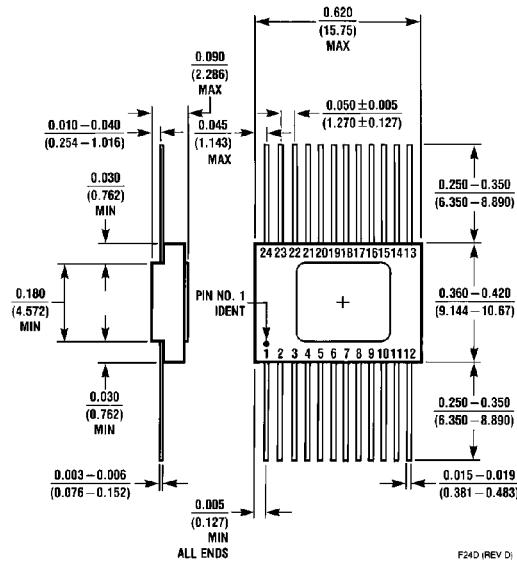

**Order Number DM2504F or DM2504CF
NS Package Number F24D**

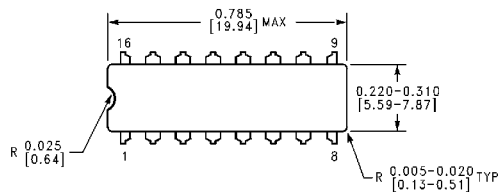

**Order Number DM2502J, DM2502CJ, DM2503J or DM2503CJ
NS Package Number J16A**

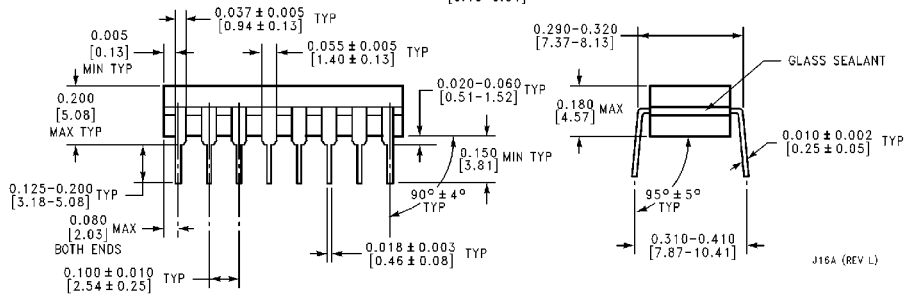

Physical Dimensions inches (millimeters) (Continued)

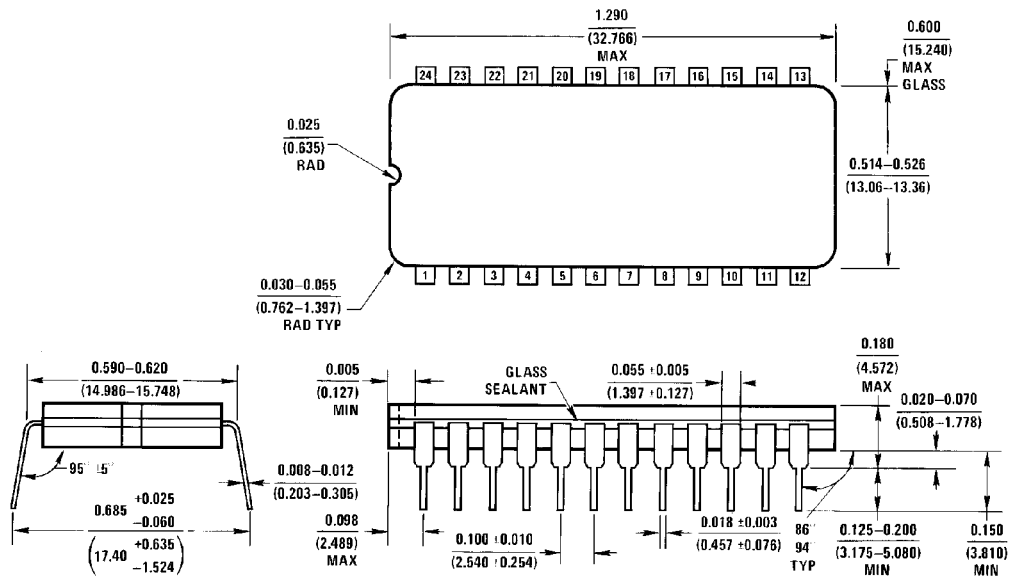

J24A (REV H)

Order Number DM2504J or DM2504CJ
NS Package Number J24A

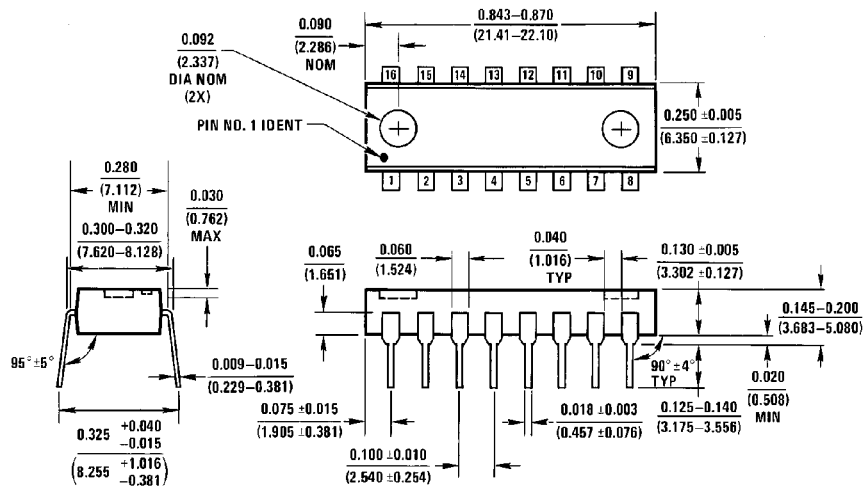

N16A (REV E)

Order Number DM2502CM or DM2503CN
NS Package Number N16A

Physical Dimensions inches (millimeters) (Continued)

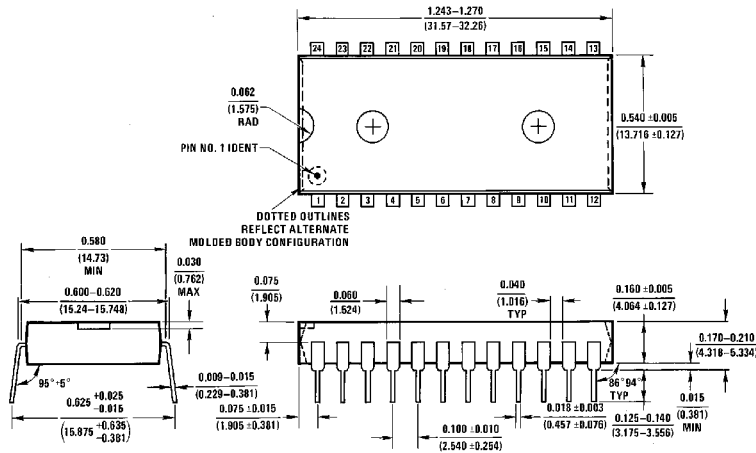

**Order Number DM2504CN
NS Package Number N24A**

N24A-REV D

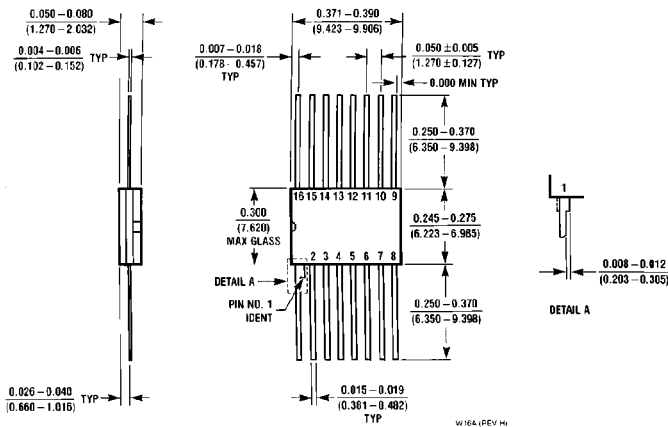

**Order Number DM2502W, DM2502CW, DM2503W, or DM2503CW
NS Package Number W16A**

W16A-REV H

LIFE SUPPORT POLICY

NATIONAL'S PRODUCTS ARE NOT AUTHORIZED FOR USE AS CRITICAL COMPONENTS IN LIFE SUPPORT DEVICES OR SYSTEMS WITHOUT THE EXPRESS WRITTEN APPROVAL OF THE PRESIDENT OF NATIONAL SEMICONDUCTOR CORPORATION. As used herein:

1. Life support devices or systems are devices or systems which, (a) are intended for surgical implant into the body, or (b) support or sustain life, and whose failure to perform, when properly used in accordance with instructions for use provided in the labeling, can be reasonably expected to result in a significant injury to the user.
2. A critical component is any component of a life support device or system whose failure to perform can be reasonably expected to cause the failure of the life support device or system, or to affect its safety or effectiveness.



National Semiconductor Corporation
1111 West Bardin Road
Arlington, TX 76017
Tel: 1(800) 272-9959
Fax: 1(800) 737-7018

National Semiconductor Europe
Fax: (+49) 0-180-530 85 86
Email: cnjwge@tevm2.nsc.com
Deutsch Tel: (+49) 0-180-530 85 85
English Tel: (+49) 0-180-532 78 32
Français Tel: (+49) 0-180-532 93 58
Italiano Tel: (+49) 0-180-534 16 80

National Semiconductor Hong Kong Ltd.
13th Floor, Straight Block,
Ocean Centre, 5 Canton Rd.
Tsimshatsui, Kowloon
Hong Kong
Tel: (852) 2737-1600
Fax: (852) 2736-9960

National Semiconductor Japan Ltd.
Tel: 81-043-299-2309
Fax: 81-043-299-2408

National does not assume any responsibility for use of any circuitry described, no circuit patent licenses are implied and National reserves the right at any time without notice to change said circuitry and specifications.