

COAXIAL SURGE PROTECTOR DEVICE, Fine protectors hybrid technology

3403.17.0063

Properties

- Two stages hybrid protection: GDT and fine protector
- Residual surge pulse energy reduced by about factor 100 compared to standard GDT
- Full lightning protection as standard gas discharge tube (GDT) protectors
- Gas discharge tube included
- DC/AC remote powering via coaxial same cable

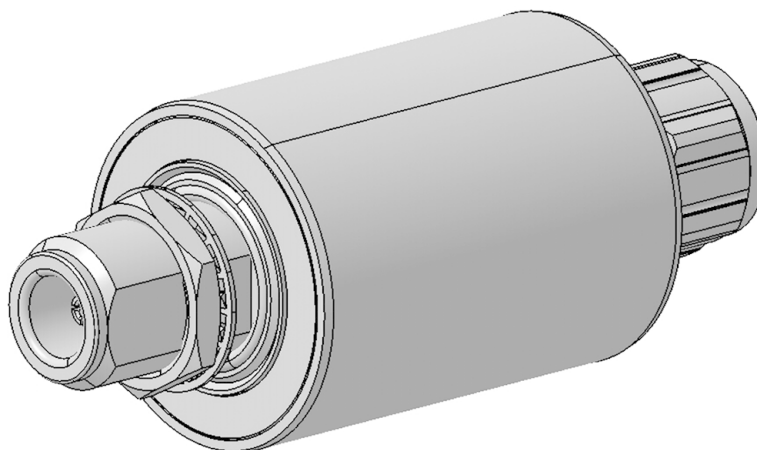

Product configuration

Main path connectors	Port 1: unprotected, N jack (female) Port 2: protected, N plug (male)
Mounting and grounding	MH12 (bulkhead mounting)
Side of bulkhead	unprotected side

Interface and material data

Housing material / plating	Aluminium / Chromatized
Center contact, material / plating	Port 1: Copper Beryllium Alloy / Gold Plating (without Nickel underplating) Port 2: Brass / Gold Plating (without Nickel underplating)

Electrical data

Impedance	50 Ω
Frequency frame	800 MHz to 2500 MHz
Return loss typical	26.44 dB
Insertion loss typical	0.3 dB
CW power frame	50 W
Residual pulse energy (typ.)	6 μ J (test pulse 4 kV 1.2/50 μ s; 2 kA 8/20 μ s)
Residual pulse voltage (typ.)	8 V LEMP (test pulse 4 kV 1.2/50 μ s; 2 kA 8/20 μ s)
Surge current handling capability	20 kA single (test pulse 8/20 μ s)

COAXIAL SURGE PROTECTOR DEVICE, Fine protectors hybrid technology

3403.17.0063

Electrical remarks	
DC supply voltage	6 V
DC current	4 A
Gas tube	Yes DC, GDT included, not replaceable

Mechanical data	
Weight	104 g
Mating cycles	100

Environmental data	
Operation temperature	-40 °C ... 85 °C
Storage temperature	-40 °C ... 85 °C
Ingress protection (IP Rating)	IP67
Thermal shock according	MIL-STD-202, Method 107, Cond. B
Vibration according	MIL-STD-202, Method 204, Cond. A
Moisture resistance according	MIL-STD-202, Method 106

Ordering Information Table	
Item number	Item description
84038163	3403.17.0063

HUBER+SUHNER is certified by ISO 9001, ISO 14001, ISO 45001, IATF 16949, AS/EN 9100 and ISO/TS 22163-IRIS. Waiver: Facts and figures herein are for information only and do not represent any warranty of any kind.
DOCUMENT PIM-PI987 / Date of publication: 17.04.2024 / uncontrolled copy