	E480232
---	----------------

Features

- Low Inductance
- Built in Strain Relief
- For Surface Mount Application in Order to Optimize Board Space
- High Temperature Soldering: 260°C/10 Seconds at Terminals
- Low Profile Package
- Repetition Rate(duty cycle): 0.01%
- Glass Passivated Junction
- Excellent Clamping Capability
- Halogen Free. "Green" Device (Note 1)
- Moisture Sensitivity Level 1
- Epoxy Meets UL 94 V-0 Flammability Rating
- Fast response time: Typically less than 1.0ps from 0 Volts to BV Min
- Lead Free Finish/RoHS Compliant (Note2) ("P" Suffix Designates Compliant. See Ordering Information)
- ESD protection of data lines in accordance with IEC 61000-4-2, 30kV(Air),30kV (Contact)



Maximum Ratings

Parameter	Symbol	Value	Unit
Peak Pulse Power Surge Current with a 10/1000µs Waveform (Note 3)	I_{PPM}	See Next Table	A
Peak Pulse Power Dissipation(Note 3)	P_{PPM}	5000	W
Power Dissipation on infinite heat sink at TL= 75°	P_D	6.5	W
Maximum instantaneous forward voltage at 100 A for unidirectional only	V_F	5	V

Note:

1. Halogen free "Green" products are defined as those which contain <900ppm bromine, <900ppm chlorine (<1500ppm total Br + Cl) and <1000ppm antimony compounds.
2. High Temperature Solder Exemption Applied, see EU Directive Annex 7a.
3. Non-repetitive current pulse, per Fig.3 and derated above $T_A=25^\circ\text{C}$ per Fig.4.
4. 8.3ms, single half sine wave duty cycle = 4 pulses per Minutes maximum.

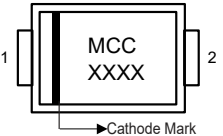
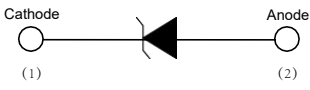
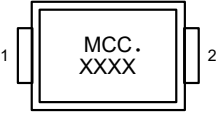
Internal Structure

Description	Simplified outline	Graphic symbol
Uni-directional		
Bi-directional		

XXXX = Marking code

5000Watt TVS 11 to 400 Volts

SMC (DO-214AB) (LEAD FRAME)

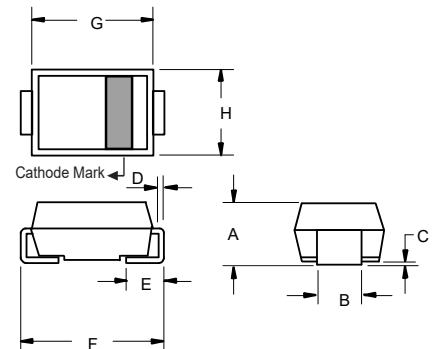

DIM	INCHES		MM		NOTE
	MIN	MAX	MIN	MAX	
A	0.079	0.103	2.00	2.62	
B	0.108	0.128	2.75	3.25	
C	0.002	0.008	0.051	0.203	
D	0.006	0.012	0.152	0.305	
E	0.030	0.060	0.76	1.52	
F	0.305	0.320	7.75	8.13	
G	0.260	0.280	6.60	7.11	
H	0.220	0.245	5.59	6.22	

Suggested Solder Pad Layout

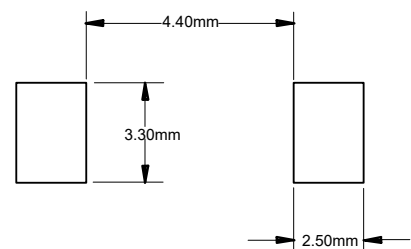

Thermal Characteristics

Parameter	Symbol	Value	Unit
Operating Junction Temperature Range	T_J	-55 to +175	°C
Storage Temperature Range	T_{STG}	-55 to +175	°C
Typical Thermal Resistance Junction to Lead	$R_{\theta JL}$	15	°C/W
Typical Thermal Resistance Junction to Ambient	$R_{\theta JA}$	75	°C/W
Typical Thermal Resistance Junction to Case	$R_{\theta JC}$	13	°C/W

Note:
5. Mounted on 0.31 x 0.31" (8.0 x 8.0 mm) copper pads to each terminal.

Electrical Characteristics @ 25°C Unless Otherwise Specified

MCC Part Number		Working Peak Reverse Voltage	Breakdown Voltage V_{BR} @ I_T			Maximum Clamping Voltage @ I_{PP}	Maximum Reverse Surge Current	Maximum Reverse Leakage @ V_{RWM}	Device Marking Code	
(Uni)	(Bi)		$V_{RWM}(V)$	Min (V)	Max (V)				I_T (mA)	$V_C(V)$
5.0SMLJ11A	5.0SMLJ11CA	11	12.2	13.5	10	18.2	275.0	800	5PEN	5BEN
5.0SMLJ12A	5.0SMLJ12CA	12	13.3	14.7	10	19.9	252.0	800	5PEP	5BEP
5.0SMLJ13A	5.0SMLJ13CA	13	14.4	15.9	10	21.5	233.0	500	5PEQ	5BEQ
5.0SMLJ14A	5.0SMLJ14CA	14	15.6	17.2	10	23.2	216.0	200	5PER	5BER
5.0SMLJ15A	5.0SMLJ15CA	15	16.7	18.5	1	24.4	205.0	100	5PES	5BES
5.0SMLJ16A	5.0SMLJ16CA	16	17.8	19.7	1	26.0	193.0	50	5PET	5BET
5.0SMLJ17A	5.0SMLJ17CA	17	18.9	20.9	1	27.6	181.0	20	5PEU	5BEU
5.0SMLJ18A	5.0SMLJ18CA	18	20.0	22.1	1	29.2	172.0	10	5PEV	5BEV
5.0SMLJ20A	5.0SMLJ20CA	20	22.2	24.5	1	32.4	155.0	5	5PEW	5BEW
5.0SMLJ22A	5.0SMLJ22CA	22	24.4	26.9	1	35.5	141.0	5	5PEX	5BEX
5.0SMLJ24A	5.0SMLJ24CA	24	26.7	29.5	1	38.9	129.0	5	5PEZ	5BEZ
5.0SMLJ26A	5.0SMLJ26CA	26	28.9	31.9	1	42.1	119.0	5	5PFE	5BFE
5.0SMLJ28A	5.0SMLJ28CA	28	31.1	34.4	1	45.4	110.0	5	5PFG	5BFG
5.0SMLJ30A	5.0SMLJ30CA	30	33.3	36.8	1	48.4	103.0	5	5PFK	5BFK
5.0SMLJ33A	5.0SMLJ33CA	33	36.7	40.6	1	53.3	93.9	5	5PFM	5BFM
5.0SMLJ36A	5.0SMLJ36CA	36	40.0	44.2	1	58.1	86.1	5	5PFP	5BFP
5.0SMLJ40A	5.0SMLJ40CA	40	44.4	49.1	1	64.5	77.6	5	5PFR	5BFR
5.0SMLJ43A	5.0SMLJ43CA	43	47.8	52.8	1	69.4	72.1	5	5PFT	5BFT
5.0SMLJ45A	5.0SMLJ45CA	45	50.0	55.3	1	72.7	68.8	5	5PFV	5BFV
5.0SMLJ48A	5.0SMLJ48CA	48	53.3	58.9	1	77.4	64.7	5	5PFX	5BFX
5.0SMLJ51A	5.0SMLJ51CA	51	56.7	62.7	1	82.4	60.7	5	5PFZ	5BFZ
5.0SMLJ54A	5.0SMLJ54CA	54	60.0	66.3	1	87.1	57.5	5	5RGE	5BGE
5.0SMLJ58A	5.0SMLJ58CA	58	64.4	71.2	1	93.6	53.5	5	5PGG	5BGG
5.0SMLJ60A	5.0SMLJ60CA	60	66.7	73.7	1	96.8	51.7	5	5PGK	5BGK
5.0SMLJ64A	5.0SMLJ64CA	64	71.1	78.6	1	103.0	48.6	5	5PGM	5BGM
5.0SMLJ70A	5.0SMLJ70CA	70	77.8	86.0	1	113.0	44.3	5	5PGP	5BGP
5.0SMLJ75A	5.0SMLJ75CA	75	83.3	92.1	1	121.0	41.4	5	5PGR	5BGR
5.0SMLJ78A	5.0SMLJ78CA	78	86.7	95.8	1	126.0	39.7	5	5PGT	5BGT
5.0SMLJ85A	5.0SMLJ85CA	85	94.4	104.0	1	137.0	36.5	5	5PGV	5BGV
5.0SMLJ90A	5.0SMLJ90CA	90	100.0	111.0	1	146.0	34.3	5	5PGX	5BGX
5.0SMLJ100A	5.0SMLJ100CA	100	111.0	123.0	1	162.0	30.9	5	5PGZ	5BGZ
5.0SMLJ110A	5.0SMLJ110CA	110	122.0	135.0	1	177.0	28.3	5	5PHE	5BHE
5.0SMLJ120A	5.0SMLJ120CA	120	133.0	147.0	1	193.0	26.0	5	5PHG	5BHG
5.0SMLJ130A	5.0SMLJ130CA	130	144.0	159.0	1	209.0	24.0	5	5PHK	5BHK
5.0SMLJ150A	5.0SMLJ150CA	150	167.0	185.0	1	243.0	20.6	5	5PHM	5BHM
5.0SMLJ160A	5.0SMLJ160CA	160	178.0	197.0	1	259.0	19.3	5	5PHP	5BHP
5.0SMLJ170A	5.0SMLJ170CA	170	189.0	209.0	1	275.0	18.2	5	5PHR	5BHR
5.0SMLJ180A	5.0SMLJ180CA	180	200.0	220.0	1	292.0	17.1	5	5PHT	5BHT
5.0SMLJ190A	5.0SMLJ190CA	190	211.0	258.0	1	308.0	16.2	5	5PHV	5BHV
5.0SMLJ200A	5.0SMLJ200CA	200	224.0	247.0	1	324.0	15.4	5	5PHW	5BHW
5.0SMLJ220A	5.0SMLJ220CA	220	246.0	272.0	1	356.0	14.0	5	5PHX	5BHX
5.0SMLJ250A	5.0SMLJ250CA	250	279.0	309.0	1	405.0	12.3	5	5PHZ	5BHZ
5.0SMLJ300A	5.0SMLJ300CA	300	335.0	371.0	1	486.0	10.3	5	5PJE	5BJE
5.0SMLJ350A	5.0SMLJ350CA	350	391.0	432.0	1	567.0	8.8	5	5PJG	5BJG
5.0SMLJ400A	5.0SMLJ400CA	400	447.0	494.0	1	648.0	7.7	5	5PJK	5BJK

Note:

4. Add suffix 'C' after part number to specify Bi-directional devices
5. For Bi-Directional devices having V_R of 10 volts, the I_R limit is double

Curve Characteristics

Fig. 1 - Peak Pulse Power Rating Curve

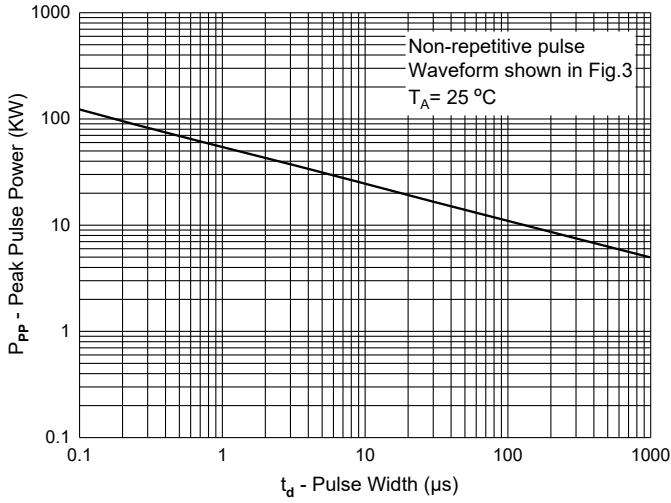

Fig. 2 - Typical Junction Capacitance

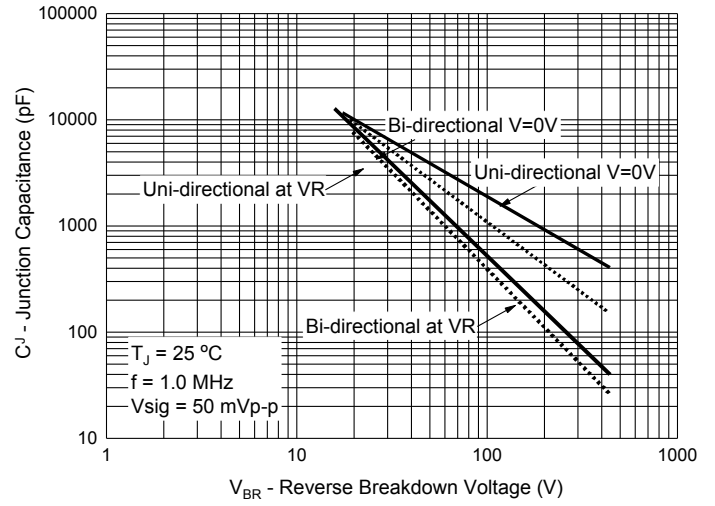

Fig. 3 - Pulse Waveform

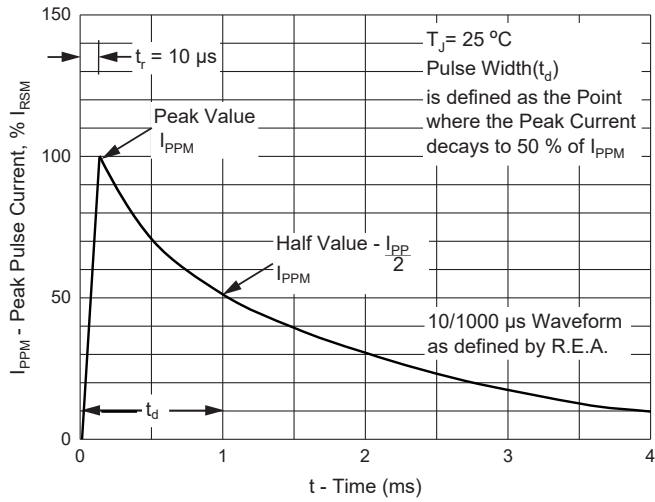
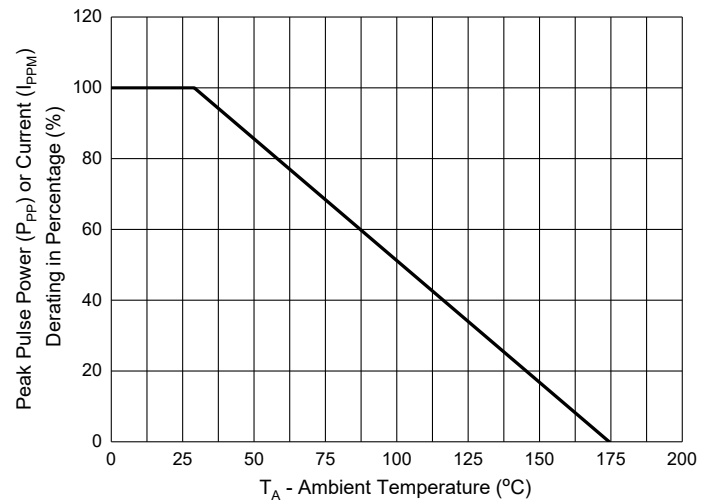

Fig. 4 - Pulse Derating Curve



Ordering Information

Device	Packing
Part Number-TP	Tape&Reel:3Kpcs/Reel

IMPORTANT NOTICE

Micro Commercial Components Corp. reserves the right to make changes without further notice to any product herein to make corrections, modifications, enhancements, improvements, or other changes. **Micro Commercial Components Corp.** does not assume any liability arising out of the application or use of any product described herein; neither does it convey any license under its patent rights, nor the rights of others. The user of products in such applications shall assume all risks of such use and will agree to hold **Micro Commercial Components Corp.** and all the companies whose products are represented on our website, harmless against all damages. **Micro Commercial Components Corp.** products are sold subject to the general terms and conditions of commercial sale, as published at <https://www.mccsemi.com/Home/TermsAndConditions>.

LIFE SUPPORT

MCC's products are not authorized for use as critical components in life support devices or systems without the express written approval of Micro Commercial Components Corporation.

CUSTOMER AWARENESS

Counterfeiting of semiconductor parts is a growing problem in the industry. Micro Commercial Components (MCC) is taking strong measures to protect ourselves and our customers from the proliferation of counterfeit parts. MCC strongly encourages customers to purchase MCC parts either directly from MCC or from Authorized MCC Distributors who are listed by country on our web page cited below. Products customers buy either from MCC directly or from Authorized MCC Distributors are genuine parts, have full traceability, meet MCC's quality standards for handling and storage. **MCC will not provide any warranty coverage or other assistance for parts bought from Unauthorized Sources.** MCC is committed to combat this global problem and encourage our customers to do their part in stopping this practice by buying direct or from authorized distributors.