

REV.	NOTES	DATE
A	RELEASED	2022/05/20

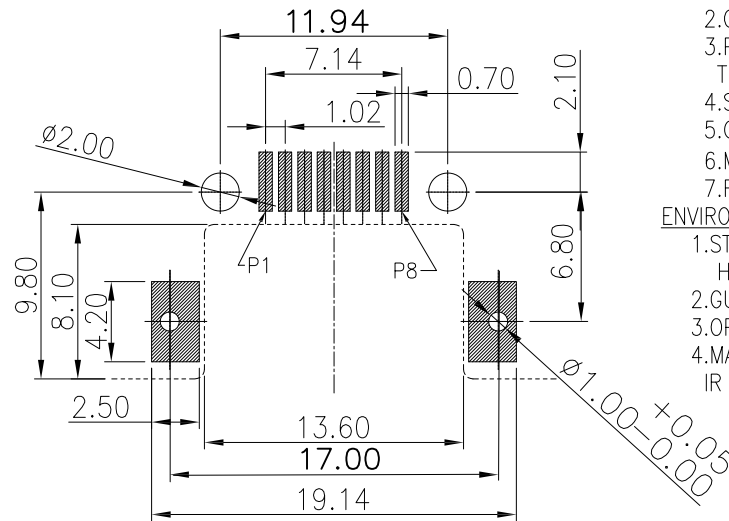
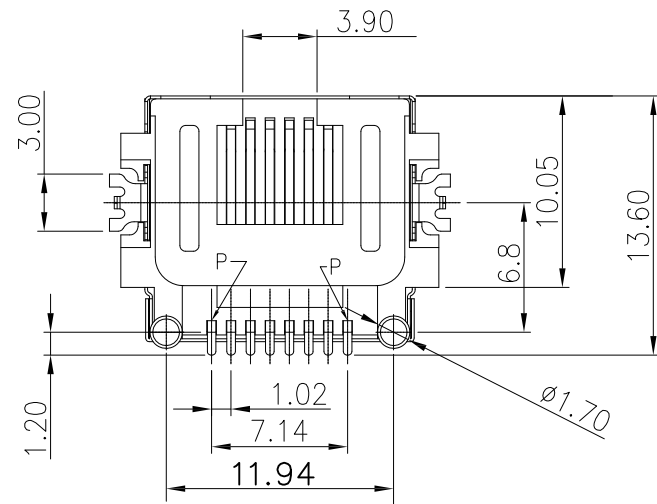
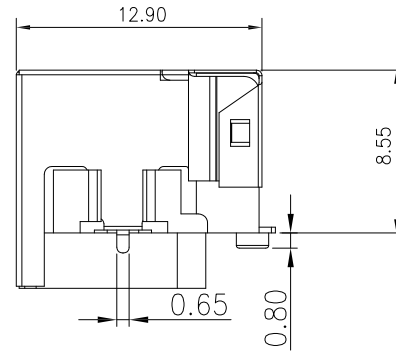
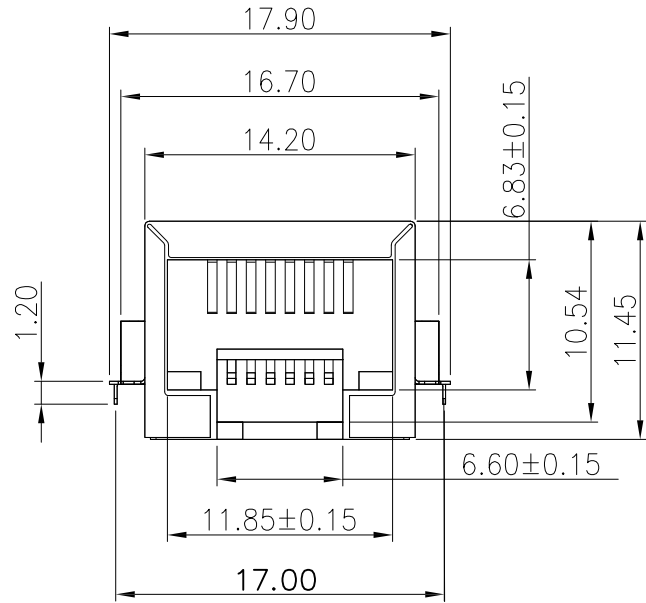

SPECIFICATION NOTES:

ELECTRICAL:

- 1.VOLTAGE RATING: 125 VAC RMS
- 2.CURRENT RATING: 1.5 AMP
- 3.CONTACT RESISTANCE: 20mΩ MAX.
- 4.INSULATION RESISTANCE: 1000MΩ MIN. AT500V DC.
- 5.DIELECTRIC STRENGTH: 1000 V AC OR 1500V DC RMS AT 0.5mA 50 Hz / 60 Hz FOR 1MINUTE

MECHANICAL:

- 1.HOUSING:LCP BLACK, UL 94V-0
- 2.CONTACT:PHOSPHOR BRONZE T=0.30MM
- 3.PLATING:GOLD PLATING AT CONTACT AREA, MATTE TIN AT TAIL 100U MIN., NICKEL 30U MIN. OVER ALL.
- 4.SHELL:BRASS T=0.15
- 5.OPERATING LIFE:750 CYCLES MIN.
- 6.MATING/UNMATING FORCE: 30N/3.06KGf MAX.
- 7.RETENTION STRENGTH:50N OR 30N MIN.FOR 60S±5S

ENVIRONMENTAL:

- 1.STORAGE:-40°C TO +85°C RELATIVE HUMIDITY<80%
- 2.GUARANTEE PERIOD:12 MONTHS
- 3.OPERATION: -40°C TO +85°C
- 4.MANUAL SOLDERING PARAMETERS:24H IR TEMPERATURE: 260±5°C 5~10 SECONDS.

RECOMMENDED PCB LAYOUT

PTOLERANCE=±0.05

DIMENSIONS TOLERANCE METRIC

- X :±0.5
- X.X :±0.38
- X.XX :±0.25
- ANGLES
- X :±1°
- X.X :±0.5°

單位(UNITS)	mm
數量(QT'Y)	N/A
材料(MT'L)	SEE NOTE
處理(FINISH)	SEE NOTE



圖名(NAME)		RJ45正口8P8C 沉板式8.60MM全包 黑色 HF			
繪圖(DRAW)		料號(PART NUMBER)		AAOE+8P8C+10610	
設計(DE'N)		圖號(DRAW NUMBER)			
審校(CH'K)		圖檔(FILE NAME .DWG)			
核准(APP'D)		比例(SCALE)	1/1	圖紙(SIZE)	A4
		頁次(SHEET)	1/2	版次(REV.)	A

REV.	NOTES	DATE
A	RELEASED	2022/05/20

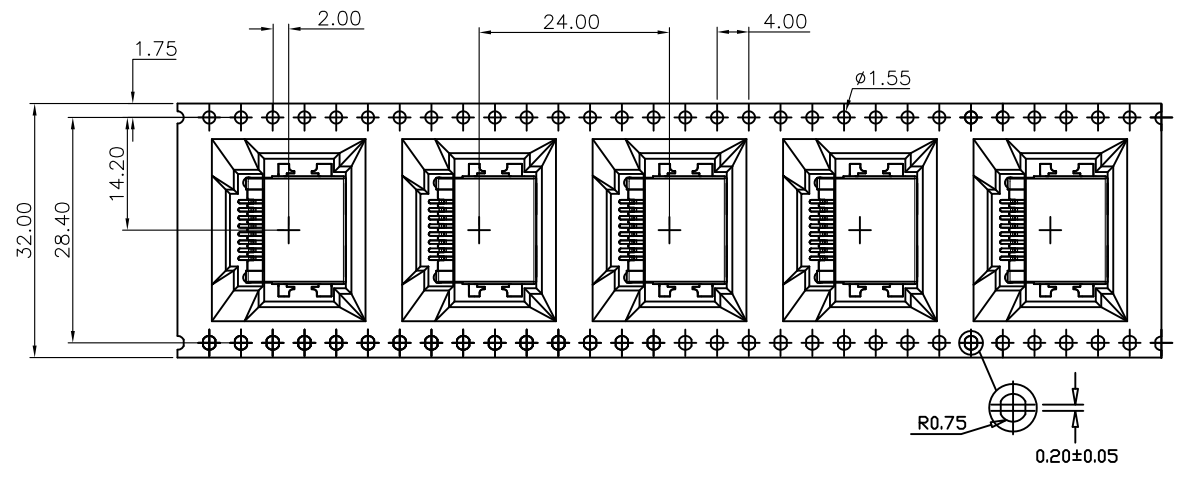
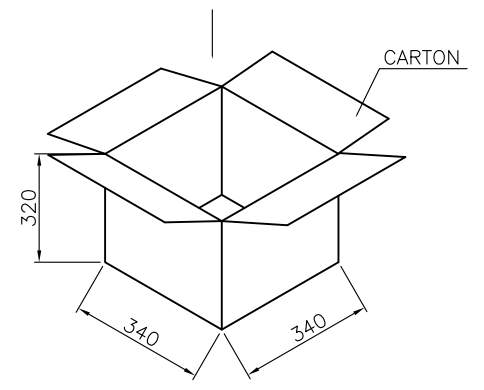
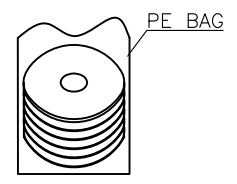
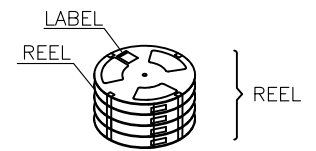
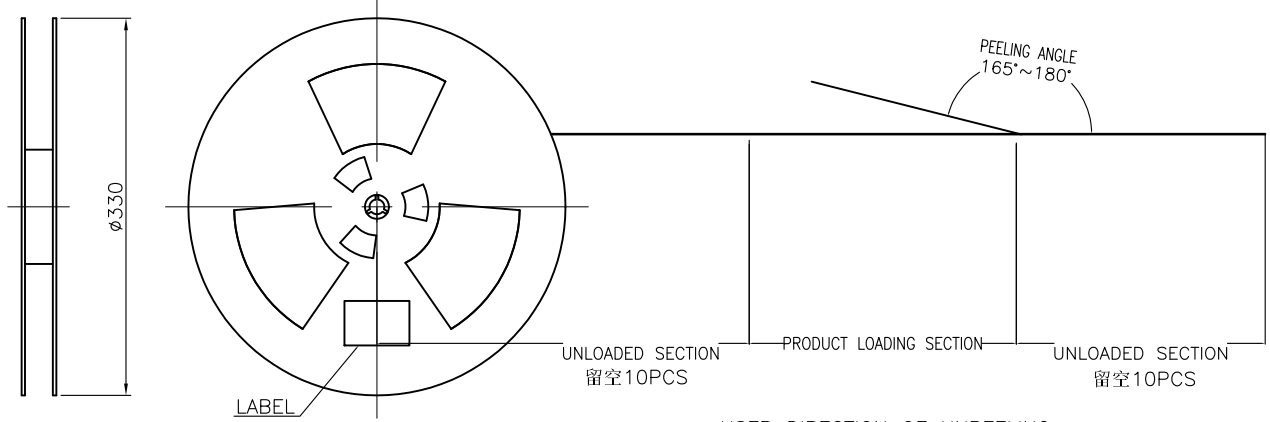

PACKING CAPACITY		
PCS/RELL	REEL/CARTON	PCS/CARTON
250	10	2500

DIMENSIONS TOLERANCE METRIC	
X	:±0.5
X.X	:±0.38
X.XX	:±0.25
ANGLES	
X	:±1°
X.X	:±0.5°

單位(UNITS)	mm
數量(QT'Y)	N/A
材料(MT'L)	SEE NOTE
處理(FINISH)	SEE NOTE

EASE electronics
Ease Electronics Co., Limited

繪圖(DRAW)		圖名(NAME)	RJ45正口8P8C 沉板式8.60MM全包 黑色 HIF				
設計(DE'N)		料號(PART NUMBER)	AAOE+8P8C+10610				
審校(CH'K)		圖號(DRAW NUMBER)					
核准(APP'D)		圖檔(FILE NAME .DWG)					
比例(SCALE)	1/1	圖紙(SIZE)	A4	頁次(SHEET)	2/2	版次(REV.)	A