

Ambient Light Sensor

Surface - Mount

ALS-PT17-51NB/L369/TR8

Features

- Close responsively to the human eye spectrum
- Light to Current, analog output
- Good output linearity across wide illumination range
- Low sensitivity variation across various light sources
- Operating temperature performance, -40oC to 85oC
- Wide supply voltage range, 1.8V to 5.5V
- Size : 2.0mm(L)*1.25mm(W)*0.8mm(H)
- The product itself will remain within RoHS compliant version
- Compliance with EU REACH
- Compliance Halogen Free(Br < 900ppm, Cl < 900ppm, Br+Cl < 1500ppm)

Description

The ALS-PT17-51NB/L369/TR8 is an ambient light sensor, consisting of phototransistor in miniature SMD. EVERLIGHT ALS series product are a good effective solution to the power saving of display backlighting of mobile appliances, such as the mobile phones, NB and PDAs. Due to the high rejection ratio of infrared radiation, the spectral response of the ambient light sensor is close to that of human eyes.

Applications

- Detection of ambient light to control display backlighting
- Mobile devices – Mobile phones, PDAs
 - Computing device – TFT LCD monitor for notebook computer
 - Consumer device – TFT LCD TV, Plasma TV, Video camera, Digital camera, Toys
- Automatic residential and commercial management
- Automatic contrast enhancement for electronic signboard
- Ambient light monitoring device for daylight and artificial light
 - Street light, CCD/CCTV

Package Dimensions

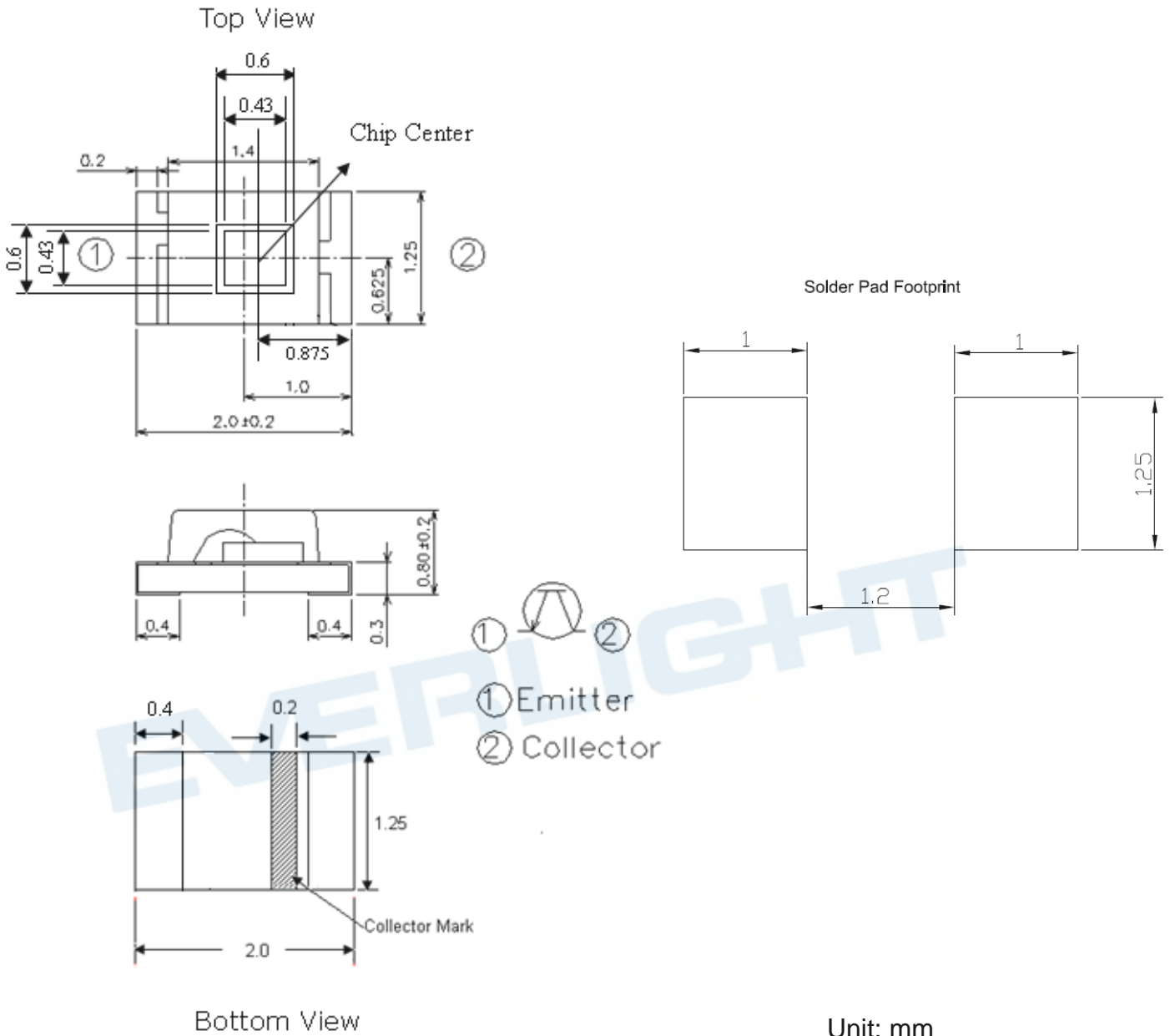

Unit: mm
 Tolerance: ±0.1mm

Absolute Maximum Ratings

Parameter	Symbol	Rating	Unit
Supply Voltage	V _{cc}	-0.5~6.0	V
Operating Temperature Range	T _{opr}	-40 ~ +85	°C
Storage Temperature Range	T _{stg}	-40 ~ +100	°C
Soldering Temperature Range [Note1]	T _{sol}	260 ± 10	°C

Note1: For detail reflow time and the recommended temperature profile, please refer to page 7.

Recommended Operating Conditions

Parameter	Symbol	Min.	Max.	Unit
Operating Temperature	T _{opr}	-40	+85	°C
Supply Voltage	V _{cc}	2.5	5.5	V

EVERLIGHT

Electrical and Optical Characteristics (T_a=25°C)

Parameter	Symbol	MIN	TYP.	MAX.	Unit	Test Condition
Dark Current	I _D	---	2	100	nA	V _{CE} =5V, E _v = 0Lux
Light Current	I _{L1}	0.35	0.55	0.7	uA	V _{CE} =5V, E _v = 5Lx [Note1]
	I _{L2}	3.5	5.5	7	uA	V _{CE} =5V, E _v = 50Lx [Note1]
	I _{L3}	35	55	70	uA	V _{CE} =5V, E _v = 500Lx [Note1]
Saturation Output Voltage	V _O	---	4.5	---	V	V _{CE} =5V, E _v = 1000Lx R _L =75KΩ [Note2]
Peak Sensitivity Wavelength	λ _p	---	580	---	nm	
Sensitivity Wavelength Range	λ	400	---	700	nm	
Rise time	t _r	---	0.13	---	ms	V _{CE} = 5 V R _L = 7.5KΩ
Fall time	t _f	---	0.15	---	ms	
Angle of half Sensitivity	2θ _{1/2}	---	130	---	Deg.	

Note:

1. White Fluorescent light (Color Temperature = 6500K) is used as light source. However, White LED is substituted in mass production.
2. Illuminance by CIE standard illuminant-A / 2856K, incandescent lamp.

Typical Electrical and Optical Characteristics Curves

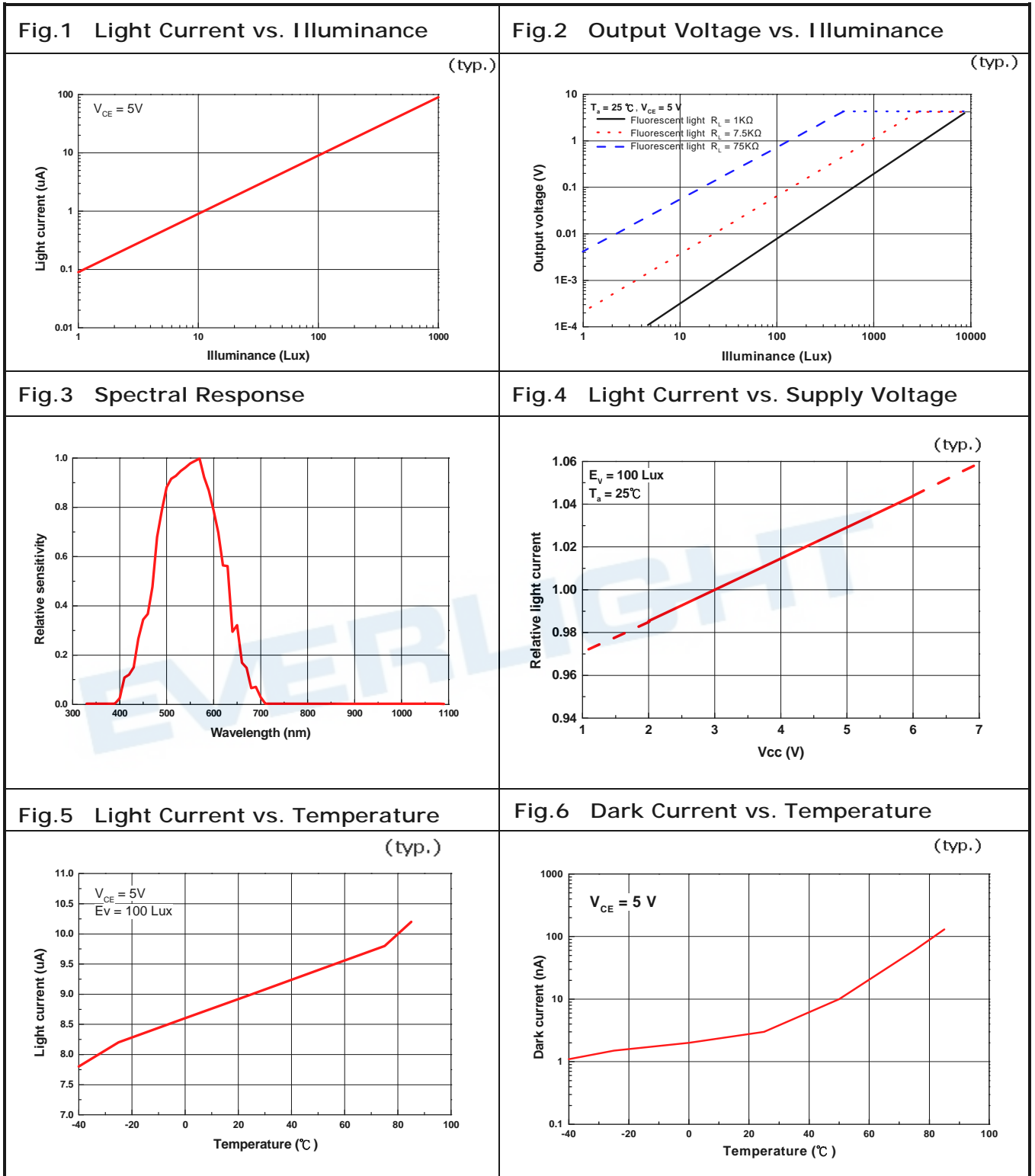

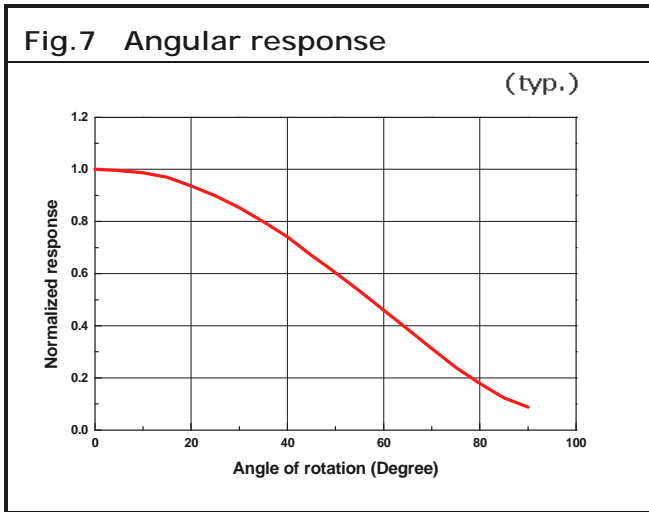

Converting Photocurrent to Voltage

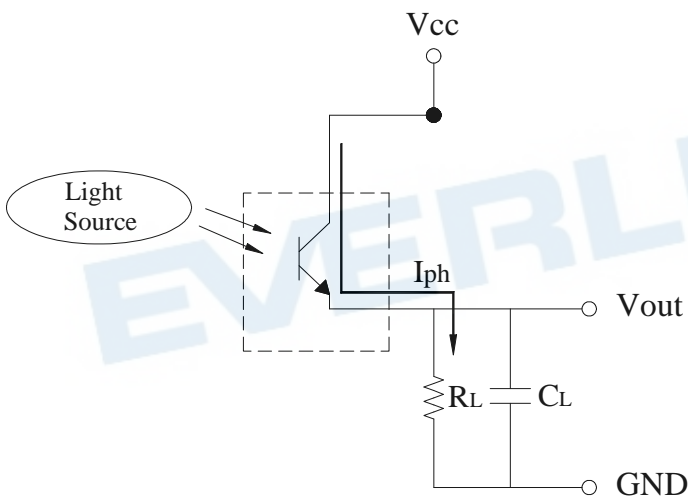

Note:

1. The output voltage (V_{out}) is the product of photocurrent (I_{PH}) and loading resistor (R_L)
2. A right loading resistor shall be chosen to meet the requirement of maximum ambient light, and output saturation voltage:

$$V_{out(max.)} = I_{out(max.)} \times R_L \leq V_{out(saturation)} = V_{CC} - 0.4V$$

3. To avoid 60Hz ripple from fluorescent lamps, we suggest that the time constant must be greater than 0.5 second:

$$R_L \times C_L \geq 0.5 \quad (\text{empirical data})$$

Recommended method of storage

Reflow Terms: JEDEC Level 3 Specification

Dry box storage is recommended as soon as the aluminum bag has been opened prevent

1. Over-current-proof

Customer must apply resistors for protection, otherwise slight voltage shift might cause big current happen. (Burned-out might happen).

2. Storage

- (1) Do not open moisture proof bag before components are ready to use.
- (2) Before opening moisture proof bag, components should be kept at 30°C or less and 90%RH or less.
- (3) Components should be used within a year.
- (4) After opened moisture proof bag, components should be kept at 30°C or less and 70%RH or less.
- (5) Components should be used within 168 hours after opened moisture proof bag.
- (6) If the moisture absorbent material (silica gel) has faded away or the components have exceeded the storage time, baking treatment should be performed using the following conditions. (Baking treatment: 60±5°C for 24 hours)

ESD Precaution:

Proper storage and handing procedures should be followed to prevent ESD damage to the devices especially when they are removed from the Anti-static bag. Electro-Static Sensitive Devices warning labels are on the packing.

Recommended Solder Profile

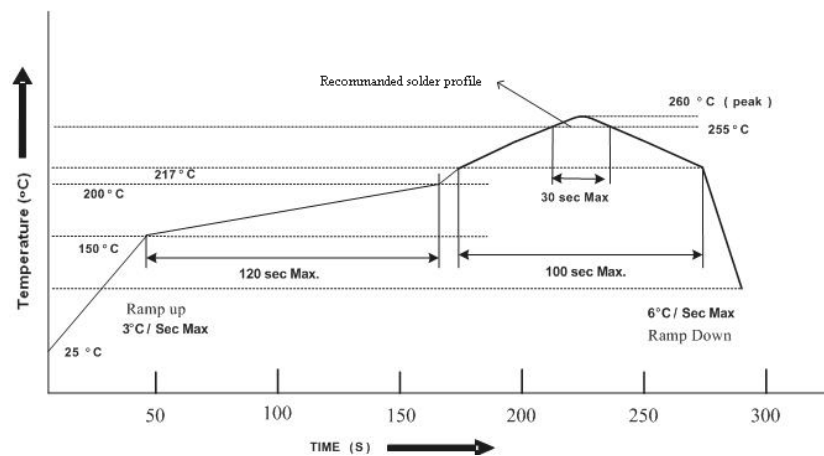

Notice:

- (1) Reflow soldering should not be done more than two times.
- (2) When soldering, do not put stress on the devices during heating.
- (3) After soldering, do not warp the circuit board.

Soldering Iron

Each terminal is to go to the tip of soldering iron temperature less than 350°C for 3 seconds within once in less than the soldering iron capacity 25W. Leave two seconds and more intervals, and do soldering of each terminal. Be careful because the damage of the product is often started at the time of the hand solder.

Repairing

Repair should not be done after the device have been soldered. When repairing is unavoidable, a double-head soldering iron should be used (as below figure). It should be confirmed beforehand whether the characteristics of the device will or will not be damaged by repairing.

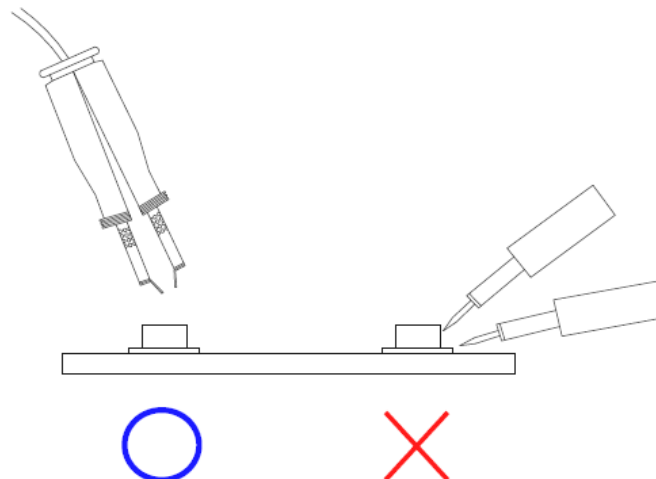

Packing Quantity Specification

3000 PCS/ 1 Reel

Label Format

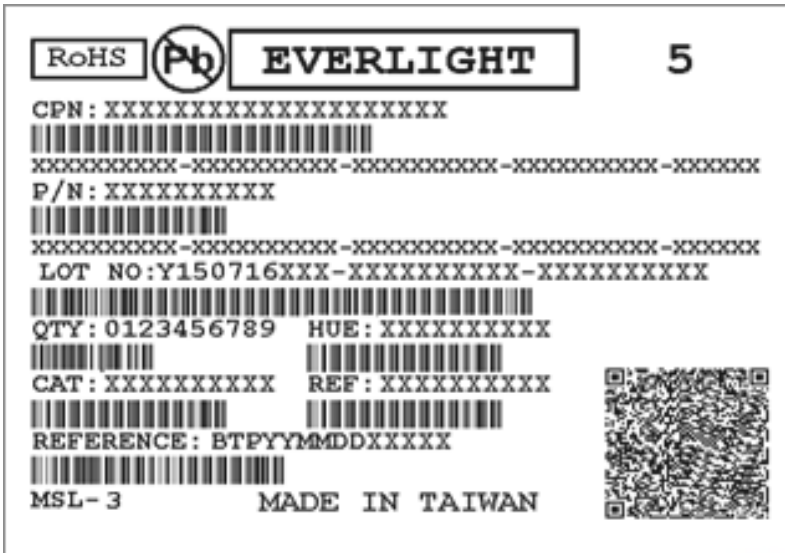

Reel Dimensions

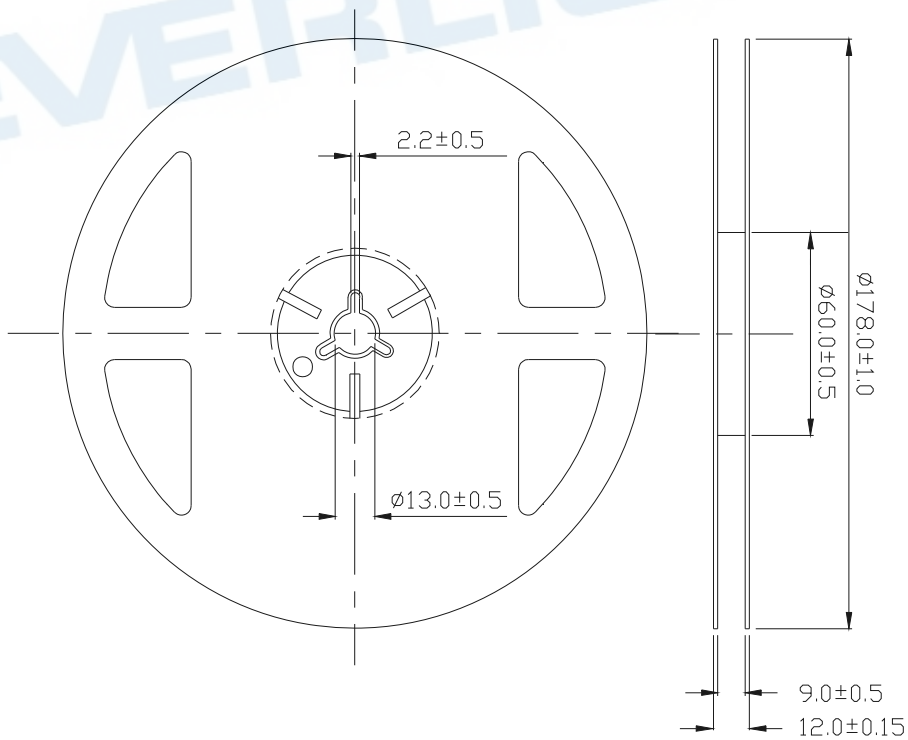

Unit: mm
 Tolerance: ±0.1mm

Tape Dimensions

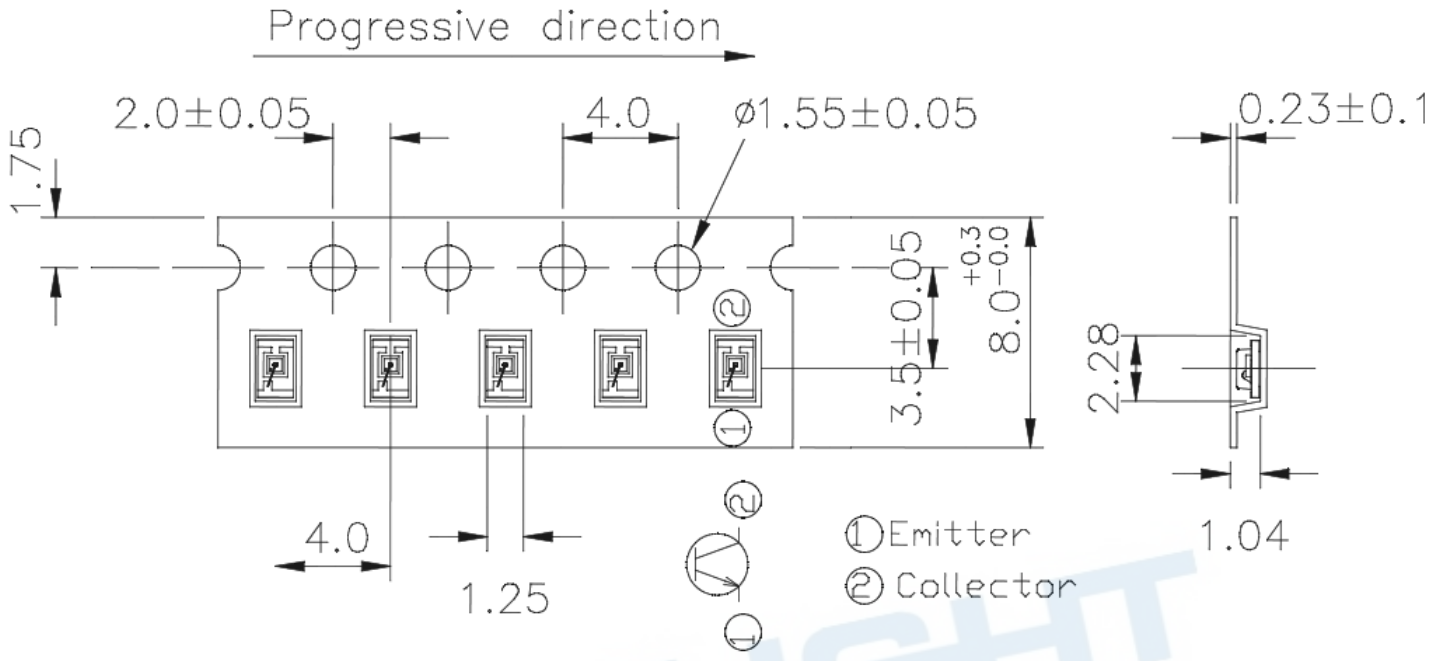

Unit: mm
Tolerance: ± 0.1 mm

DISCLAIMER

1. EVERLIGHT reserves the right(s) on the adjustment of product material mix for the specification.
2. The product meets EVERLIGHT published specification for a period of twelve (12) months from date of shipment.
3. The graphs shown in this datasheet are representing typical data only and do not show guaranteed values.
4. When using this product, please observe the absolute maximum ratings and the instructions for using outlined in these specification sheets. EVERLIGHT assumes no responsibility for any damage resulting from the use of the product which does not comply with the absolute maximum ratings and the instructions included in these specification sheets.
5. These specification sheets include materials protected under copyright of EVERLIGHT. Reproduction in any form is prohibited without obtaining EVERLIGHT's prior consent.
6. This product is not intended to be used for military, aircraft, automotive, medical, life sustaining or life saving applications or any other application which can result in human injury or death. Please contact authorized Everlight sales agent for special application request.