



Figure 1. Physical Photos of AT821

APPLICATIONS

- Sensors
- Photodiode Amplification
- Active Filters
- Test Equipment
- Driving A/D Converters

DESCRIPTION

The AT82X families of products offer low voltage operation and rail-to-rail input and output, as well as excellent speed/power consumption ratio, providing an excellent bandwidth (14MHz) and slew rate of 10V/us. The op-amps are unity gain stable and feature an ultra-low input bias current.

The devices are ideal for sensor interfaces, active filters and portable applications. The AT821S, AT822S include a shutdown mode. Under logic control, the amplifiers can be switched from normal operation to a standby current that is less than 1uA. The AT82X families of operational amplifiers are specified at the full temperature range of -40°C to +125°C under single or dual power supplies of 2.5V to 5.5V.

FEATURES

- High Gain Bandwidth: 14MHz
- Rail-to-Rail Input and Output 0.6mV Typical V_{OS}
- Input Voltage Range: -0.1V to 5.6V with $V_S = 5.5V$
- Supply Range: 2.5V to 5.5V
- Shutdown: AT821S/AT822S
- Specified Up to 125°C
- MicroSIZE PACKAGES: SOT23-5, SOT23-6

ORDERING GUIDE

Online Stores		Commission Fee	Unit Price (June 2024)	Buy Now
	shop.analogtechnologies Our own online store	Zero sale commission	\$0.59/100PCs	*
	SMTZone Our own online store	Zero sale commission	\$0.59/100PCs	*
	Digikey	≈24% sale commission	\$0.73/100PCs	*



PIN CONFIGURATIONS

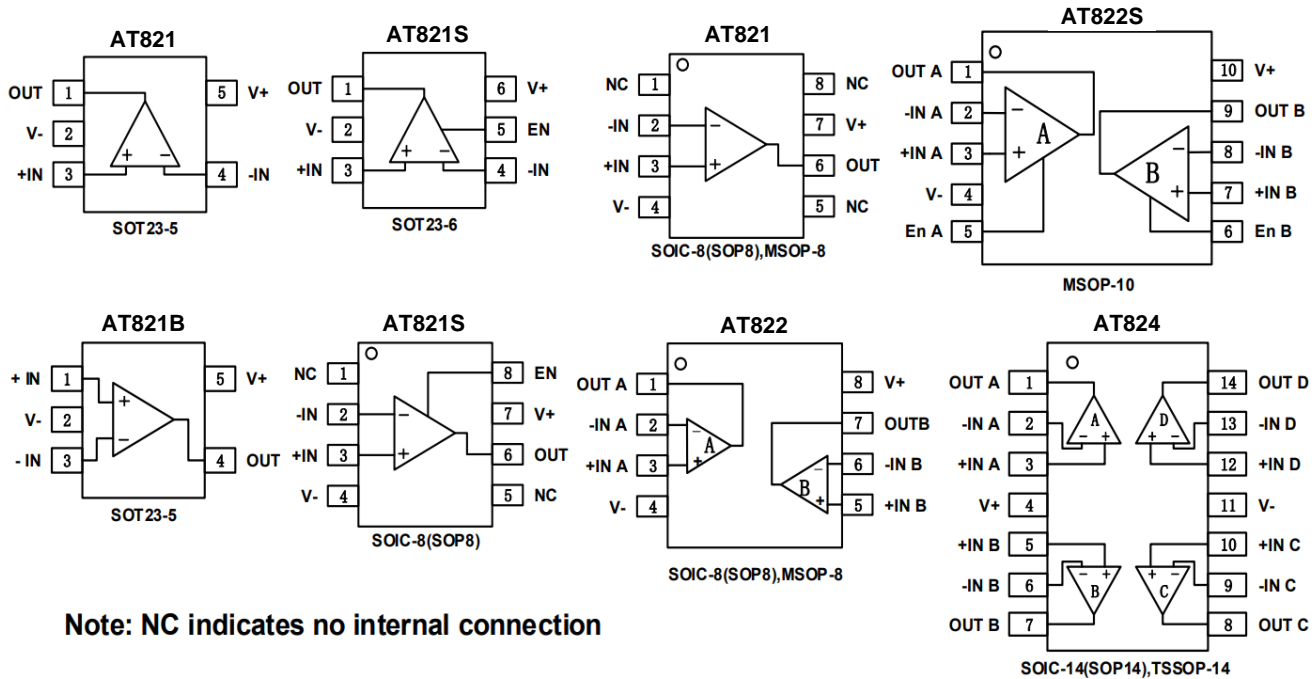

Note: NC indicates no internal connection

ABSOLUTE MAXIMUM RATINGS

Table 1.

Parameter	Rating
Supply Voltage, V+ to V-	7.0V
Input Terminals, Voltage (2)	-0.5 to (V+) + 0.5V
Input Terminals, Current (2)	±10mA
Storage Temperature	-65°C to +150°C
Operating Temperature	-40°C to +125°C
Junction Temperature	150°C
Package Thermal Resistance @ T _A = +25°C	
SOT23-5, SOT23-6	200°C/W
MSOP-10, SOIC-8	150°C/W
SOIC-16, TSSOP-14	100°C/W
MSOP-8, SOIC-8	150°C
Lead Temperature (Soldering, 10s)	260°C
ESD Susceptibility	
HBM	5000V
MM	400V

(1) Stresses above these ratings may cause ermanent damage. Exposure to absolute maximum conditions for extended periods may degrade device reliability. These are stress ratings only, and functional operation of the device at these or any other conditions beyond those specified is not implied.

(2) Input terminals are diode-clamped to the power-supply rails. Input signals that can swing more than 0.5V beyond the supply rails should be current-limited to 10mA or less.



ESD SENSITIVITY CAUTION

ESD damage can range from subtle performance degradation to complete device failure. Precision integrated circuits may be more susceptible to damage because very small parametric changes could cause the device not to meet its published specifications.



ELECTRICAL CHARACTERISTICS

(At $T_A = +25^\circ\text{C}$, $V_S = 5\text{V}$, $R_L = 10\text{k}\Omega$ connected to $V_S/2$, and $V_{OUT} = V_S/2$, unless otherwise noted.)

Table 2.

Parameter	Symbol	Test Conditions	T_J	Min.	Typ.	Max.	Unit
POWER SUPPLY							
Operating Voltage Range	V_S		25°C	2.5		5.5	V
Quiescent Current/Amplifier	I_Q		25°C		1.9	2.5	mA
Power-Supply Rejection Ratio	PSRR	$V_S = 2.5\text{V to } 5.5\text{V}$ $V_S = (V-) + 0.5\text{V}$	25°C	75	88		dB
			-40°C ~ +125°C	65			
INPUT							
Input Offset Voltage	V_{OS}		25°C		0.6	2.5	mV
Input Offset Voltage Average Drift	$V_{OS\ TC}$	-40°C ~ +125°C			1.6		$\mu\text{V}/^\circ\text{C}$
Input Bias Current	I_B		25°C		1	10	pA
Input Offset Current	I_{OS}		25°C		1	10	pA
Common-Mode Voltage Range	V_{cm}	$V_S = 5.5\text{V}$	25°C	-0.1		5.6	V
Common-Mode Rejection Ratio	CMRR	$V_S = 5.5\text{V}$, $V_{cm} = -0.1\text{V to } 4\text{V}$	25°C	75	88		dB
			-40°C ~ +125°C	67			
			25°C	61	75		
			-40°C ~ +125°C	58			
OUTPUT							
Open-Loop Voltage Gain	AOL	$R_L = 2\text{k}\Omega$, $V_O = 0.15\text{V to } 4.85\text{V}$	25°C	91	100		dB
			-40°C ~ +125°C	78			



Parameter	Symbol	Test Conditions	T _J	Min.	Typ.	Max.	Unit
		R _L =10KΩ, V _O =0.05V to 4.95V	25°C	89	98		
			-40°C ~ +125°C	75			
Output Swing From Rail		R _L =2KΩ	25°C		20		mV
		R _L =10KΩ			7		
Output Short-Circuit Current	I _{OUT}		25°C		110		mA
FREQUENCY RESPONSE							
Slew Rate	SR		25°C		10		V/μs
Gain-Bandwidth Product	GBP		25°C		14		MHz
Phase Margin	PM		25°C		58		°
Setting Time,0.1%	t _s				0.2		μs
Overload Recovery Time		V _{IN} ·Gain≥V _S			0.3		μs
NOISE							
Input Voltage Noise Density	e _n	f = 1KHz	25°C		8.5		nV/√Hz
		f = 10KHz	25°C		5.5		nV/√Hz
ENABLE/SHUTDOWN(AT821S, AT822S)							
Supply Current in Shutdown	I _{Q(OFF)}		25°C		2.7		V/μs
	t _{OFF}		25°C		4.5		MHz
	t _{ON}		25°C		1		μs
Shut Down			25°C	V-		(V-)+0.8	V
Amplifier Is Active			25°C	(V-)+2		V+	V



TYPICAL CHARACTERISTICS

At $T_A = +25^\circ\text{C}$, $V_S = 5\text{V}$, $R_{LOAD} = 10\text{k}\Omega$ connected to $V_S/2$, $V_{OUT} = V_S/2$, unless otherwise noted.

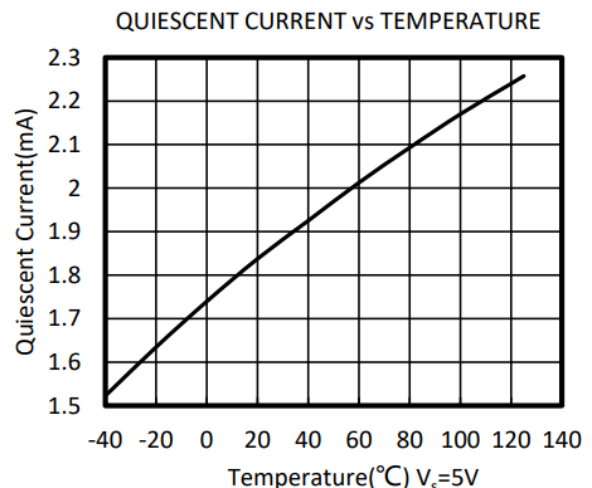
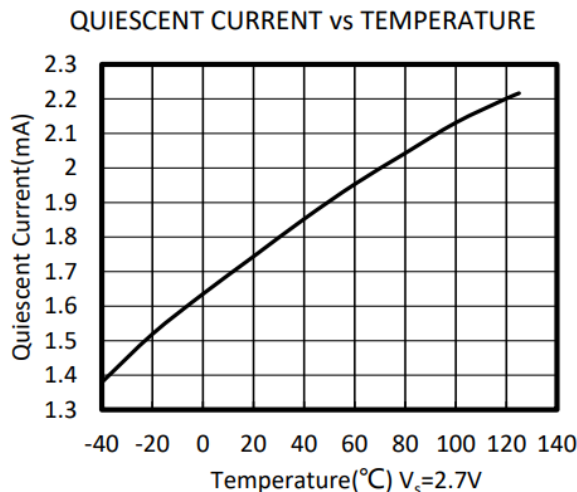
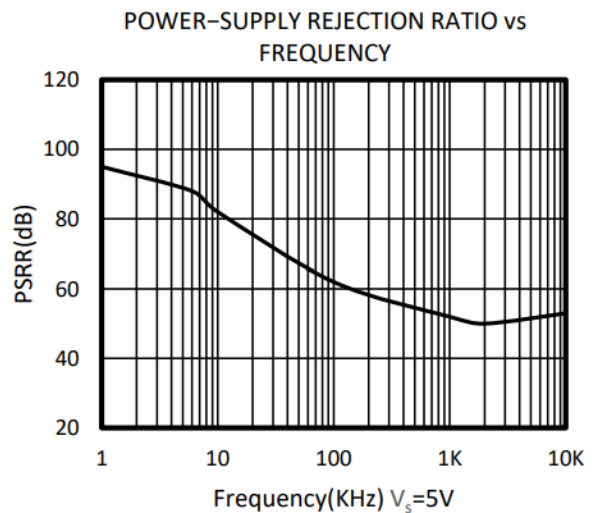
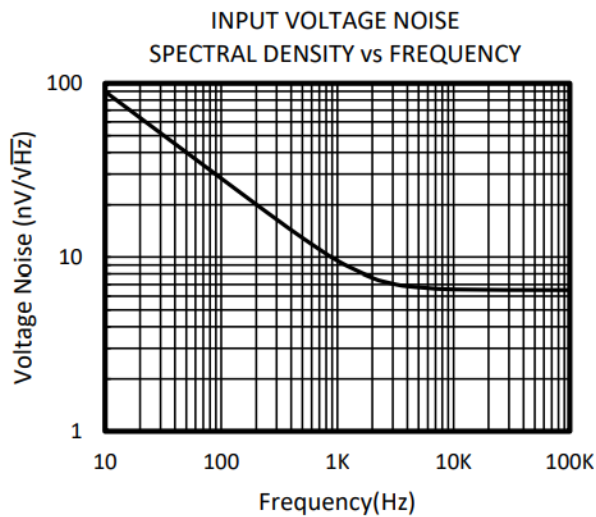
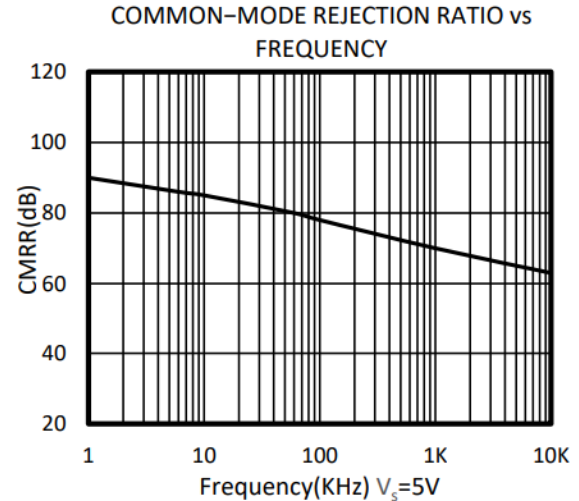
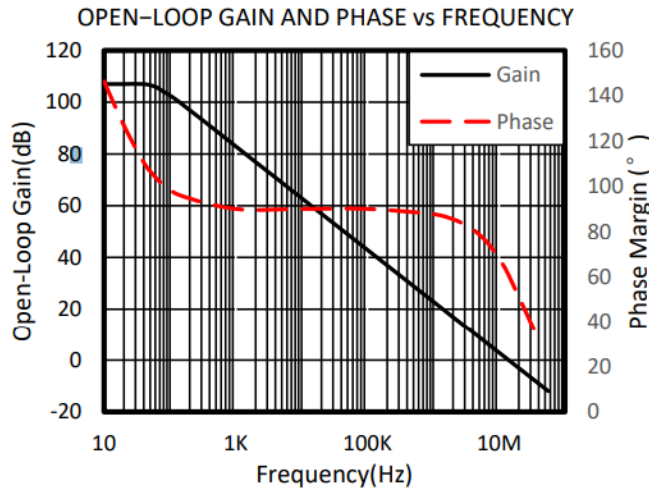

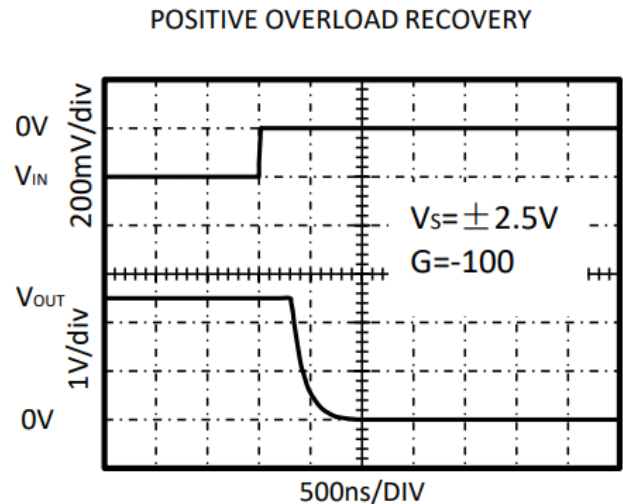
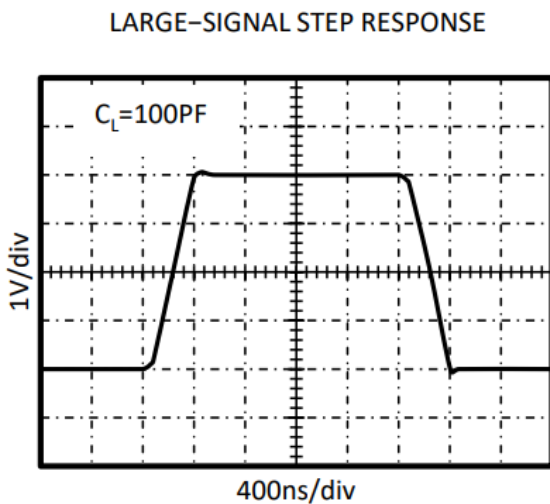
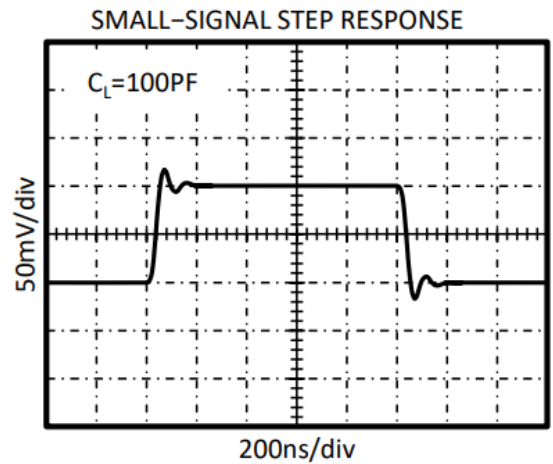
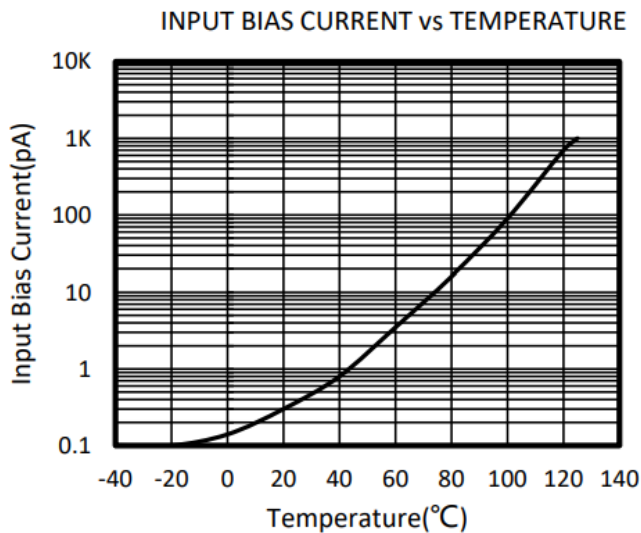
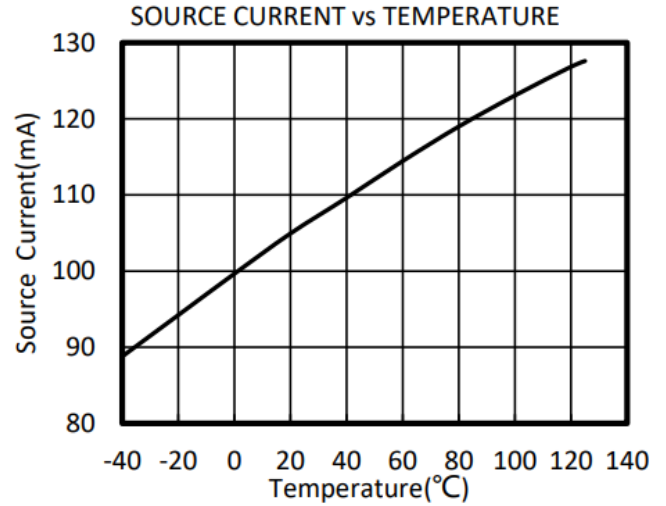
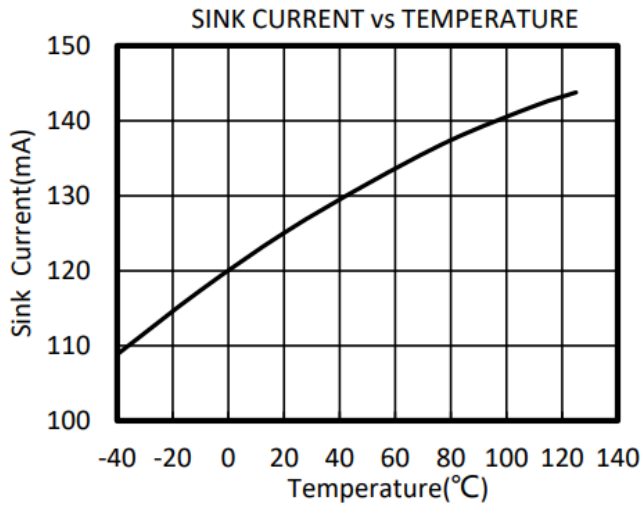

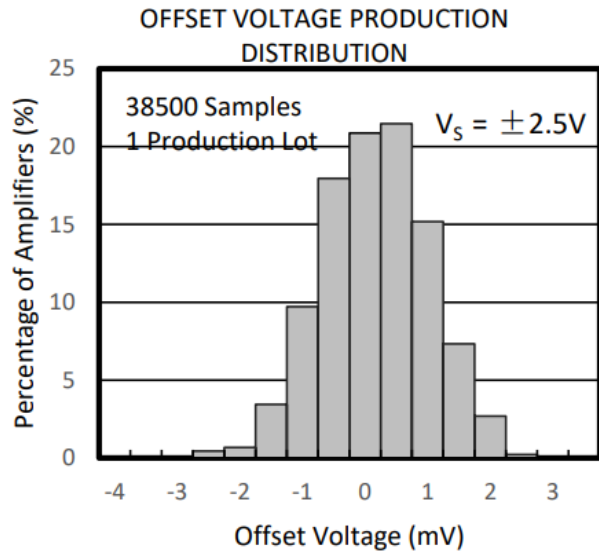
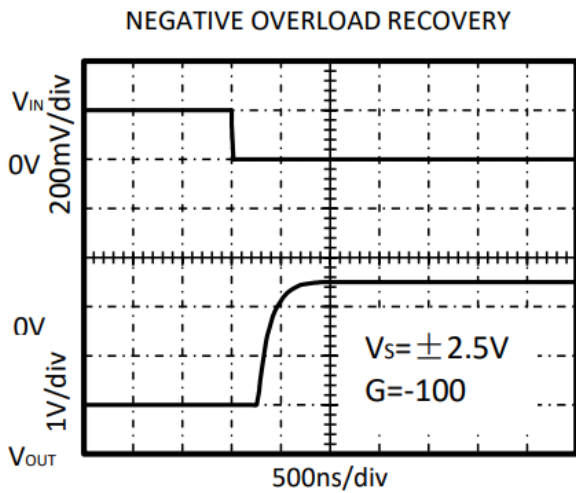

APPLICATION NOTES

The AT821, AT822, AT824, AT821S, AT822S are high precision, rail-to-rail operational amplifiers that can be run from a single-supply voltage 2.5V to 5.5V ($\pm 1.25V$ to $\pm 2.75V$). Supply voltages higher than 7V (absolute maximum) can permanently damage the amplifier.

Rail-to-rail input and output swing significantly increases dynamic range, especially in low-supply applications.

Good layout practice mandates use of a 0.1uF capacitor place closely across the supply pins.

AT821S/AT822S ENABLE FUNCTION

The AT821S/AT822S includes a shutdown mode. Under logic control, the amplifiers can be switched from normal mode to a standby current of 1uA. When the Enable pin is connected to high, the amplifier is active. Connecting Enable low disables the amplifier, and places the amplifier, and place the output in a high-impedance state.

LAYOUT GUIDELINS

Attention to good layout practices is always recommended. Keep traces short. When possible, use a PCB ground plane with surface-mount components placed as close to the device pins as possible. Place a 0.1uF capacitor closely across the

supply pins.

These guidelines should be applied throughout the analog circuit to improve performance and provide benefits such as reducing the EMI susceptibility.

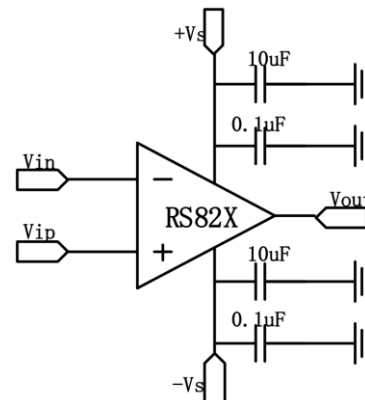

Figure 2. Amplifier with Bypass Capacitors

INSTRUMENTATION AMPLIFIER

In the three-op amp, instrumentation amplifier configuration shown in Figure 3.

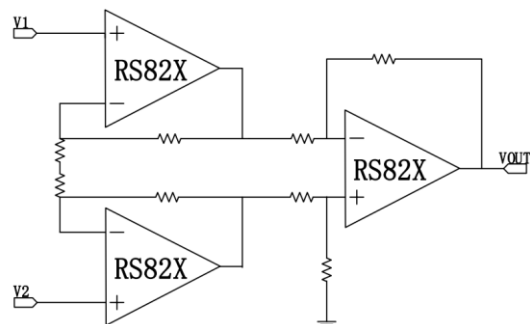
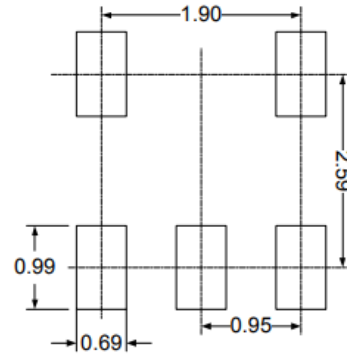
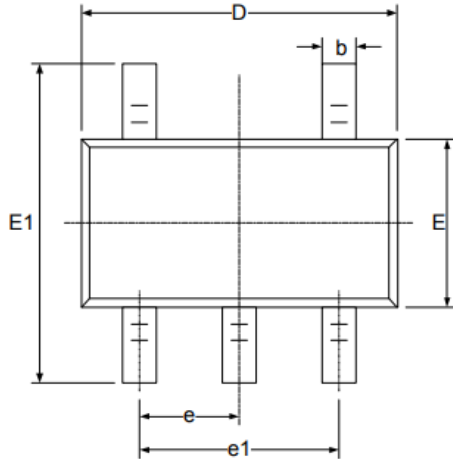

Figure 3. Amplifier Instrumentation Amplifier



OUTLINE DIMENSIONS

SOT23-5



RECOMMENDED LAND PATTERN (Unit: mm)

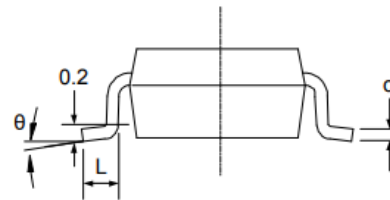
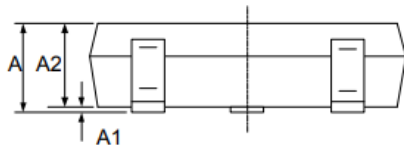

Symbol	Dimensions In Millimeters		Dimensions In Inches	
	Min	Max	Min	Max
A	1.050	1.250	0.041	0.049
A1	0.000	0.100	0.000	0.004
A2	1.050	1.150	0.041	0.045
b	0.300	0.500	0.012	0.020
c	0.100	0.200	0.004	0.008
D	2.820	3.020	0.111	0.119
E	1.500	1.700	0.059	0.067
E1	2.650	2.950	0.104	0.116
e	0.950(BSC)		0.037(BSC)	
e1	1.800	2.000	0.071	0.079
L	0.300	0.600	0.012	0.024
θ	0°	8°	0°	8°



SOT23-6

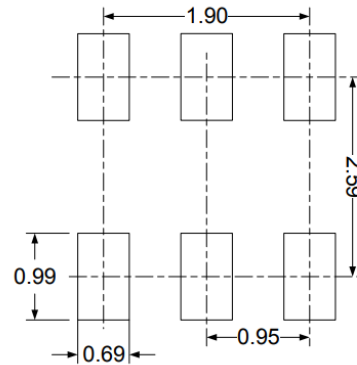
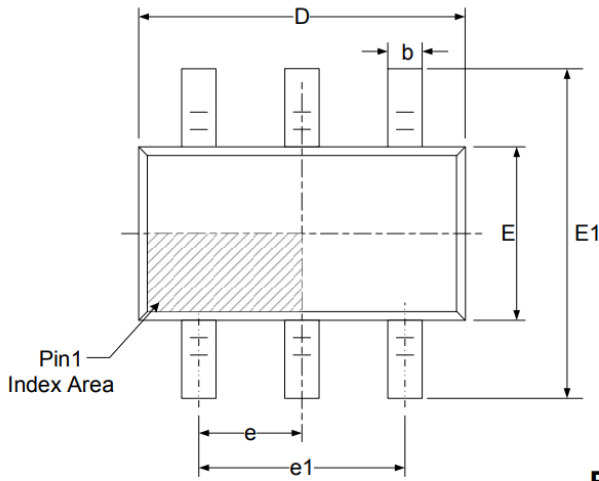

RECOMMENDED LAND PATTERN (Unit: mm)

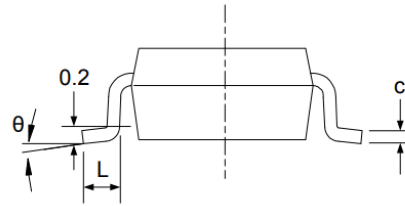
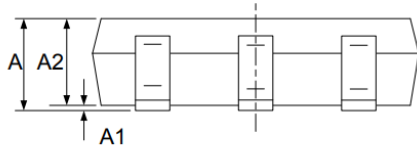

Symbol	Dimensions In Millimeters		Dimensions In Inches	
	Min	Max	Min	Max
A	1.050	1.250	0.041	0.049
A1	0.000	0.100	0.000	0.004
A2	1.050	1.150	0.041	0.045
b	0.300	0.500	0.012	0.020
c	0.100	0.200	0.004	0.008
D	2.820	3.020	0.111	0.119
E	1.500	1.700	0.059	0.067
E1	2.650	2.950	0.104	0.116
e	0.950(BSC)		0.037(BSC)	
e1	1.800	2.000	0.071	0.079
L	0.300	0.600	0.012	0.024
θ	0°	8°	0°	8°



MSOP-8

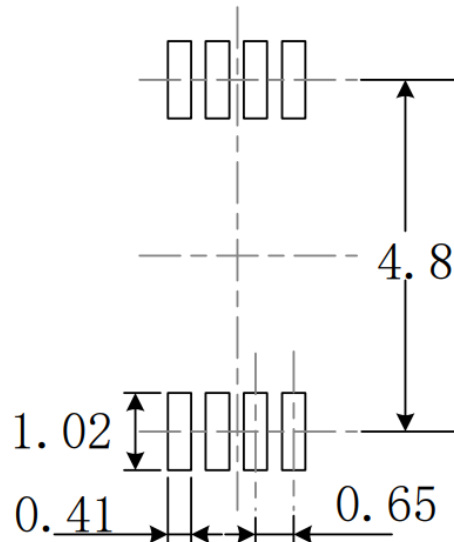
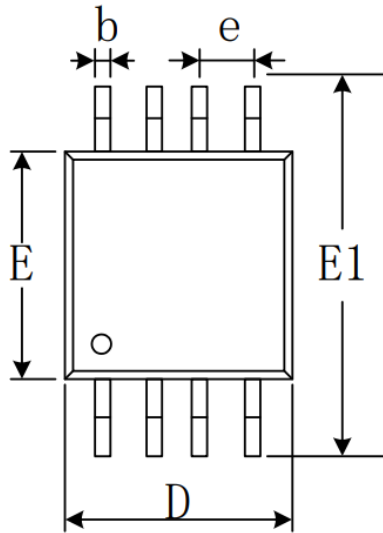

RECOMMENDED LAND PATTERN (Unit: mm)

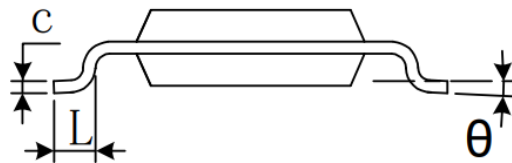
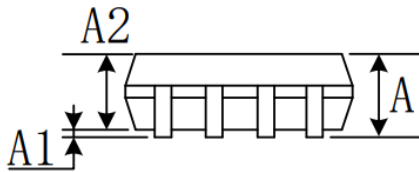

Symbol	Dimensions In Millimeters		Dimensions In Inches	
	Min	Max	Min	Max
A	0.820	1.100	0.032	0.043
A1	0.020	0.150	0.001	0.006
A2	0.750	0.950	0.030	0.037
b	0.250	0.380	0.010	0.015
c	0.090	0.230	0.004	0.009
D	2.900	3.100	0.114	0.122
e	0.650(BSC)		0.026(BSC)	
E	2.900	3.100	0.114	0.122
E1	4.750	5.050	0.187	0.199
L	0.400	0.800	0.016	0.031
θ	0°	6°	0°	6°



MSOP-10

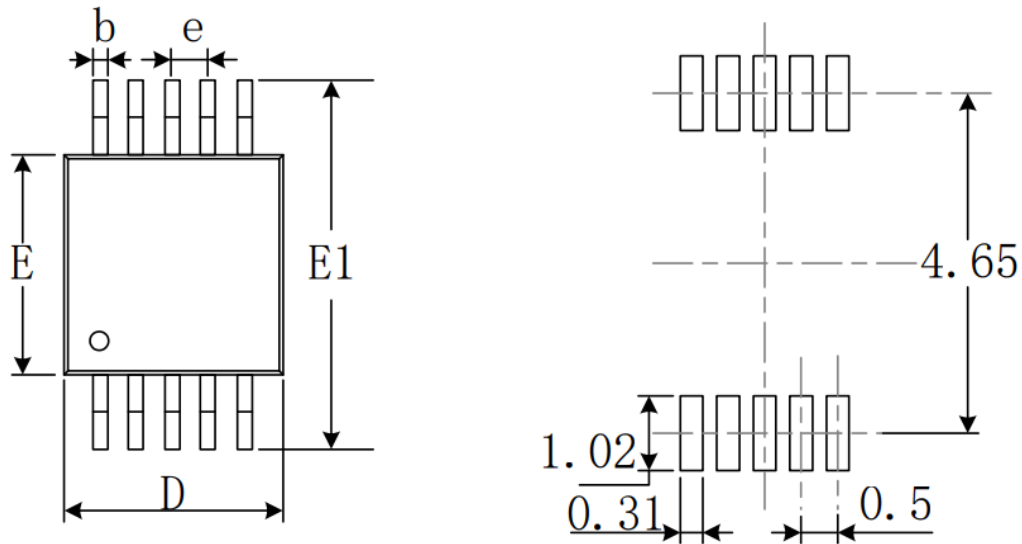

RECOMMENDED LAND PATTERN (Unit: mm)

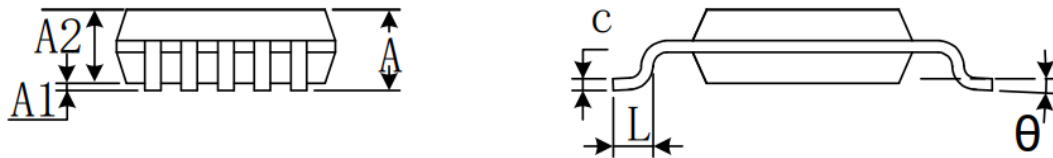

Symbol	Dimensions In Millimeters		Dimensions In Inches	
	Min	Max	Min	Max
A	0.820	1.100	0.032	0.043
A1	0.020	0.150	0.001	0.006
A2	0.750	0.950	0.030	0.037
b	0.180	0.280	0.007	0.011
c	0.090	0.230	0.004	0.009
D	2.900	3.100	0.114	0.122
e	0.50(BSC)		0.020(BSC)	
E	2.900	3.100	0.114	0.122
E1	4.750	5.050	0.187	0.199
L	0.400	0.800	0.016	0.031
theta	0°	6°	0°	6°



TSSOP-14

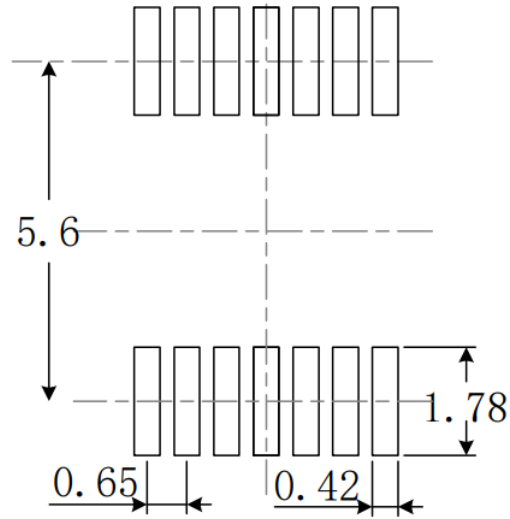
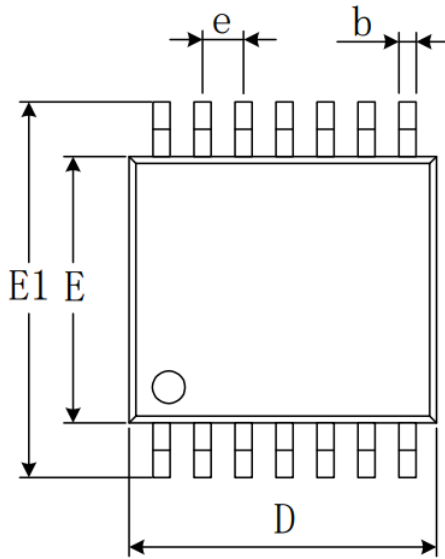

RECOMMENDED LAND PATTERN (Unit: mm)

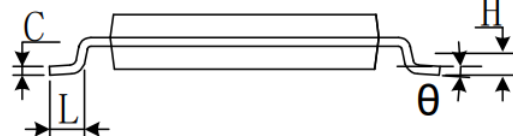
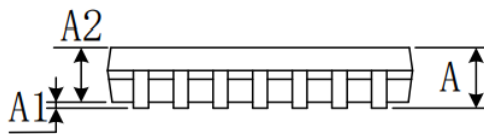

Symbol	Dimensions In Millimeters		Dimensions In Inches	
	Min	Max	Min	Max
A		1.200		0.047
A1	0.050	0.150	0.002	0.006
A2	0.800	1.050	0.031	0.041
b	0.190	0.300	0.007	0.012
c	0.090	0.200	0.004	0.008
D	4.860	5.100	0.191	0.201
E	4.300	4.500	0.169	0.177
E1	6.250	6.550	0.246	0.258
e	0.650(BSC)		0.026(BSC)	
L	0.500	0.700	0.020	0.028
H	0.25(TYP)		0.01(TYP)	
theta	1°	7°	1°	7°



SOIC-8(SOP8)

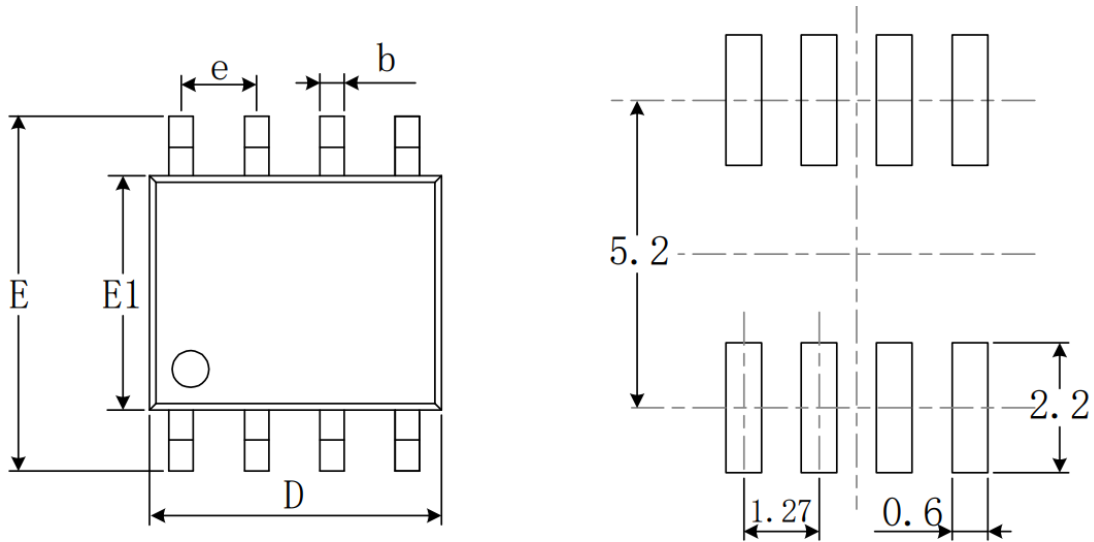

RECOMMENDED LAND PATTERN (Unit: mm)

Symbol	Dimensions In Millimeters		Dimensions In Inches	
	Min	Max	Min	Max
A	1.350	1.750	0.053	0.069
A1	0.100	0.250	0.004	0.010
A2	1.350	1.550	0.053	0.061
b	0.330	0.510	0.013	0.020
c	0.170	0.250	0.007	0.010
D	4.800	5.000	0.189	0.197
e	1.270(BSC)		0.050(BSC)	
E	5.800	6.200	0.228	0.244
E1	3.800	4.000	0.150	0.157
L	0.400	1.270	0.016	0.050
θ	0°	8°	0°	8°



SOIC-14(SOP14)

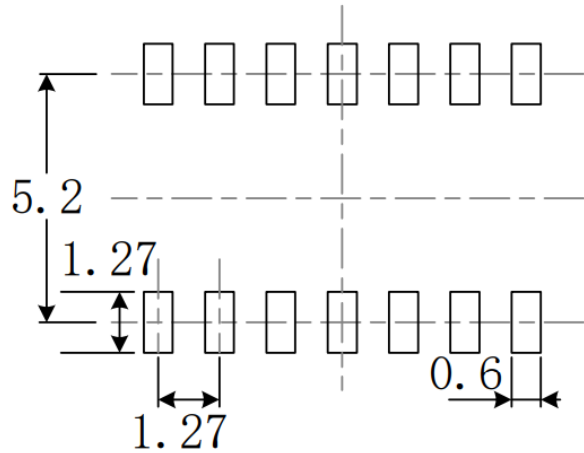
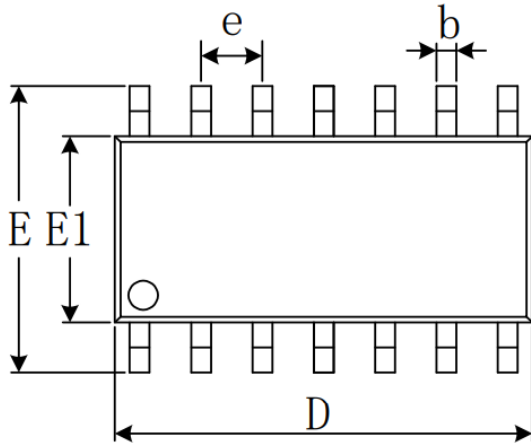

RECOMMENDED LAND PATTERN (Unit: mm)

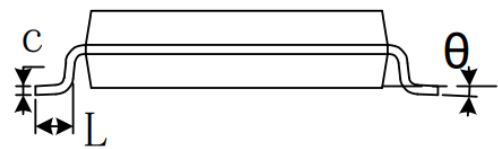
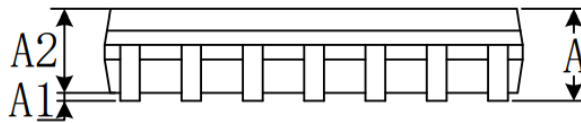

Symbol	Dimensions In Millimeters		Dimensions In Inches	
	Min	Max	Min	Max
A	1.350	1.750	0.053	0.069
A1	0.100	0.250	0.004	0.010
A2	1.350	1.550	0.053	0.061
b	0.310	0.510	0.012	0.020
c	0.100	0.250	0.004	0.010
D	8.450	8.850	0.333	0.348
e	1.270(BSC)		0.050(BSC)	
E	5.800	6.200	0.228	0.244
E1	3.800	4.000	0.150	0.157
L	0.400	1.270	0.016	0.050
θ	0°	8°	0°	8°



PACKAGE/ORDERING INFORMATION

Product	Ordering Number	Temperature Range	Package	Package Marking	Package Option
AT821	AT821XK	-40°C ~ +125°C	SOIC-8 (SOP-8)	AT821	Tape and Reel, 2500
	AT821XF	-40°C ~ +125°C	SOT23-5	821	Tape and Reel, 3000
	AT821BXF	-40°C ~ +125°C	SOT23-5	821B	Tape and Reel, 3000
	AT821XM	-40°C ~ +125°C	MSOP-8	AT821	Tape and Reel, 3000
AT821S	AT821SXK	-40°C ~ +125°C	SOIC-8 (SOP-8)	AT821S	Tape and Reel, 2500
	AT821SXH	-40°C ~ +125°C	SOT23-6	821S	Tape and Reel, 3000
AT822	AT822XK	-40°C ~ +125°C	SOIC-8 (SOP-8)	AT822	Tape and Reel, 2500
	AT822XM	-40°C ~ +125°C	MSOP-8	AT822	Tape and Reel, 3000
AT822S	AT822SXN	-40°C ~ +125°C	MSOP-10	AT822S	Tape and Reel, 3000
AT824	AT824XP	-40°C ~ +125°C	SOIC-14 (SOP-14)	AT824	Tape and Reel, 2500
	AT824XQ	-40°C ~ +125°C	TSSOP-14	AT821	Tape and Reel, 3000

ORDERING INFORMATION

Table 3. Ordering Information

Part Number	Buy Now
AT821	

*: both and are our online store icons. Our products can be ordered from either one of them with the same pricing and delivery time.

NOTICE

1. It is important to carefully read and follow the warnings, cautions, and product-specific notes provided with electronic components. These instructions are designed to ensure the safe and proper use of the component and to prevent damage to the component or surrounding equipment. Failure to follow these instructions could result in malfunction or failure of the component, damage to surrounding equipment, or even injury or harm to individuals. Always take the necessary precautions and seek professional assistance if unsure about proper use or handling of electronic components.
2. Please note that the products and specifications described in this publication are subject to change without prior notice as we continuously improve our products. Therefore, we recommend checking the product descriptions and specifications before placing an order to ensure that they are still applicable. We also reserve the right to discontinue the production and delivery of certain products, which means that not all products named in this publication may always be available.
3. This means that while ATI may provide information about the typical requirements and applications of their products, they cannot guarantee that their products will be suitable for all customer applications. It is the responsibility of the customer to evaluate whether an ATI product with the specified properties is appropriate for their particular application.



4. ATI warrants its products to perform according to specifications for one year from the date of sale, except when damaged due to excessive abuse. If a product fails to meet specifications within one year of the sale, it can be exchanged free of charge.
5. ATI reserves the right to make changes or discontinue products or services without notice. Customers are advised to obtain the latest information before placing orders.
6. All products are sold subject to terms and conditions of sale, including those pertaining to warranty, patent infringement, and limitation of liability. Customers are responsible for their applications using ATI products, and ATI assumes no liability for applications assistance or customer product design.
7. ATI does not grant any license, either express or implied, under any patent right, copyright, mask work right, or other intellectual property right of ATI.
8. ATI's publication of information regarding third-party products or services does not constitute approval, warranty, or endorsement.
9. ATI retains ownership of all rights for special technologies, techniques, and designs for its products and projects, as well as any modifications, improvements, and inventions made by ATI.
10. Despite operating the electronic modules as specified, malfunctions or failures may occur before the end of their usual service life due to the current state of technology. Therefore, it is crucial for customer applications that require a high level of operational safety, especially in accident prevention or life-saving systems where the malfunction or failure of electronic modules could pose a risk to human life or health, to ensure that suitable measures are taken. The customer should design their application or implement protective circuitry or redundancy to prevent injury or damage to third parties in the event of an electronic module malfunction or failure.