

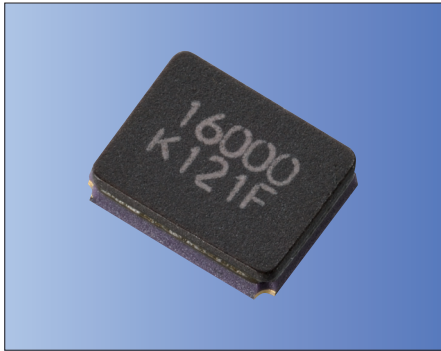

3.2 × 2.5mm for Automotive



AEC-Q200 RoHS Compliant

Features

- Crystal unit for automotive electronics
- Small and low profile (3.2 × 2.5 × 0.8mm)
- Ceramic package
- Reflow compatible

Applications

- ECU
- High-Speed Automotive Network

How to Order

CX3225CA 16000 D0 H S S HH
① ② ③ ④ ⑤ ⑥ ⑦

- ①Series
- ②Frequency
- ③Load Capacitance
- ④Frequency Tolerance
- ⑤Operating Temp. Range
- ⑥Frequency Temp. Stability
- ⑦Individual Specification (STD Standard is "HH")

Packaging (Tape & Reel 3000 pcs./ reel)

Specifications

Item	Symbol	Specification	Units	Remarks
Frequency Range	f _{nom}	12000 to 54000	kHz	
Overtone Order	OT	Fundamental	—	
Load Capacitance	CL	8	pF	Please contact us for other CL requirements.
Frequency Tolerance	f _{tol}	± 20	× 10 ⁻⁶	25° C ± 3° C
Motional Series Resistance	R1	Table 1	ohm	
Drive Level	DL	Table 2	μ W	
Operating Temp. Range	T _{use}	- 40 to +125	° C	
Storage Temp. Range	T _{stg}	- 40 to +150	° C	
Frequency Temp. Characteristics	f _{tem}	± 50	× 10 ⁻⁶	Freq. deviation from the value at 25° C

Please contact us for other specifications.

Table 1 Motional Series Resistance

Frequency Range	Motional Series Resistance
12000 ≤ f _{nom} < 13000kHz	100 Ω max.
13000 ≤ f _{nom} < 20000kHz	80 Ω max.
20000 ≤ f _{nom} ≤ 54000kHz	50 Ω max.

Table 2 Level of Drive

Frequency Range	Level of Drive
12000 ≤ f _{nom} ≤ 54000kHz	10 μ W (200 μ W max.)

Dimensions

(Unit: mm)

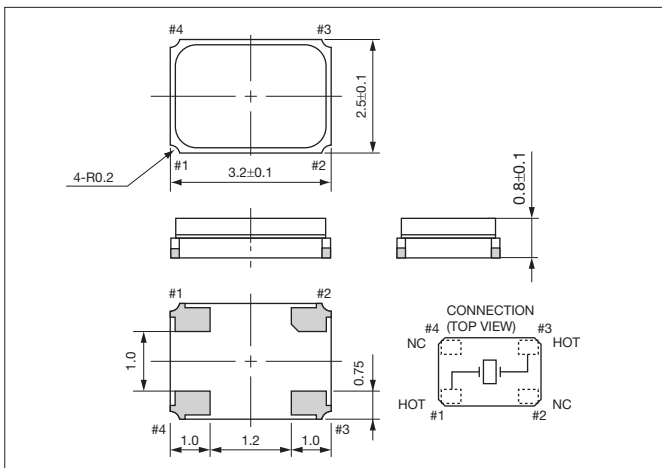

Recommended Land Pattern

(Unit: mm)

