

**Harvatek Surface Mount LED Data Sheet
HT-T169 Ultra-bright Series**

Official Product	Product: HT-T169 Ultra-bright Series			Data Sheet No.
Tentative Product	*****			HT-T169 Ultra
Specifications are subject to change without notice. Data and drawings herein are copyrighted.		July 1, 2009	Version of 2.4	Page 1/27

DISCLAIMER.....	3
PRODUCT SPECIFICATIONS	4
LABEL SPECIFICATIONS	6
PRODUCT CHARACTERISTICS.....	12
ABSOLUTE MAXIMUM RATINGS	12
ELECTRO-OPTICAL CHARACTERISTICS.....	13
PACKAGE OUTLINE DIMENSION.....	14
RECOMMENDED SOLDERING PATTERN FOR REFLOW SOLDERING	14
CHARACTERISTIC CURVES FOR URO, USD, UD, UY, UYG AND UPG	15
CHARACTERISTIC CURVES FOR NG, NBG, NB, AND TW.....	16
RADIATION PATTERN	17
PACKAGING	18
TAPE DIMENSION	18
REEL DIMENSION.....	19
PACKING	20
ATTENTION: ELECTROSTATIC DISCHARGE (ESD) PROTECTION	21
DRY PACK.....	21
REFLOW SOLDERING	22
PRECAUTIONS.....	23
REWORKING.....	23
CLEANING.....	23
RELIABILITY.....	24
APPLICATION NOTE FOR HANDLING OF COVER TAPE.....	26
REVISION HISTORY	27

Official Product	Product: HT-T169 Ultra-bright Series		Data Sheet No.
Tentative Product	*****		HT-T169 Ultra
Specifications are subject to change without notice. Data and drawings herein are copyrighted.	July 1, 2009	Version of 2.4	Page 2/27

DISCLAIMER

HARVATEK reserves the right to make changes without further notice to any products herein to improve reliability, function or design. HARVATEK does not assume any liability arising out of the application or use of any product or circuit described herein; neither does it convey any license under its patent rights, nor the rights of others.

LIFE SUPPORT POLICY

HARVATEK's products are not authorized for use as critical components in life support devices or systems without the express written approval of the President of HARVATEK or HARVATEK INTERNATIONAL. As used herein:

1. Life support devices or systems are devices or systems which, (a) are intended for surgical implant into the body, or (b) support or sustain life, and (c) whose failure to perform when properly used in accordance with instructions for use provided in the labeling, can be reasonably expected to result in a significant injury of the user.
2. A critical component in any component of a life support device or system whose failure to perform can be reasonably expected to cause the failure of the life support device or system, or to affect its safety or effectiveness.

Official Product	Product: HT-T169 Ultra-bright Series		Data Sheet No.
Tentative Product	*****		HT-T169 Ultra
Specifications are subject to change without notice. Data and drawings herein are copyrighted.	July 1, 2009	Version of 2.4	Page 3/27

Product Specifications

Product	Emission Color	Technology	Test Current I_F (mA)	Luminous Intensity I_V (mcd)	Flux Φ_V (mlm)	Orderable Part Number
HT-T169URO	Deep Red	AlInGaP	20	57.0-227.0	420 typ	HT-T169URO-YYY0
				71.5-180.0	380 typ	HT-T169URO-YYY1
				112.5-227.0	500 typ	HT-T169URO-YYY2
HT-T169UROF	Deep Red	AlInGaP	30	180.0-570.0	1110 typ	HT-T169UROF-YYY0
				180.0-450.0	950 typ	HT-T169UROF-YYY1
				285.0-570.0	1200 typ	HT-T169UROF-YYY2
HT-T169USD	Red	AlInGaP	20	90.0-360.0	665 typ	HT-T169USD-YYY0
				112.5-285.0	600 typ	HT-T169USD-YYY1
				180.0-360.0	760 typ	HT-T169USD-YYY2
HT-T169UD	Orange	AlInGaP	20	90.0-360.0	665 typ	HT-T169UD-YYY0
				112.5-285.0	600 typ	HT-T169UD-YYY1
				180.0-360.0	760 typ	HT-T169UD-YYY2
HT-T169UY	Yellow	AlInGaP	20	90.0-360.0	665 typ	HT-T169UY-YYY0
				112.5-285.0	600 typ	HT-T169UY-YYY1
				180.0-360.0	760 typ	HT-T169UY-YYY2
HT-T169UYG	Yellow Green	AlInGaP	20	45.0-112.5	240 typ	HT-T169UYG-YYY0
HT-T169UPG	Pure Green	AlInGaP	20	11.2-28.5	60 typ	HT-T169UPG-YYY0
HT-T169UPGF	Pure Green	AlInGaP	30	28.5-71.5	150 typ	HT-T169UPGF-YYY0
HT-T169NGA	True Green	InGaN	10	36.0-227.0	350 typ	HT-T169NGA-YYY0
				45.0-112.5	240 typ	HT-T169NGA-YYY1
				71.5-180.0	380 typ	HT-T169NGA-YYY2
HT-T169NG	True Green	InGaN	20	227.0-570.0	1200 typ	HT-T169NG-YYY0
HT-T169NBG	Blue Green	InGaN	20	715.0-1440.0	1200 typ	HT-T169NBG-YYY0
HT-T169NBA	Blue	InGaN	10	14.2-57.0	100 typ	HT-T169NBA-YYY0
				14.2-36.0	75 typ	HT-T169NBA-YYY1
				22.5-57.0	120 typ	HT-T169NBA-YYY2

Official Product	Product: HT-T169 Ultra-bright Series		Data Sheet No.
Tentative Product	*****		HT-T169 Ultra
Specifications are subject to change without notice. Data and drawings herein are copyrighted.		July 1, 2009	Version of 2.4
			Page 4/27

Product	Emission Color	Technology	Test Current I _F (mA)	Luminous Intensity I _V (mcd)	Flux Φ _V (mlm)	Orderable Part Number
HT-T169NB	Blue	InGaN	20	57.0-142.0	300 typ	HT-T169NB-YYY0
HT-T169TWA	White	InGaN	10	45.0-227.0	380 typ	HT-T169TWA-YYY0
				57.0-142.0	300 typ	HT-T169TWA-YYY1
				90.0-180.0	400 typ	HT-T169TWA-YYY2
HT-T169TW	White	InGaN	20	360.0-1420.0	--- typ	HT-T169TW-YYY0
				360.0-900.0	--- typ	HT-T169TW-YYY1
				900.0-1420.0	--- typ	HT-T169TW-YYY2
HT-T169TWF	White	InGaN	30	1800.0-2850.0	--- typ	HT-T169TWF-YYY0
				2850.0-4500.0	--- typ	HT-T169TWF-YYY1

Compliance and Certification

RoHS compliant and IS9002, QS9000 and ISO14001 certified.



Official Product	Product: HT-T169 Ultra-bright Series		Data Sheet No.
Tentative Product	*****		HT-T169 Ultra
Specifications are subject to change without notice. Data and drawings herein are copyrighted.	July 1, 2009	Version of 2.4	Page 5/27

Label Specifications

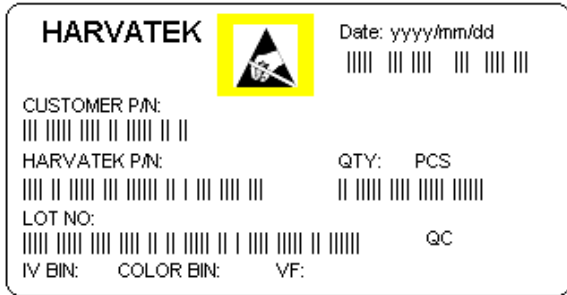

Harvatek P/N:

H T - T 1 6 9 XXXX - YYY Z

Series Name	Emitting Color	Customer Code
HT-T169 HT: Harvatek T169: tLED series 3.5 (L) x 2.7 (W) x 1.8 (H) mm	XXXX URO: Deep Red @ 20mA UROF: Deep Red @ 30mA USD: Red @ 20mA UD: Orange @ 20mA UY: Yellow @ 20mA UYG: Yellow Green @ 20mA UPG: Pure Green @ 20mA UPGF: Pure Green @ 30mA NGA: True Green @ 10mA NG: True Green @ 20mA NBG: Blue Green @ 20mA NBA: Blue @ 10mA NB: Blue @ 20mA TWA: White @ 10mA TW: White @ 20mA TWF: White @ 30mA	YYY Customer Product Code (TBD) Z 0: Luminous intensity range 0 1: Luminous intensity range 1 2: Luminous intensity range 2

Official Product	Product: HT-T169 Ultra-bright Series	Data Sheet No.
Tentative Product	*****	HT-T169 Ultra
Specifications are subject to change without notice. Data and drawings herein are copyrighted.	July 1, 2009	Version of 2.4
		Page 6/27

Lot No.:

1 2 3 4 5 6 7 8 9 10
P 1 2 2 3 0 A - D T

Code 1	Code 2	Code 3	Code 4, 5	Code 6, 7	Code 9	Code 10
	Mfg. Year	Mfg. Month	Mfg. Date	Lots	Resin Color	Packaging
Internal Tracing Code	Z: 2000 1: 2001 2: 2002 3: 2003	1: Jan. 2: Feb. 9: Sep. A: Oct. B: Nov. C: Dec.	1~31/ (30)	01~99, A,B,C...	C: Clear D: Diffused	T: Tape & Reel

Official Product	Product: HT-T169 Ultra-bright Series		Data Sheet No.
Tentative Product	*****		HT-T169 Ultra
Specifications are subject to change without notice. Data and drawings herein are copyrighted.	July 1, 2009	Version of 2.4	Page 7/27

■ Luminous Intensity (lv) Bin:

Bin	Luminous Intensity Range (mcd)		Bin	Luminous Intensity Range (mcd)	
	Minimum	Maximum		Minimum	Maximum
L1	11.2	14.2	L2	14.2	18.0
M1	18.0	22.5	M2	22.5	28.5
N1	28.5	36.0	N2	36.0	45.0
P1	45.0	57.0	P2	57.0	71.5
Q1	71.5	90.0	Q2	90.0	112.5
R1	112.5	142.0	R2	142.0	180.0
S1	180.0	227.0	S2	227.0	285.0
T1	285.0	320.0	T2	320.0	360.0
U1	360.0	400.0	U2	400.0	450.0
V1	450.0	500.0	V2	500.0	560.0
W1	560.0	630.0	W2	630.0	715.0
X1	715.0	800.0	X2	800.0	900.0
Y1	900.0	1000.0	Y2	1000.0	1125.0
Z1	1125.0	1270.0	Z2	1270.0	1440.0
AA1	1440.0	1610.0	AA2	1610.0	1800.0
AB1	1800.0	2010.0	AB2	2010.0	2250.0
AC1	2250.0	2530.0	AC2	2530.0	2850.0
AD1	2850.0	3200.0	AD2	3200.0	3600.0
AE1	3600.0	4000.0	AE2	4000.0	4500.0

Tolerance: ± 10%

Official Product	Product: HT-T169 Ultra-bright Series		Data Sheet No.
Tentative Product	*****		HT-T169 Ultra
Specifications are subject to change without notice. Data and drawings herein are copyrighted.	July 1, 2009	Version of 2.4	Page 8/27

■ Wavelength (λ_D) Bin:

Bin	Wavelength Range (nm)											
	Deep Red (URO)		Red (USD)		Orange (UD)		Yellow (UY)		Yellow Green (UYG)		Pure Green (UPG)	
	Min	Max	Min	Max	Min	Max	Min	Max	Min	Max	Min	Max
-	620.0	640.0	620.0	630								
A							582.0	585.0				
B					600.0	603.0	585.0	588.0	564.5	567.5		
C					603.0	606.0	588.0	591.0	567.5	570.5	552.5	555.5
D					606.0	609.0	591.0	594.0	570.5	573.5	555.5	558.5
E					609.0	612.0			573.5	576.5	558.5	561.5
F											561.5	564.5
G											564.5	567.5
H												

Bin	Wavelength Range (nm)					
	True Green (NG)		Blue Green (NBG)		Blue (NB)	
	Min	Max	Min	Max		
-						
A	515.0	520.0	495.0	500.0	460.0	464.0
B	520.0	525.0	500.0	505.0	464.0	468.0
C	525.0	530.0	505.0	510.0	468.0	472.0
D	530.0	535.0	510.0	515.0	472.0	476.0
E	535.0	540.0			476.0	480.0
F					480.0	485.0
H						
J						

Tolerance: $\pm 0.5\text{nm}$

Official Product	Product: HT-T169 Ultra-bright Series	Data Sheet No.
Tentative Product	*****	HT-T169 Ultra
Specifications are subject to change without notice. Data and drawings herein are copyrighted.	July 1, 2009	Version of 2.4
		Page 9/27

■ Forward Voltage (V_F) Bin:

Bin	Forward Voltage Range (V)							
	Deep Red (URO)		Bin	Red (USD), Orange (UD), Yellow (UY), Yellow Green (UYG), Pure Green (UPG)		Bin	True Green (NG), Blue Green (NBG), Blue (NB), White (TW)	
	Min	Max		Min	Max		Min	Max
-	1.6	2.4						
			E5	1.6	1.8	G8	2.7	2.9
			E6	1.8	2.0	H7	2.9	3.1
			F5	2.0	2.2	H8	3.1	3.3
			F6	2.2	2.4	J7	3.3	3.5
						J8	3.5	3.7
						K7	3.7	3.9

Tolerance: ± 0.05 V

Official Product	Product: HT-T169 Ultra-bright Series		Data Sheet No.
Tentative Product	*****		HT-T169 Ultra
Specifications are subject to change without notice. Data and drawings herein are copyrighted.	July 1, 2009	Version of 2.4	Page 10/27

■ XY Chromaticity Bin (for TW only):

	Rank A0			
x	0.280	0.264	0.283	0.296
y	0.248	0.267	0.305	0.276

	Rank B3			
x	0.287	0.283	0.304	0.307
y	0.295	0.305	0.330	0.315

	Rank B4			
x	0.307	0.304	0.330	0.330
y	0.315	0.330	0.360	0.339

	Rank C0			
x	0.330	0.330	0.361	0.356
y	0.318	0.360	0.385	0.351

	Rank B5			
x	0.296	0.287	0.307	0.311
y	0.276	0.295	0.315	0.294

	Rank B6			
x	0.311	0.307	0.330	0.330
y	0.294	0.315	0.339	0.318

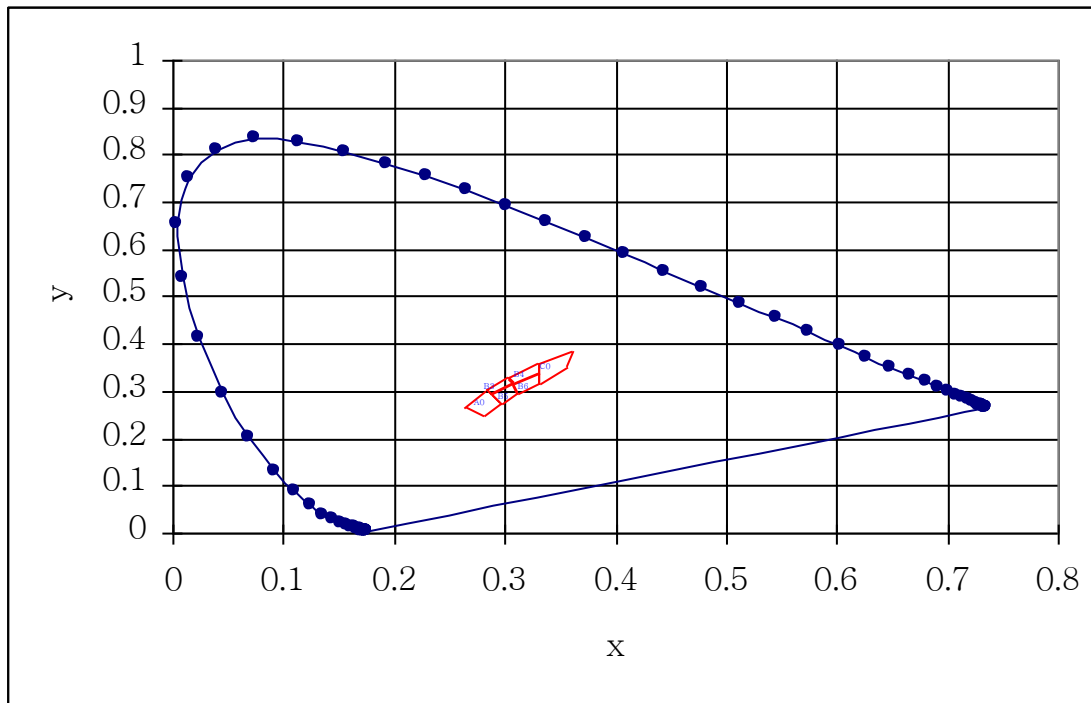

Tolerance: ± 0.01

Official Product	Product: HT-T169 Ultra-bright Series	Data Sheet No.
Tentative Product	*****	HT-T169 Ultra
Specifications are subject to change without notice. Data and drawings herein are copyrighted.	July 1, 2009	Version of 2.4
		Page 11/27

Product Characteristics

Absolute Maximum Ratings							
Product	Emission Color	P _d (mW)	I _F (mA)	I _{FP} * (mA)	V _R (V)	T _{OP} (°C)	T _{ST} (°C)
HT-T169URO	Deep Red	75	30	500	12	-40°C~+100°C	-40°C~+100°C
HT-T169UROF	Deep Red	120	50	500	12	-40°C~+100°C	-40°C~+100°C
HT-T169USD	Red	75	30	500	12	-40°C~+100°C	-40°C~+100°C
HT-T169UD	Orange	75	30	500	12	-40°C~+100°C	-40°C~+100°C
HT-T169UY	Yellow	75	30	500	12	-40°C~+100°C	-40°C~+100°C
HT-T169UYG	Yellow Green	75	30	500	12	-40°C~+100°C	-40°C~+100°C
HT-T169UPG	Pure Green	75	30	500	12	-40°C~+100°C	-40°C~+100°C
HT-T169UPGF	Pure Green	120	50	500	12	-40°C~+100°C	-40°C~+100°C
HT-T169NGA	True Green	74	20	250	5	-40°C~+100°C	-40°C~+100°C
HT-T169NG	True Green	78	20	250	5	-40°C~+100°C	-40°C~+100°C
HT-T169NBG	Blue Green	78	20	250	5	-40°C~+100°C	-40°C~+100°C
HT-T169NBA	Blue	74	20	200	5	-40°C~+100°C	-40°C~+100°C
HT-T169NB	Blue	78	20	200	5	-40°C~+100°C	-40°C~+100°C
HT-T169TWA	White	74	20	200	5	-40°C~+100°C	-40°C~+100°C
HT-T169TW	White	78	20	200	5	-40°C~+100°C	-40°C~+100°C
HT-T169TWF	White	120	30	200	5	-40°C~+100°C	-40°C~+100°C

* Condition for I_{FP} is pulse of 0.005 duty and 0.01msec width

Official Product	Product: HT-T169 Ultra-bright Series		Data Sheet No.
Tentative Product	*****		HT-T169 Ultra
Specifications are subject to change without notice. Data and drawings herein are copyrighted.		July 1, 2009	Version of 2.4
			Page 12/27

Electro-Optical Characteristics

T_a 25 °C

Product	Emission Color	I _f (mA)	V _F (V)		λ(nm)			I _v (mcd)
			typ	max	λ _D	λ _P	Δλ	Typ.
HT-T169URO	Deep Red	20	1.9	2.4	632	639	17	110
HT-T169UROF	Deep Red	30	1.9	2.4	632	639	17	300
HT-T169USD	Red	20	1.9	2.4	622	632	17	190
HT-T169UD	Orange	20	1.9	2.4	606	609	17	190
HT-T169UY	Yellow	20	1.9	2.4	587	593	15	160
HT-T169UYG	Yellow Green	20	1.9	2.4	573	574	20	70
HT-T169UPG	Pure Green	20	2.0	2.4	560	562	19	22
HT-T169UPGF	Pure Green	30	2.0	2.4	560	562	19	55
HT-T169NGA	True Green	10	3.0	3.7	532	527	30	110
HT-T169NG	True Green	20	3.3	3.9	532	527	30	400
HT-T169NBG	Blue Green	20	3.3	3.9	505	503	30	1000
HT-T169NBA	Blue	10	3.0	3.7	470	468	40	30
HT-T169NB	Blue	20	3.3	3.9	470	468	40	100
HT-T169TWA	White	10	3.1	3.7	X=0.31 Y=0.32	-	-	150
HT-T169TW	White	20	3.3	3.9	X=0.31 Y=0.32	-	-	1000
HT-T169TWF	White	30	3.3	3.9	X=0.31 Y=0.32	-	-	2000

Official Product	Product: HT-T169 Ultra-bright Series		Data Sheet No.
Tentative Product	*****		HT-T169 Ultra
Specifications are subject to change without notice. Data and drawings herein are copyrighted.	July 1, 2009	Version of 2.4	Page 13/27

Package Outline Dimension
Recommended Soldering Pattern for Reflow Soldering

Unit: mm Tolerance: +/-0.1

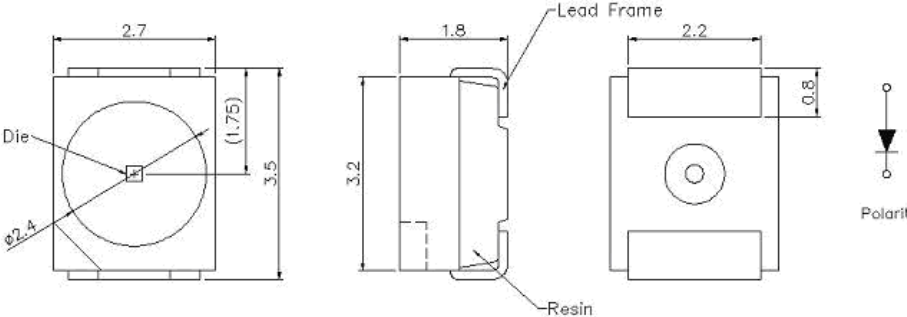
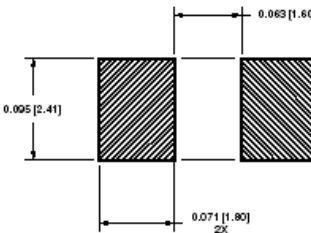
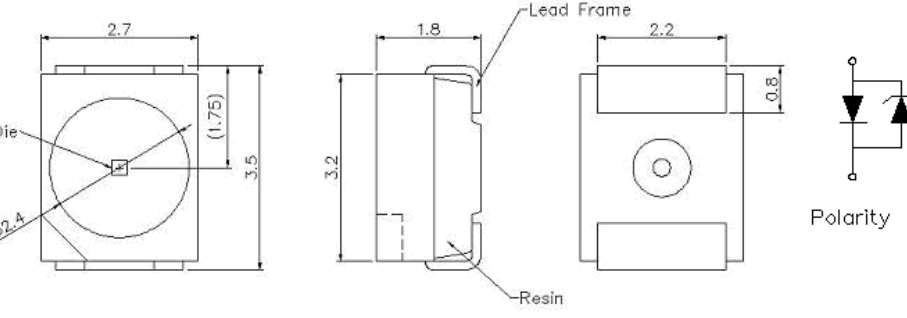
Outline Dimension	Solder Pattern
 <p style="text-align: right;">For AlInGaP</p>	
 <p style="text-align: right;">For InGaN</p>	
<p>Soldering terminals may shift in the x, y direction.</p>	<p>Unit: mm</p>

Official Product	Product: HT-T169 Ultra-bright Series		Data Sheet No.
Tentative Product	*****		HT-T169 Ultra
Specifications are subject to change without notice. Data and drawings herein are copyrighted.	July 1, 2009	Version of 2.4	Page 14/27

Characteristic Curves for URO, USD, UD, UY, UYG and UPG

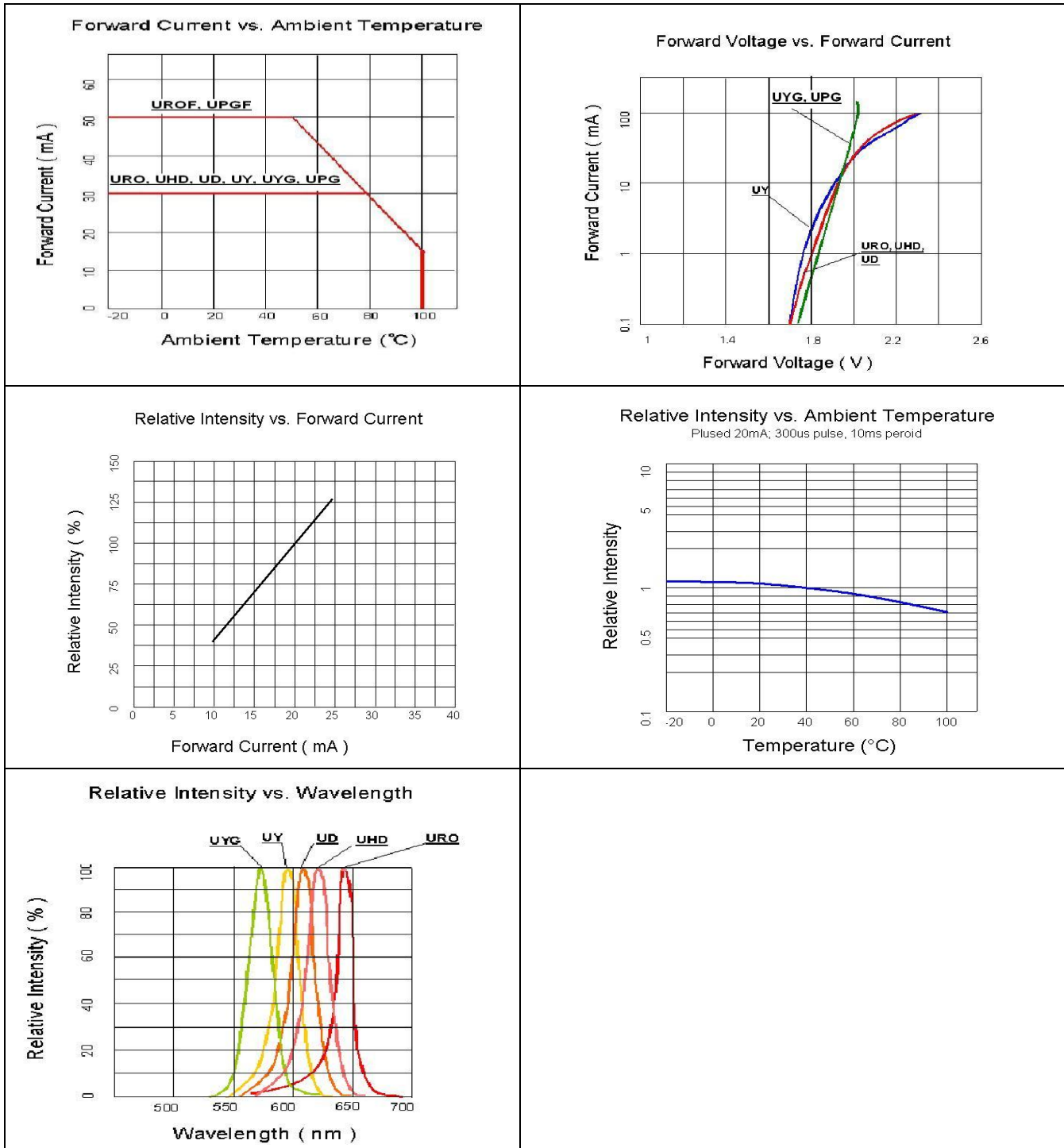

Official Product	Product: HT-T169 Ultra-bright Series	Data Sheet No.
Tentative Product	*****	HT-T169 Ultra
Specifications are subject to change without notice. Data and drawings herein are copyrighted.	July 1, 2009	Version of 2.4
		Page 15/27

Characteristic Curves for NG, NBG, NB, and TW

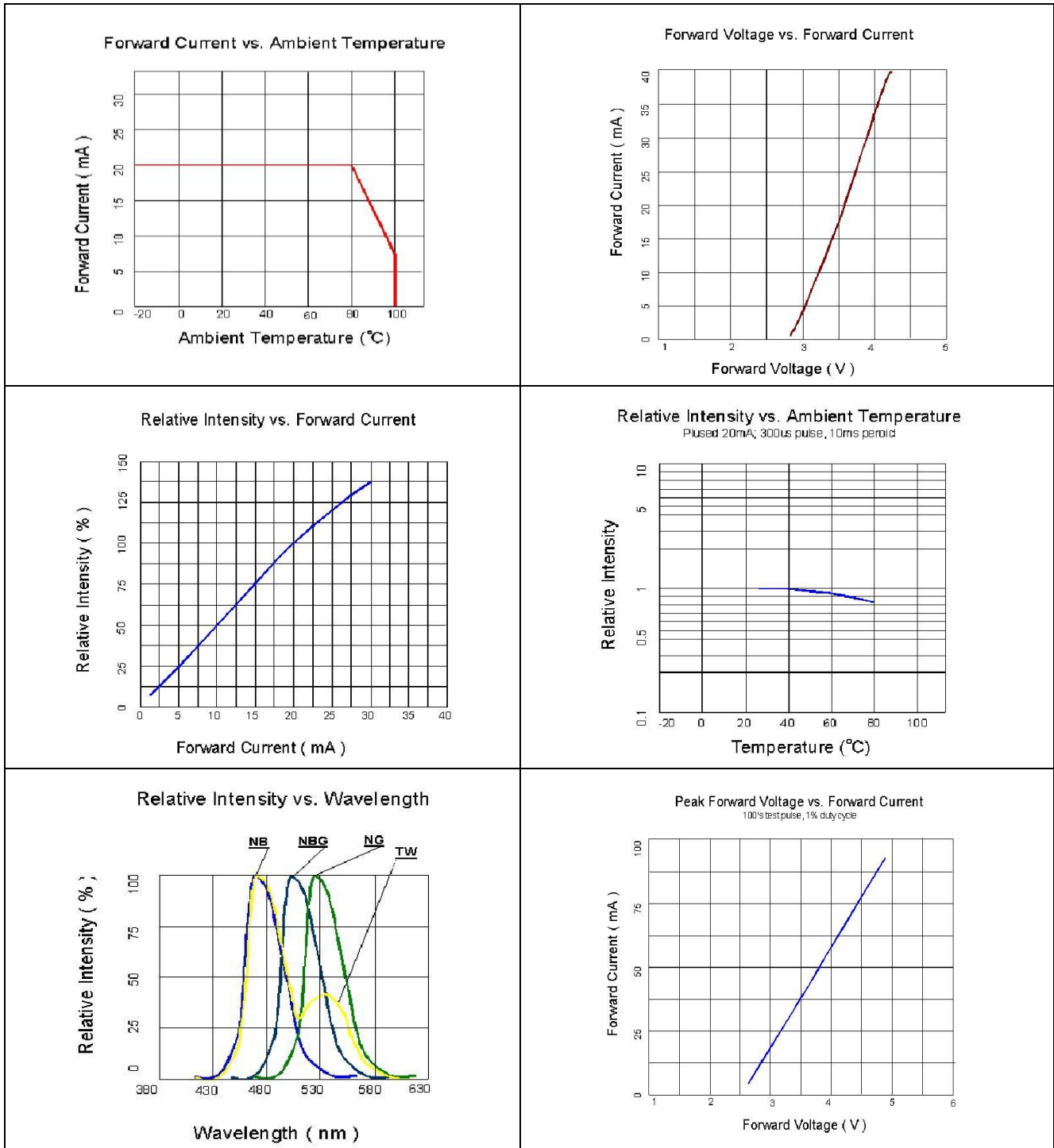

Official Product	Product: HT-T169 Ultra-bright Series	Data Sheet No.
Tentative Product	*****	HT-T169 Ultra
Specifications are subject to change without notice. Data and drawings herein are copyrighted.	July 1, 2009	Version of 2.4
		Page 16/27

Radiation Pattern

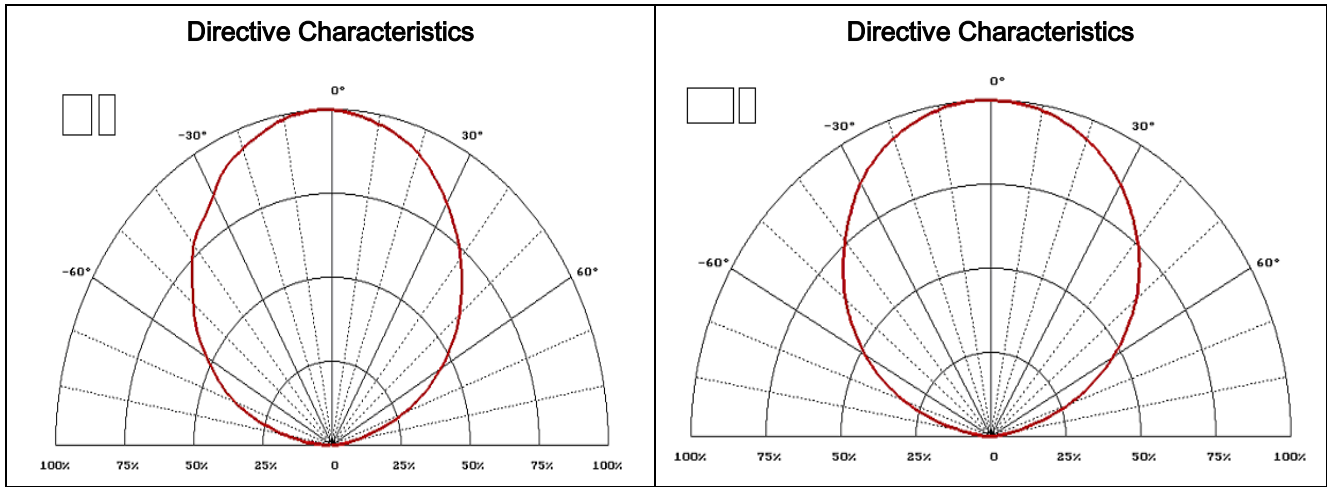

Official Product	Product: HT-T169 Ultra-bright Series		Data Sheet No.
Tentative Product	*****		HT-T169 Ultra
Specifications are subject to change without notice. Data and drawings herein are copyrighted.	July 1, 2009	Version of 2.4	Page 17/27

Packaging

Tape Dimension

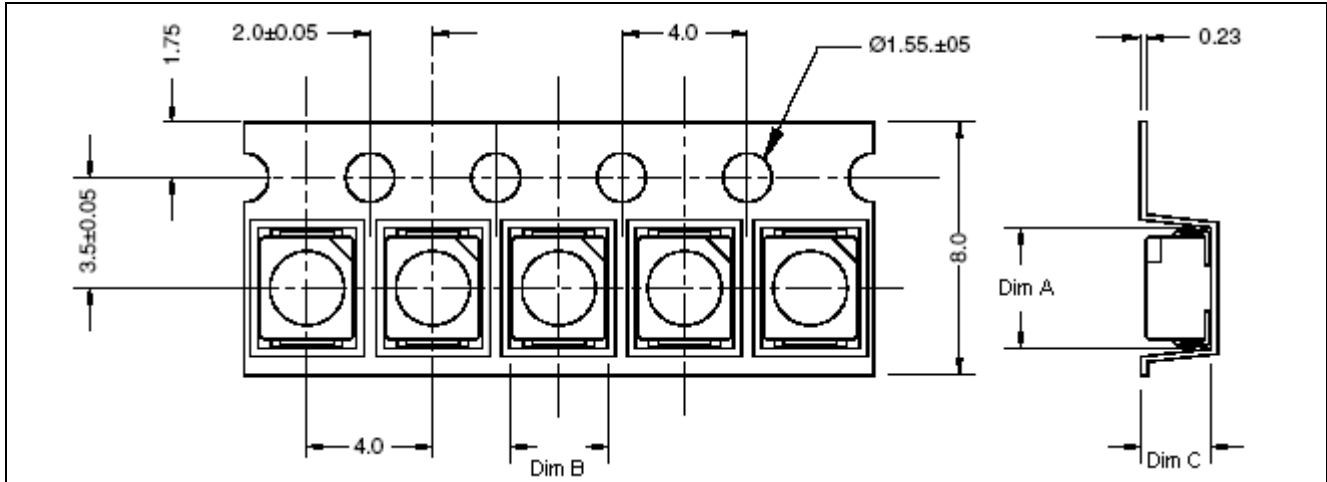

Part No.	Dim. A	Dim. B	Dim. C	Q'ty/Reel
HT-T169	3.73±0.10	2.95±0.10	2.12±0.05	2K

Unit: mm

Official Product	Product: HT-T169 Ultra-bright Series		Data Sheet No.
Tentative Product	*****		HT-T169 Ultra
Specifications are subject to change without notice. Data and drawings herein are copyrighted.	July 1, 2009	Version of 2.4	Page 18/27

Reel Dimension

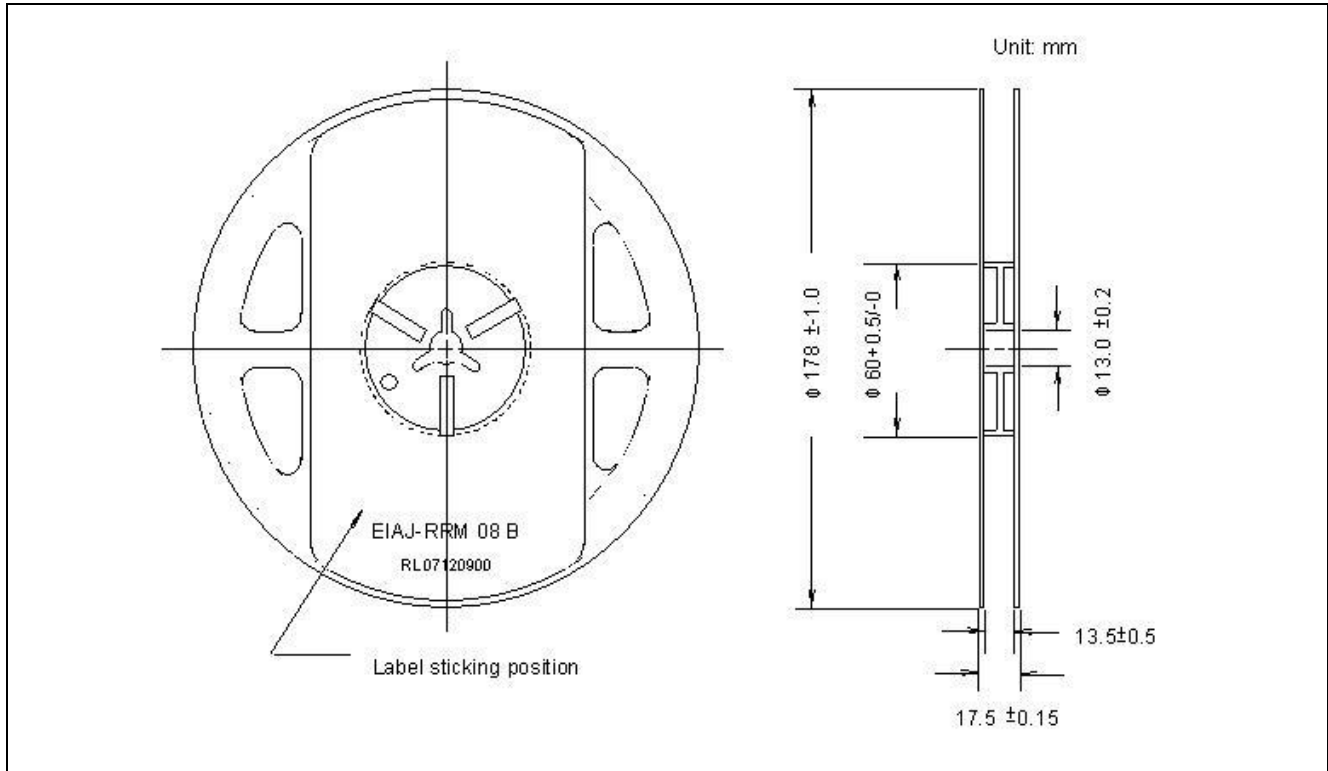

Official Product	Product: HT-T169 Ultra-bright Series	Data Sheet No.
Tentative Product	*****	HT-T169 Ultra
Specifications are subject to change without notice. Data and drawings herein are copyrighted.	July 1, 2009	Version of 2.4
		Page 19/27

Packing

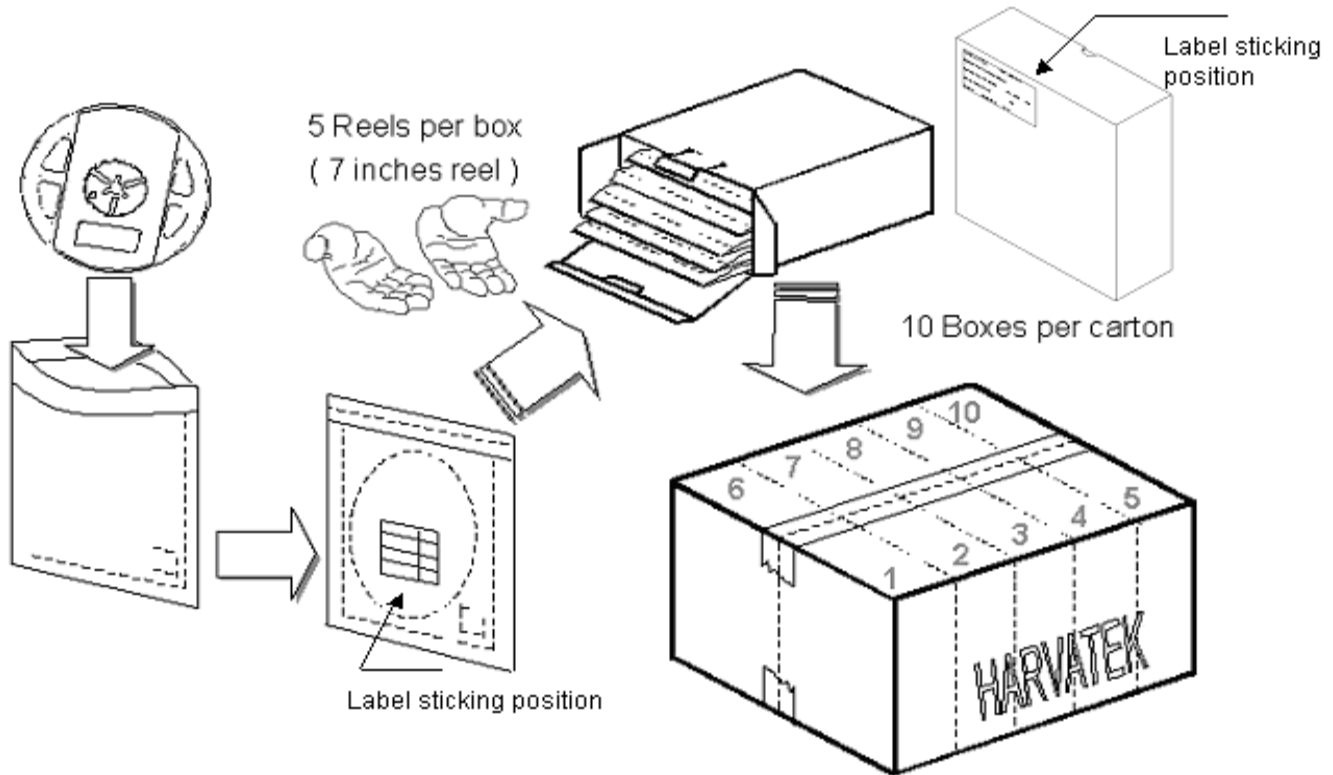

5 boxes per carton are available depending on shipment quantity.

	Specification	Material	Quantity
Carrier tape	Per EIA 481-1A specs	Plastic tape	2000pcs per reel
Reel	Per EIA 481-1A specs	Plastic white	
Label	HT standard	Paper	
Packing bag	220x240mm	Aluminum laminated bag/ no-zipper	One reel per bag
Carton	HT standard	Paper	Non-specified

Others:

Each immediate box consists of 5 reels. The 5 reels may not necessarily have the same lot number or the same bin combinations of Iv, λD and Vf. Each reel has a label identifying its specification; the immediate box consists of a product label as well.

Official Product	Product: HT-T169 Ultra-bright Series	Data Sheet No.
Tentative Product	*****	HT-T169 Ultra
Specifications are subject to change without notice. Data and drawings herein are copyrighted.	July 1, 2009	Version of 2.4
		Page 20/27

ATTENTION: Electrostatic Discharge (ESD) protection



The symbol to the left denotes that ESD precaution is needed. ESD protection for GaP and AlGaAs based chips is necessary even though they are relatively safe in the presence of low static-electric discharge. Parts built with AlInGaP, GaN, or/and InGaN based chips are **STATIC SENSITIVE devices**. ESD precaution must be taken during design and assembly. If manual work or processing is needed, please ensure the device is adequately protected from ESD during the process.

Dry Pack

All SMD optical devices are **MOISTURE SENSITIVE**. Avoid exposure to moisture at all times during transportation or storage. Every reel is packaged in a moisture protected anti-static bag. Each bag is properly sealed prior to shipment.

Upon request, a humidity indicator will be included in the moisture protected anti-static bag prior to shipment.

The packaging sequence is as follows:

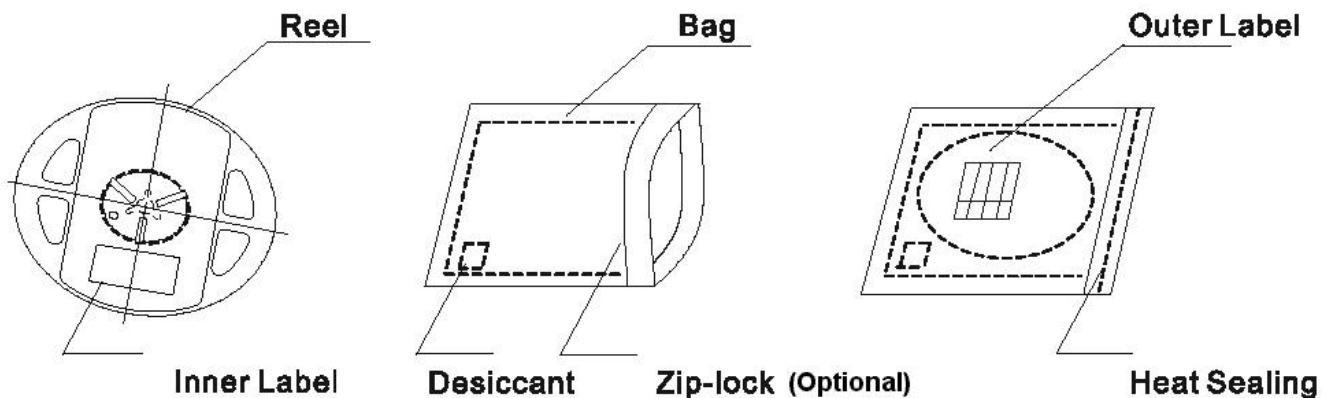

Official Product	Product: HT-T169 Ultra-bright Series		Data Sheet No.
Tentative Product	*****		HT-T169 Ultra
Specifications are subject to change without notice. Data and drawings herein are copyrighted.	July 1, 2009	Version of 2.4	Page 21/27

Reflow Soldering

- Recommended tin glue specifications: melting temperature in the range of 178~192 °C
- The recommended reflow soldering profile is as follows (temperatures indicated are as measured on the surface of the LED resin):

Lead Solder Profile

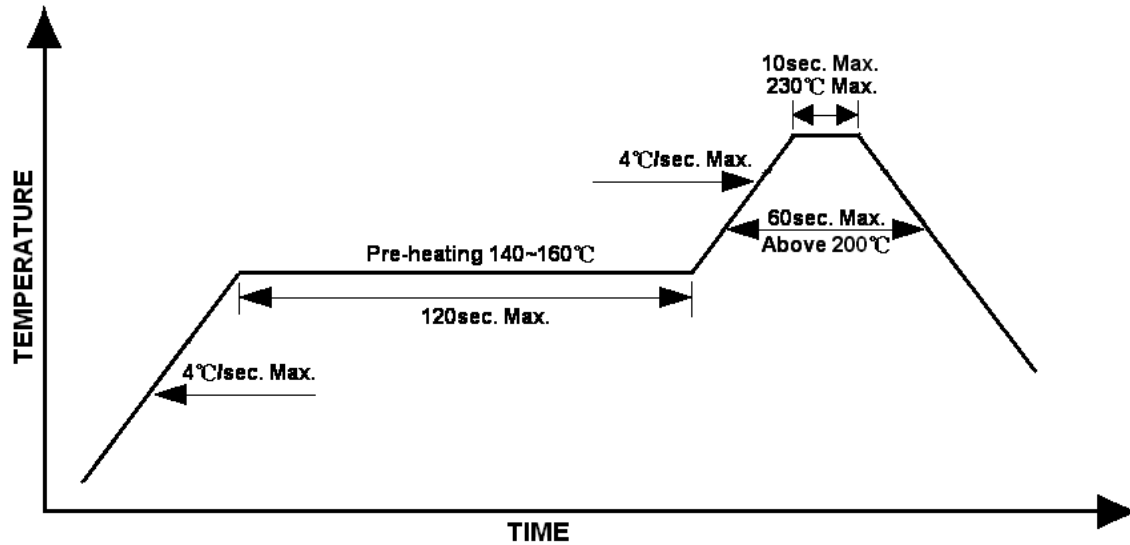

Lead-free Solder Profile

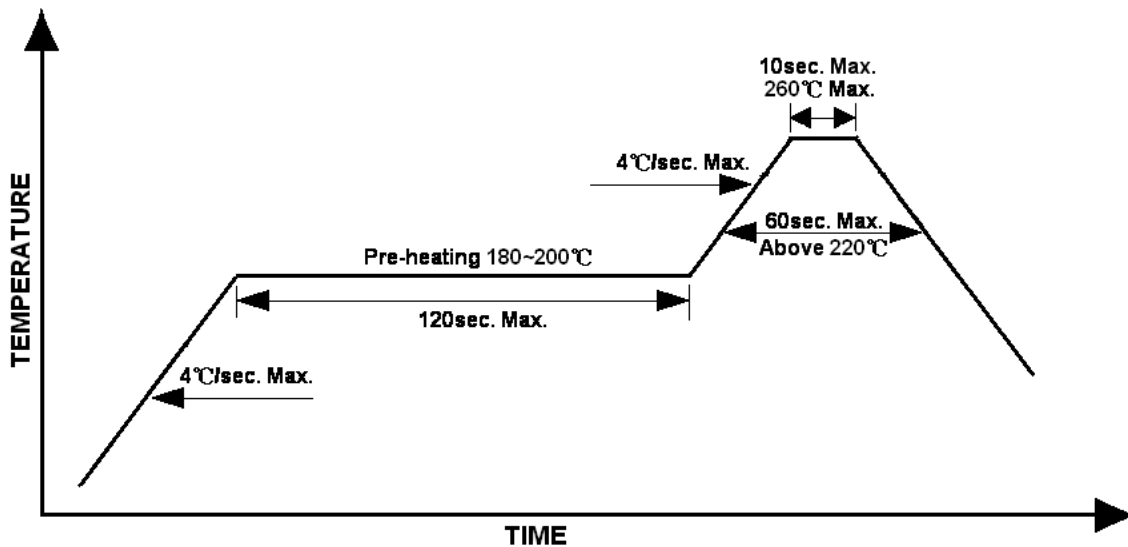

Official Product	Product: HT-T169 Ultra-bright Series	Data Sheet No.
Tentative Product	*****	HT-T169 Ultra
Specifications are subject to change without notice. Data and drawings herein are copyrighted.	July 1, 2009	Version of 2.4
		Page 22/27

Precautions

1. Avoid exposure to moisture at all times during transportation or storage.
2. Anti-Static precaution must be taken when handling GaN, InGaN, and AlInGaP products.
3. It is suggested to connect the unit with a current limiting resistor of the proper size. Avoid applying a reverse voltage beyond the specified limit.
4. Avoid operation beyond the limits as specified by the absolute maximum ratings.
5. Avoid direct contact with the surface through which the LED emits light.
6. If possible, assemble the unit in a clean room or dust-free environment.

Reworking

- Rework should be completed within 5 seconds under 260 °C.
- The iron tip must not come in contact with the copper foil.
- Twin-head type is preferred.

Cleaning

Following are cleaning procedures after soldering:

- An alcohol-based solvent such as isopropyl alcohol (IPA) is recommended.
- Temperature x Time should be 50°C x 30sec. or <30°C x 3min
- Ultra sonic cleaning: < 15W/ bath; bath volume ≤ 1liter
- Curing: 100 °C max, <3min

Cautions of Pick and Place

- Avoid stress on the resin at elevated temperature.
- Avoid rubbing or scraping the resin by any object.
- Electro-static may cause damage to the component. Please ensure that the equipment is properly grounded. Use of an ionizer fan is recommended.

Official Product	Product: HT-T169 Ultra-bright Series		Data Sheet No.
Tentative Product	*****		HT-T169 Ultra
Specifications are subject to change without notice. Data and drawings herein are copyrighted.	July 1, 2009	Version of 2.4	Page 23/27

Reliability

Package Reliability Test

Test Item	Test Condition	Note	Sample size
Solder Heat Resistance I	260°C, 10sec, once	Dip Soldering	22
Solder Heat Resistance II	240°C, 10sec, twice (Storage:30°C, 60%RH, 168h)	Reflow Soldering	77
Solderability	230°C, 5sec, once	>90% (using flux)	22
Vibration	100-2000Hz/20G, 4 min-sweep Three directions (X, Y, Z), 5 times each		40
Shock	1500G, Three directions (X, Y, Z), 5 times each		40
Drop	1m		40
Temperature Cycling	-40°C/15 min, 25°C/5 min, 100°C/15 min	300 cycles	77
High Temperature Storage	Ta = 100°C	1000h	77
Low Temperature Storage	Ta = -40°C	1000h	77
High Temp/Humidity Storage	Ta = 60°C, RH = 90%	1000h	77
Electrostatic Discharge	R = 1.5k., C = 100pF, Test voltage = 2KV	3 times, -/+	40
COQ		300 cycles	300
PCT		96h	100
JEDEC Level I			100

Life Test I (for HT-T169UPG / UYG / UY / UD / USD / USD / URO)

Test Item	Test Condition	Note	Sample size
Steady State Operation	IF = 50mA , Ta = 25°C	1000h	40
High Temperature Operation	IF = 20mA, Ta = 85°C	1000h	40
Low Temperature Operation	IF = 20mA, Ta = -40°C	1000h	40
High Temp/Humidity Operation	IF = 20mA, Ta = 60°C, RH=90%	1000h	40

Official Product	Product: HT-T169 Ultra-bright Series		Data Sheet No.
Tentative Product	*****		HT-T169 Ultra
Specifications are subject to change without notice. Data and drawings herein are copyrighted.	July 1, 2009	Version of 2.4	Page 24/27

Life Test II (for HT-T169NB / NG / TW)

Test Item	Test Condition	Note	Sample size
Steady State Operation	IF = 30mA , Ta = 25°C	1000h	40
High Temperature Operation	IF = 10mA, Ta = 85°C	1000h	40
Low Temperature Operation	IF = 10mA, Ta = -40°C	1000h	40
High Temp/Humidity Operation	IF = 10mA, Ta = 60°C, RH=90%	1000h	40

Criteria for Judging the Damage

Item	Symbol	Test Condition	Criteria for Judgement	
			Min.	Max.
Forward Voltage	Vf	I _F = 20mA	-	U.S. L x 1.2
Luminous Intensity	Iv	I _F = 20mA	L.S.L.x 0.5	

*) U.S.L.: Upper Standard Level

***) L.S.L.: Lower Standard Level

Official Product	Product: HT-T169 Ultra-bright Series		Data Sheet No.
Tentative Product	*****		HT-T169 Ultra
Specifications are subject to change without notice. Data and drawings herein are copyrighted.	July 1, 2009	Version of 2.4	Page 25/27

Application Note for Handling of Cover Tape

When cover tape was removed from carrier tape during pick and place process, PSA cover tape adhesive may incur build up on the feeder track, gear or even inside the trash box. (As long as equipment part that has contact with the cover tape during removal process).

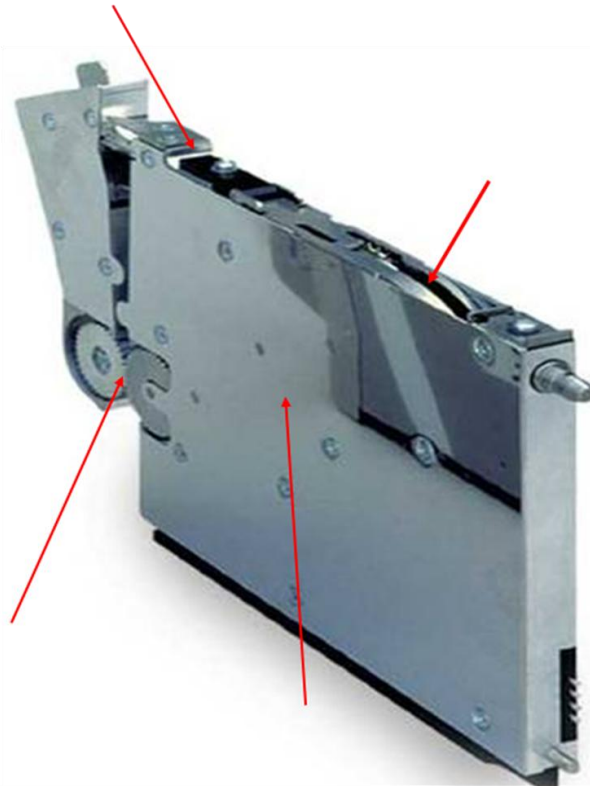

- 1) 3M Adhesive Remover can be used to remove adhesive effectively
- 2) 3M 5490 PTFE film is recommended to be applied on the part that is in contact with the PSA cover tape adhesive.

PS: For more detail application instruction, 3M requests a close up picture at the feeders portion as indicated with red arrow. Please take picture when the tape is put on with cover tape removal from the tape.

Official Product	Product: HT-T169 Ultra-bright Series		Data Sheet No.
Tentative Product	*****		HT-T169 Ultra
Specifications are subject to change without notice. Data and drawings herein are copyrighted.	July 1, 2009	Version of 2.4	Page 26/27

Revision History

Changes since last revision	Page	Version No.	Revision Date
Initial Release		1.0	05-02-2005
Data Sheet No. & Page Numbering	All	1.1	05-31-2005
Reliability data	23-24	1.2	06-06-2005
Tape dimension; carrier tape and reel material	17,19	1.3	07-05-2005
Wavelength bin codes for UPG	8	1.4	07-11-2005
Remove condition for tolerance	7-10	1.5	07-21-2005
RoHS Compliance and Certification		1.6	09-21-2006
White spec updated		1.7	11-30-2006
Revision for brightness & XY color bin		1.8	12-28-2006
Revise Polarity as per cathode mark		1.9	3-28-2007
Revise Iv for NBG	4, 13	2.0	6-18-2008
Add Application Note	26	2.1	08-13-2008
Add InGaN Drawing	14	2.2	12-04-2008
Update spec		2.3	04-14-2009
Update spec to include HT-T169TWF		2.4	07-01-2009

Official Product	Product: HT-T169 Ultra-bright Series		Data Sheet No.
Tentative Product	*****		HT-T169 Ultra
Specifications are subject to change without notice. Data and drawings herein are copyrighted.	July 1, 2009	Version of 2.4	Page 27/27