

GaN Power Transistor 28 V, 23 W DC - 3 GHz



NPT25015
Rev. V2

Features

- Optimized for CW, pulsed, WiMAX, and other applications from DC - 3000 MHz
- 23 W P3dB peak envelope power (PEP)
- 1.5 W linear power @ 2% EVM for single carrier OFDM, 10.3 dB peak/average, 3.5 MHz channel bandwidth, 14 dB gain, 23.5% efficiency, 2500-2700 MHz
- 100% RF tested
- Thermally-enhanced industry standard package
- High reliability gold metallization process
- Lead-free and RoHS compliant
- Subject to EAR99 export control

Applications

- Defense Communications,
- Land Mobile Radio,
- Avionics,
- Wireless Infrastructure,
- ISM
- VHF/UHF/L/S-Band Radar.

Description

The NPT25015 GaN HEMT is a power transistor optimized for DC - 3 GHz operation. This device supports CW, pulsed, and linear operation with output power levels to 23 W. This transistor is assembled in an industry standard surface mount plastic package.

Ordering Information

Part Number	Package
NPT25015D	Tube (95 pieces)
NPT25015DR	1500 piece reel

Functional Schematic

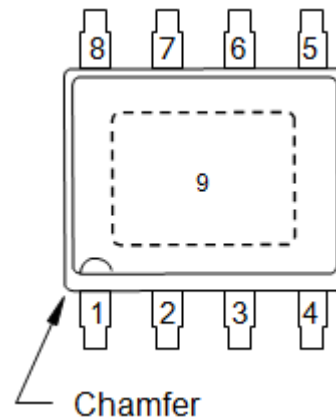

Pin Configuration

Pin #	Function
1 - 4	Gate
5 - 8	Drain
9	Paddle ¹

1. The exposed pad centered on the package bottom must be connected to RF and DC ground. This path must also provide a low thermal resistance heat path.

* Restrictions on Hazardous Substances, compliant to current RoHS EU directive.

Typical 2-Tone Performance: (measured in test fixture)

Freq. = 2500 MHz, $V_{DS} = 28$ V, $I_{DQ} = 200$ mA, Tone Spacing = 1 MHz, $T_C = 25^\circ\text{C}$

Parameter	Symbol	Min.	Typ.	Max.	Units
Peak Envelope Power 3 dB Compression 1 dB Compression	$P_{3dB, PEP}$ $P_{1dB, PEP}$	20 —	25 15	—	W
Small Signal Gain	G_{SS}	13	14	15	dB
Drain Efficiency @ 3 dB Compression	η	53	58	—	%

Typical OFDM Performance: (measured in load pull system (refer to Table 1 and Figure 1))

Frequency = 2500 - 2700 MHz, $V_{DS} = 28$ V, $I_{DQ} = 200$ mA, Single Carrier OFDM waveform 64-QAM 3/4, 8 burst, continuous frame data, 10 MHz channel bandwidth, Peak/Avg = 10.3 dB @ 0.01% probability on CCDF, $P_{OUT} = 1.5$ W avg., $T_C = 25^\circ\text{C}$

Parameter	Symbol	Typical	Units
Power Gain	GP	14.0	dB
Drain Efficiency	η	23.5	%
Error Vector Magnitude	EVM	2.0	%

Handling Procedures

Please observe the following precautions to avoid damage:

Static Sensitivity

Gallium Nitride Circuits are sensitive to electrostatic discharge (ESD) and can be damaged by static electricity. Proper ESD control techniques should be used when handling these HBM Class 1A devices.

DC Electrical Characteristics: $T_C = 25^\circ\text{C}$

Parameter	Test Conditions	Symbol	Min.	Typ.	Max.	Units
Off Characteristics						
Drain-Source Leakage Current	$V_{GS} = -8\text{ V}, I_D = 8\text{ mA}$	V_{BDS}	100	—	—	V
Gate-Source Leakage Current	$V_{GS} = -8\text{ V}, V_{DS} = 60\text{ V}$	I_{DLK}	—	—	4	mA
On Characteristics						
Gate Threshold Voltage	$V_{DS} = 28\text{ V}, I_D = 8\text{ mA}$	V_T	-2.3	-1.8	-1.3	V
Gate Quiescent Voltage	$V_{DS} = 28\text{ V}, I_D = 200\text{ mA}$	V_{GSQ}	-2.0	-1.5	-1.0	V
Maximum Drain Current	$V_{DS} = 7\text{ V}$ pulsed, pulse width 300 ms 0.2% Duty Cycle	$I_{D,MAX}$	—	5.0	—	A

Absolute Maximum Ratings^{2,3,4}

Parameter	Absolute Maximum
Drain Source Voltage, V_{DS}	100 V
Gate Source Voltage, V_{GS}	-10 to 3 V
Total Device Power Dissipation (derated above 25°C)	28 W
Junction Temperature, T_J	+200°C
Operating Temperature	-40°C to +85°C
Storage Temperature	-65°C to +150°C

2. Exceeding any one or combination of these limits may cause permanent damage to this device.
3. MACOM does not recommend sustained operation near these survivability limits.
4. Operating at nominal conditions with $T_J \leq 200^\circ\text{C}$ will ensure $MTTF > 1 \times 10^6$ hours.

Thermal Characteristics⁵

Parameter	Test Conditions	Symbol	Typical	Units
Thermal Resistance	$V_{DS} = 28\text{ V}, T_J = 200^\circ\text{C}$	$R_{\theta JC}$	6.25	°C/W

5. Junction temperature (T_J) measured using IR Microscopy. Case temperature measured using thermocouple embedded in heat-sink.

Table 1: Optimum Impedance Characteristics for Linear OFDM Tuning, single carrier OFDM waveform 64-QAM 3/4, 8 burst, continuous frame data, 10 MHz channel bandwidth. Peak/Avg = 10.3 dB @ 0.01% probability on CCDF

Frequency (MHz)	Z _S (Ω)	Z _L (Ω)	P _{OUT} (W)	Gain (dB)	Drain Efficiency (%)
2500	5.2 - j 1.6	3.3 + j 1.7	1.5	14.5	25
2600	4.6 - j 1.9	3.1 + j 2.7	1.5	14.5	25
2700	4.0 - j 2.2	2.9 + j 4.3	1.5	14.4	24

Table 2: Optimum Impedance Characteristics for CW P_{SAT}, Efficiency, and Gain

Frequency (MHz)	Z _S (Ω)	Z _L (Ω)	P _{SAT} (W)	G _{SS} (dB)	Drain Efficiency (%)
2500	3.7 - j 4.7	6.9 + j 1.2	23	14.5	60

Impedance Reference

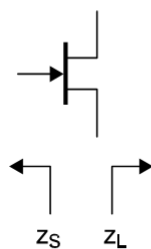

Z_S is the source impedance presented to the device.
Z_L is the load impedance presented to the device.

Z_S and Z_L vs. Frequency

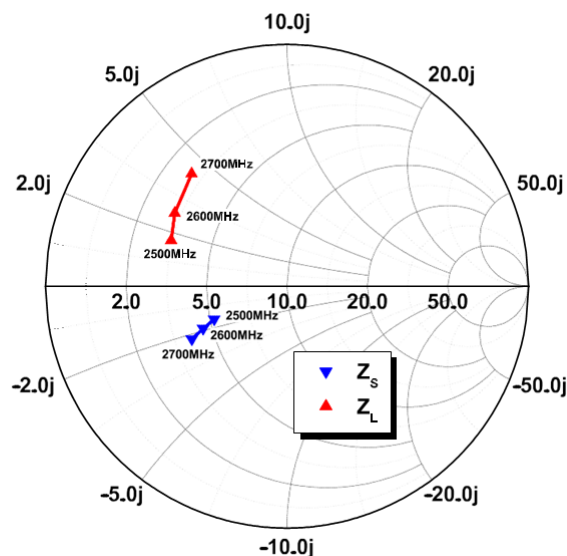

Figure 1 - Optimum Impedance Characteristics for OFDM Tuning, V_{DS} = 28 V, I_{DQ} = 200 mA

Load-Pull Data, Reference Plane at Device Leads:
Freq. = 2500 MHz, $V_{DS} = 28$ V, $I_{DQ} = 200$ mA (unless noted)

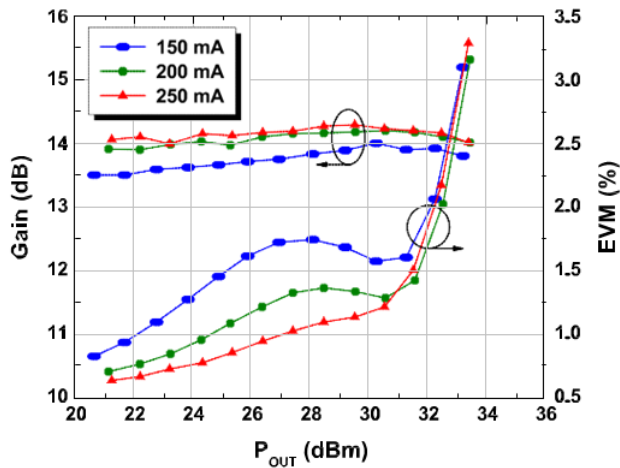

Figure 2 - Typical OFDM Performance

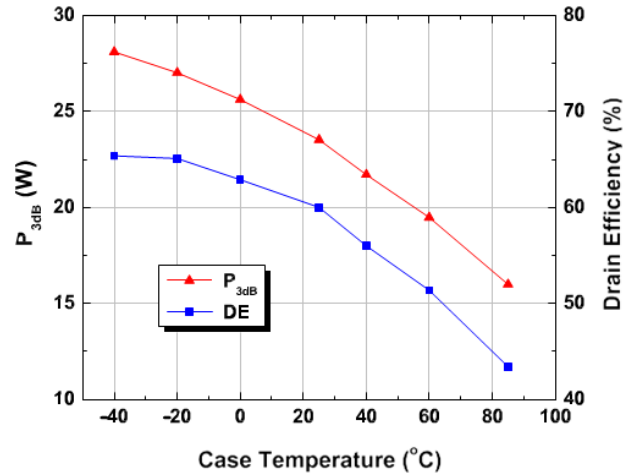

Figure 3 - P3dB, PEP and Drain vs. Temperature

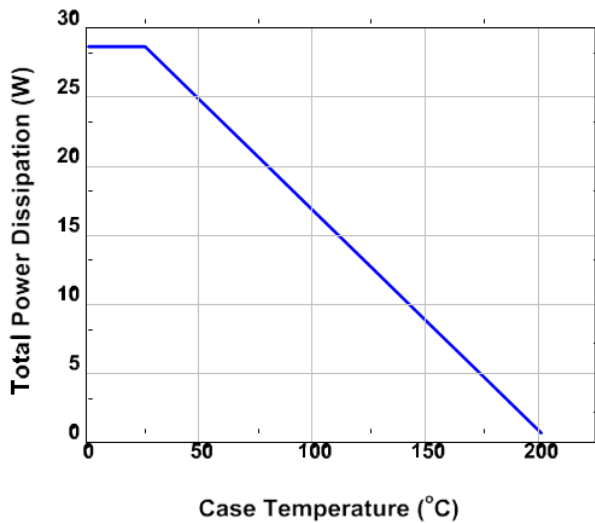

Figure 4 - Power Derating Curve

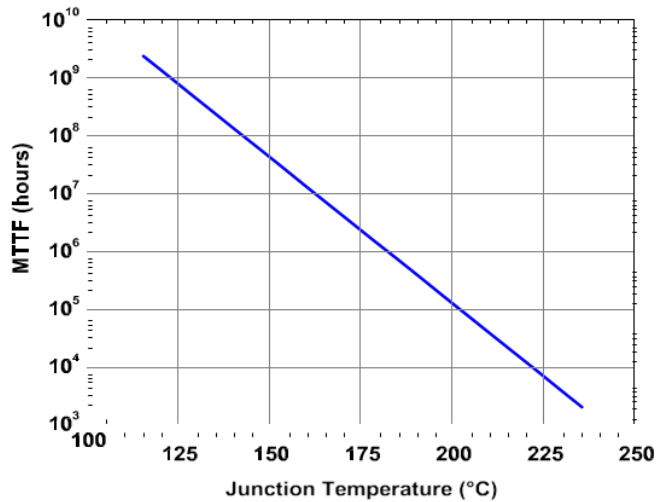
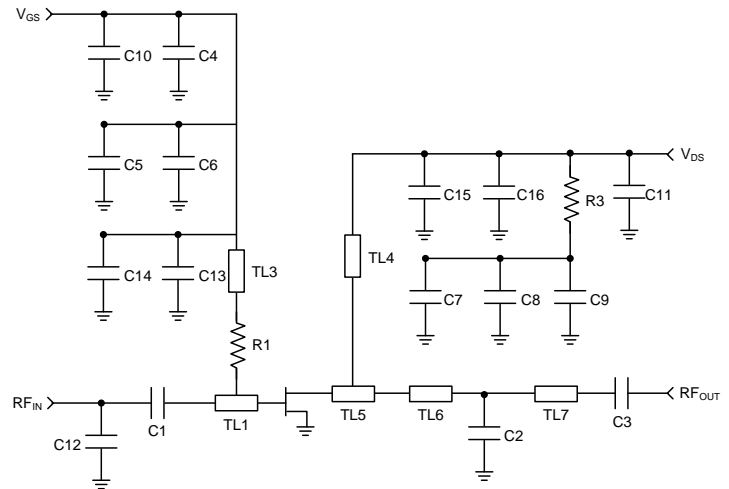
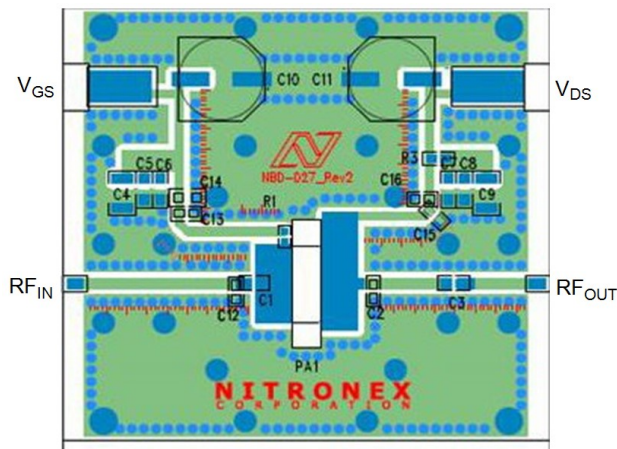

Figure 5 - MTTF of NRF1 devices as a function of temperature

APP-NPT25015-25, 2500 - 2700 MHz Linear WiMAX Application Board:
802.16e Single Carrier OFDM, 64-QAM 3/4, 8-burst, 20 ms frame 75% filled,
10 MHz channel bandwidth, PAR = 10.3 dB @ 0.01% CCDF



Parts list

Reference	Value	Tolerance	Manufacturer	Part Number
C1	5.6 pF	±0.1 pF	ATC	ATC600F5R6B
C2	2.2 pF	±0.1 pF	ATC	ATC600F2R2B
C3	3.3 pF	±0.1 pF	ATC	ATC600F3R3B
C4, C9	1 µF	10 %	Panasonic	ECJ-5YB2A105M
C5, C8	0.1 µF	10 %	Kemet	C1206C104K1RACTU
C6, C7	0.01 µF	10 %	AVX	12061C103KAT2A
C10	150 µF	20 %	Nichicon	UPW1C151MED
C11	270 µF	20 %	United Chemi-Con	ELXY630ELL271MK25S
C12	1 pF	±0.1 pF	ATC	ATC600F1R0B
C13, C15	33 pF	5 %	ATC	ATC600F330B
C14, C16	1000 pF	10 %	Kemet	C0805C102K1RACTU
R1	49.9 Ω	1 %	Panasonic	ERJ-2RKF49R9X
R3	0.33 Ω	1 %	Panasonic	ERJ-6RQFR33V
PCB	Rogers RO4350, ε _r =3.5, t = 30 mils			

Typical Performance Curves

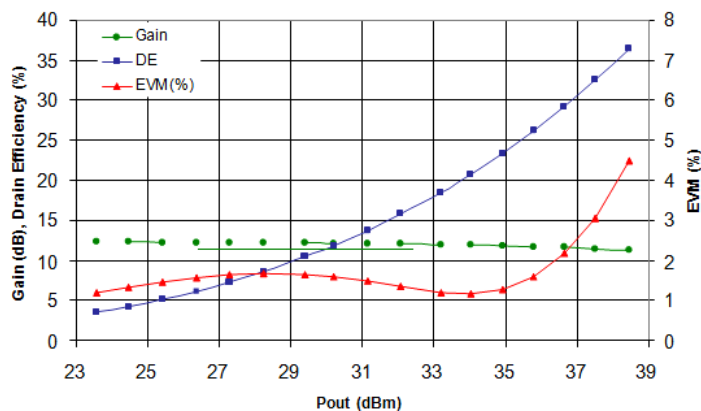

Figure 7 - Gain, Efficiency, EVM @ 2500 MHz

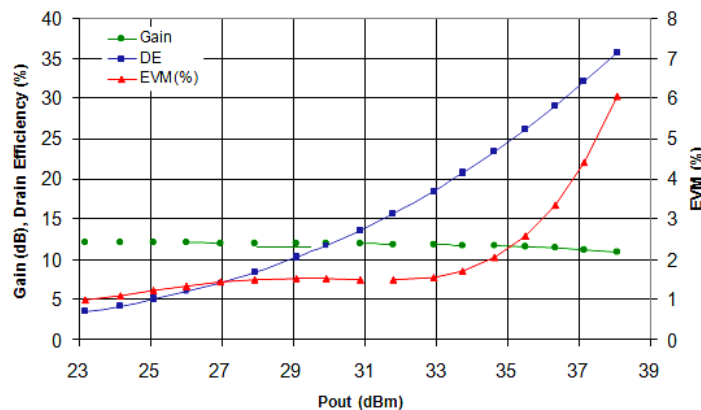

Figure 8 - Gain, Efficiency, EVM @ 2600 MHz

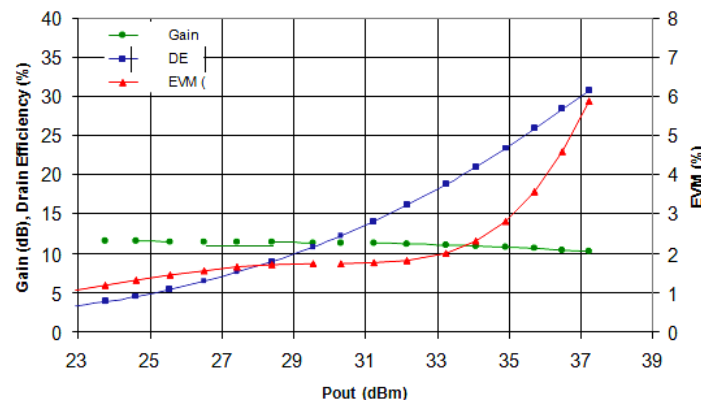
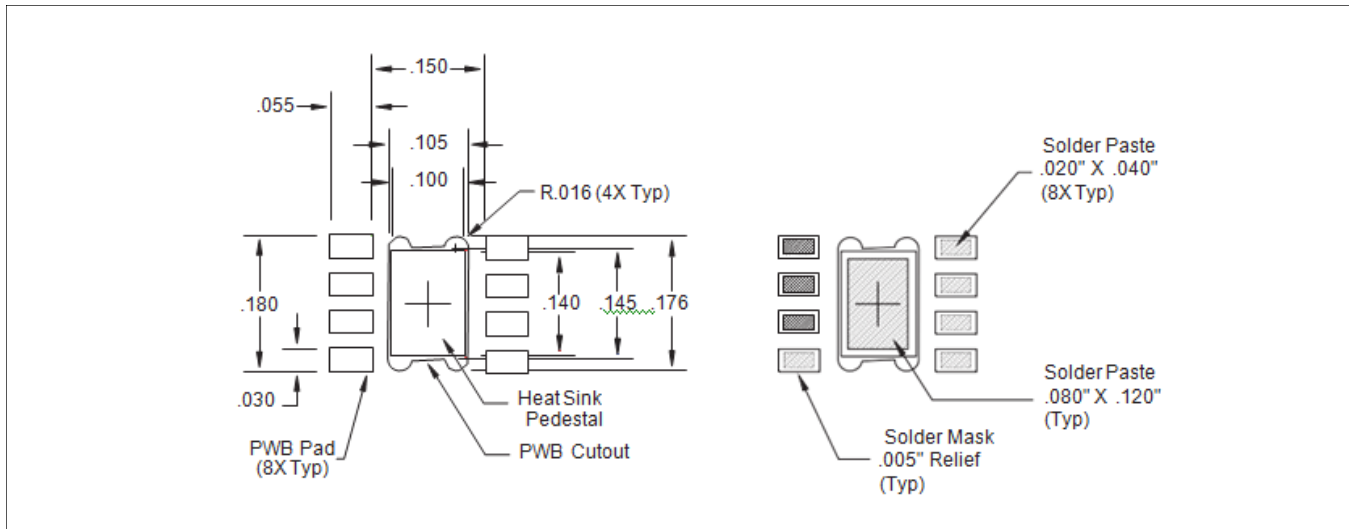
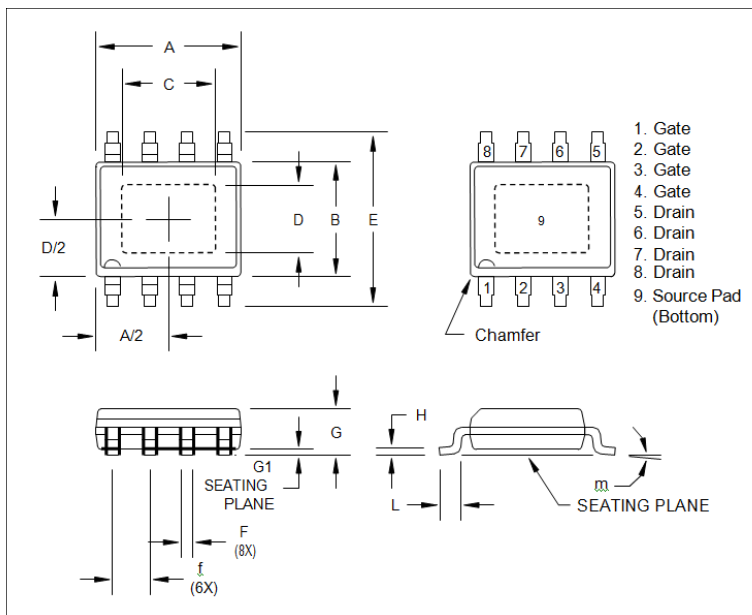

Figure 9 - Gain, Efficiency, EVM @ 2700 MHz

Mounting Footprint



Package Dimensions and Pin out[†]



Dim.	Inches		Millimeters	
	Min.	Max.	Min.	Max.
A	0.189	0.196	4.80	4.98
B	0.150	0.157	3.81	3.99
C	0.107	0.123	2.72	3.12
D	0.071	0.870	1.870	2.21
E	0.230	0.244	5.85	6.19
f	0.050 BSC		1.270 BSC	
F	0.0138	0.0192	0.35	0.49
G	0.055	0.061	1.40	1.55
G1	0.000	0.004	0.00	0.10
H	0.075	0.098	1.91	2.50
L	0.016	0.035	0.41	0.89
m	0°	8°	0°	8°

[†] Meets JEDEC moisture sensitivity level 3 requirements.
Plating is Matte Sn.

MACOM Technology Solutions Inc. ("MACOM"). All rights reserved.

These materials are provided in connection with MACOM's products as a service to its customers and may be used for informational purposes only. Except as provided in its Terms and Conditions of Sale or any separate agreement, MACOM assumes no liability or responsibility whatsoever, including for (i) errors or omissions in these materials; (ii) failure to update these materials; or (iii) conflicts or incompatibilities arising from future changes to specifications and product descriptions, which MACOM may make at any time, without notice. These materials grant no license, express or implied, to any intellectual property rights.

THESE MATERIALS ARE PROVIDED "AS IS" WITH NO WARRANTY OR LIABILITY, EXPRESS OR IMPLIED, RELATING TO SALE AND/OR USE OF MACOM PRODUCTS INCLUDING FITNESS FOR A PARTICULAR PURPOSE, MERCHANTABILITY, INFRINGEMENT OF INTELLECTUAL PROPERTY RIGHT, ACCURACY OR COMPLETENESS, OR SPECIAL, INDIRECT, INCIDENTAL, OR CONSEQUENTIAL DAMAGES WHICH MAY RESULT FROM USE OF THESE MATERIALS.

MACOM products are not intended for use in medical, lifesaving or life sustaining applications. MACOM customers using or selling MACOM products for use in such applications do so at their own risk and agree to fully indemnify MACOM for any damages resulting from such improper use or sale.