



- ⊙ Height: 3.35mm MAX
- ⊙ Footprint: 10.4mm x 10.4mm MAX
- ⊙ Current Rating: up to 7.0A
- ⊙ Inductance Range: 0.67μH to 325μH
- ⊙ Operating Temperature: -55°C to +130°C
- ⊙ Lead Finish: Sn63/Pb37
- ⊙ Moisture Sensitivity Level: 1

Electrical Specifications @ 25°C

Part Number	Inductance @ I _{rated} TYP (μH)	I _{rated} ⁴ (A)	DCR (mΩ)		Inductance @ 0 ADC (μH)	Saturation Current ⁵ @ 25°C (A)	Heating Current ⁶ (A)
			TYP	MAX			
PL9401 ³	0.67	7.0	3.4	4.4	0.68	7.0	13
PL9402 ³	1.3	6.1	4.9	6.4	1.5	6.1	9.3
PL9403 ³	2.1	5.7	8.0	10.4	2.2	5.7	7.4
PL9404 ³	3.1	4.8	12	15.6	3.3	4.8	5.9
PL9405 ³	4.5	4.1	16.3	21.2	4.7	4.1	5.0
PL9406 ³	5.8	3.6	19.4	25.2	6.2	3.6	4.5
PL9407 ³	7.0	3.3	21.4	27.8	6.8	3.3	4.15
PL9408	9.4	3.0	30.4	39.5	8.2	3.0	3.5
PL9409	11	2.7	33	42.9	10	2.7	3.25
PL9410	12	2.4	37	50	12	2.4	2.85
PL9411	15	2.25	48.3	65.2	15	2.25	2.65
PL9412	24	1.85	63.8	86.1	22	1.85	2.25
PL9413	35	1.4	93	126	33	1.40	1.85
PL9414	48	1.25	139	188	47	1.25	1.45
PL9415	55	1.15	154	208	56	1.15	1.35
PL9416	64	1.05	207	279	68	1.05	1.20
PL9417	88	0.94	235	317	82	0.94	1.08
PL9418	106	0.88	265	358	100	0.88	1.0
PL9419	129	0.80	354	478	120	0.80	0.93
PL9420	157	0.70	404	545	150	0.70	0.83
PL9421	238	0.58	620	839	220	0.58	0.75
PL9422	325	0.45	888	1199	330	0.45	0.73

NOTES:

1. Add suffix "NL" for RoHS compliant version; i.e. PL9401 becomes **PL9401NL**. NL parts have 100% SN Lead Finish (MSL:4)
2. For Tape & Reel packaging, add "T" suffix at the end of the part number: i.e. **PL9401T**.
3. Inductance at OADC tolerance on indicated part numbers is ±30%; tolerance is ±20% on all other parts.
4. Temperature of the component (ambient plus temperature rise) must be within specified operating temperature range.
5. The rated current as listed is either the saturation current or the heating current depending on which value is lower.
6. The saturation current is the current which causes the inductance to drop to 75% of its initial inductance at zero bias. This current is determined by placing the component at room ambient (25°C), and applying a short duration pulse current (to eliminate self-heating effects) to the component.
7. The heating current is the DC current, which causes the temperature of the part to increase by approximately 40°C. This current is determined by extending the terminals of the component with 30mm length 28 gauge buss wires and applying the current to the device for 30 minutes. The temperature is measured by placing the thermo-couple between the winding and the shield.
8. In high volt*time applications, additional heating in the component can occur due to core losses in the inductor which may necessitate derating the current in order to limit the temperature rise of the component. In order to determine the approximate total loss (or temperature rise) for a given application, both copper losses and core losses should be taken into account.

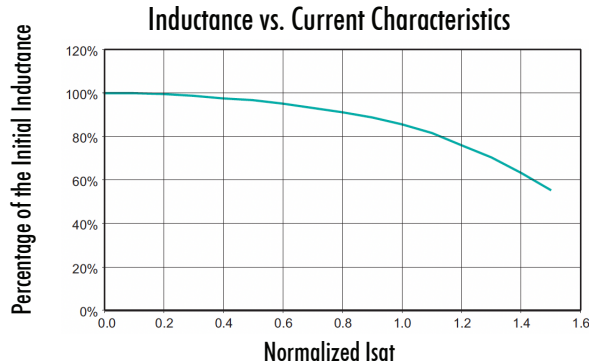

PL94XX

Mechanicals

Electrical Schematics

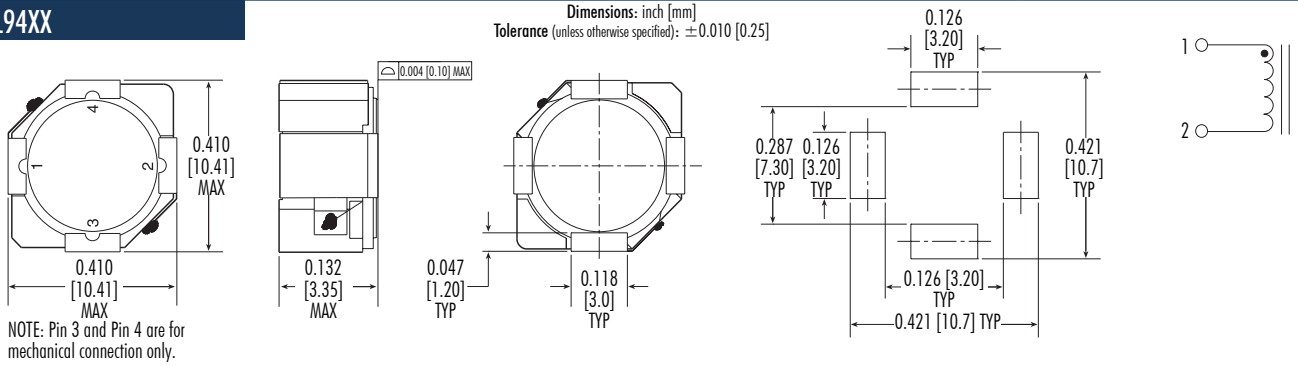

Recommended Reflow Profile (Based on J-STD-020D)

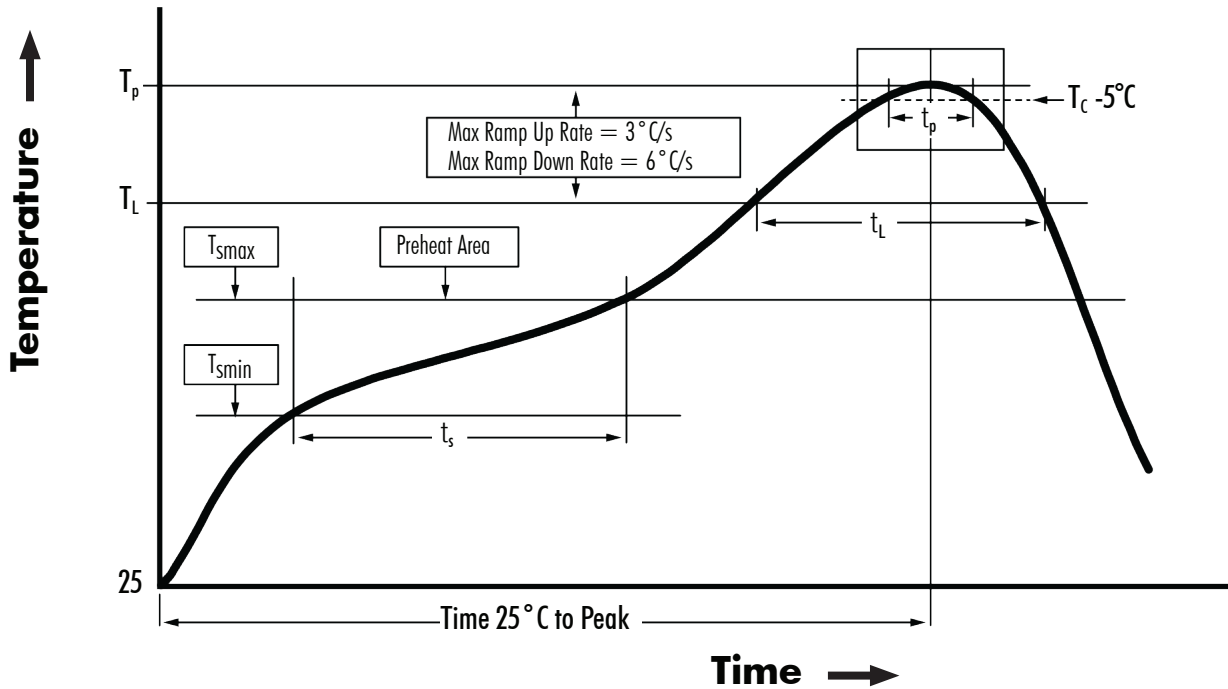

T_{SMIN} (°C)	T_{SMAX} (°C)	T_L (°C)	T_P (°C MAX)	t_s (s)	t_L (s)	t_p (s MAX)	Ramp-up rate (T_L to T_P)	Ramp-down rate (T_P to T_L)	Time 25°C to peak temperature (s MAX)
100	150	183	235	60 - 120	60 - 150	20	3°C/s MAX	6°C/s MAX	360

NOTES:

1. All temperatures measured on the package leads.
2. Maximum number of reflow cycles not to exceed 2.



iNRCORE, LLC
 311 Sinclair Road, Bristol, PA 19007-6812 USA
 Tel: +1.215.781.6400 Fax: +1.215.781.6430

www.iNRCORE.com

M123.E (1MAY24)

Performance warranty of products offered on this data sheet is limited to the parameters specified. Data is subject to change without notice. Other brand and product names mentioned herein may be trademarks or registered trademarks of their respective owners. © Copyright, 2024. iNRCORE, LLC. All rights reserved.