



QLSP27RD
PLCC 2
30 degree



Product Outline:

This high output reflector type 3528 LEDs are available in Red color. This special package is ideal for customer's application in traffic signal and sign boards. With special binning technology, Quelighting is able to provide special binning for customer's needs

Features:

- High brightness output @ 50mA
- Package Dimension = 3.5mmX2.8mmX3.5mm
- PLCC-2 30 degree viewing angle
- RoHS compliant
- Custom Bin available upon special request

Application:

- Sign board backlighting
- Emergency vehicle lighting
- Traffic signal lighting

Compliance and Certification:



**Mechanical Property:
(Dimension)**

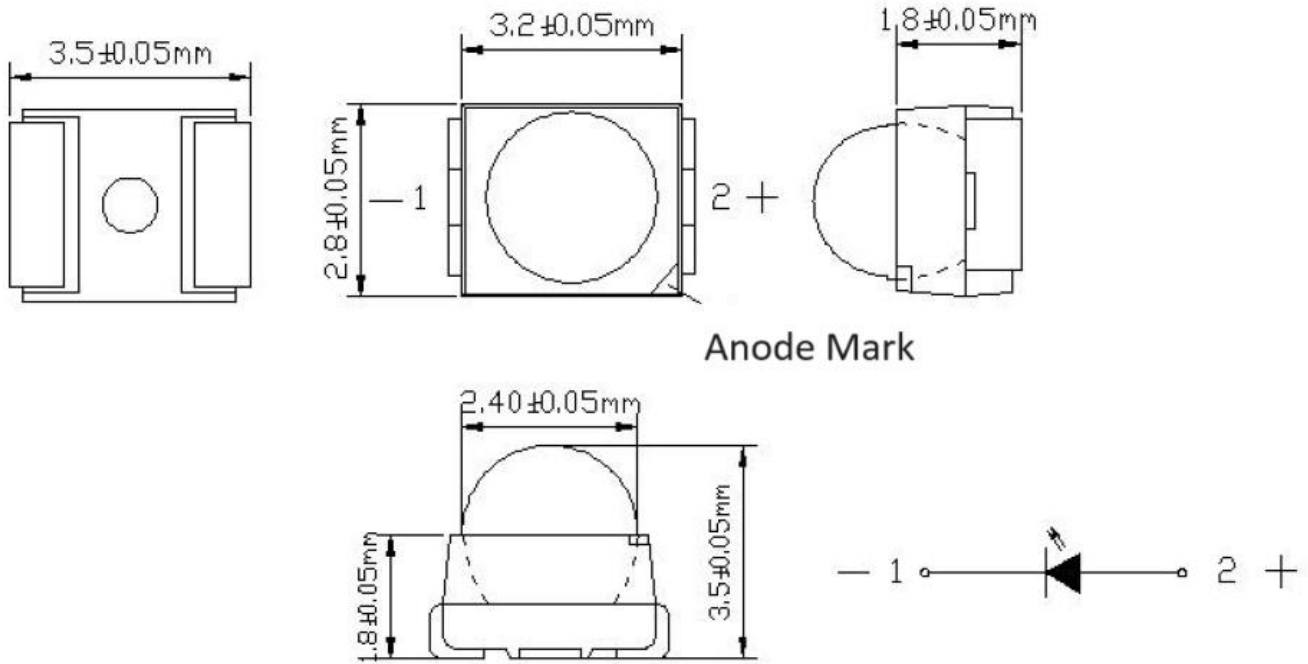

Units: mm

Back side layout for Solder footprint purpose:

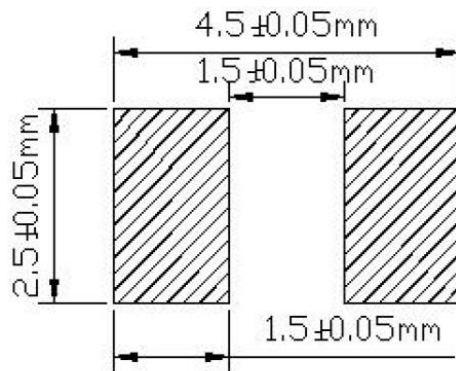

Units: mm



Electrical / Optical Characteristic

(T=25°C)

Product	Color	I _F (mA)	V _F (V)		λD (nm)			I _v (mcd)	
			Typ.	max	Min.	Typ.	Max.	min	typ.
QLSP27RD	Red	50	2.0	2.6	620	-	630	5000	6000

(1) The Forward Voltage tolerance is ±0.1V

(2) The λD tolerance is ±1nm

 (3) The I_v tolerance is ± 7%

Absolute Maximum Rating

(T=25°C)

Part #	P _d (mW)	I _F (mA)	I _{FP} (mA)*	V _R (V)	T _{OP} (°C)	T _{ST} (°C)	T _{SOL} (°C)**
QLSP27RD	100	50	80	5	-40 – 85	-40 - 100	260

*Duty 1/10 @ 10Khz

** Junction Temperature

*** IR Reflow for no more than 10 sec @ 260 °C

**** Thermal resistance is calculated from junction to solder



Forward Voltage (V_F) Bin:

VF rank @ 50mA			
Code name	Min.	Max.	Unit
RS	2.0	2.2	V
TU	2.2	2.4	
VW	2.4	2.6	

The forward voltage tolerance is $\pm 0.1V$

Luminous Intensity Bin:

Iv rank @ 50mA			
Code name	Min.	Max.	Unit
X57	5000	8000	mcd

luminous intensity tolerance is $\pm 7\%$

Dominant Wavelength Bin:

λ_D @ IF=50mA			
Code name	Min.	Max.	Unit
A8	620	625	nm
A9	625	630	



Characteristic Curves

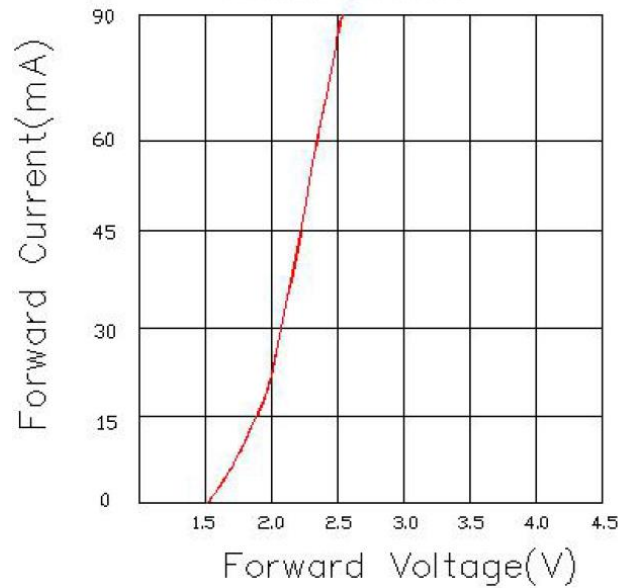

Forward Voltage vs. Forward Current

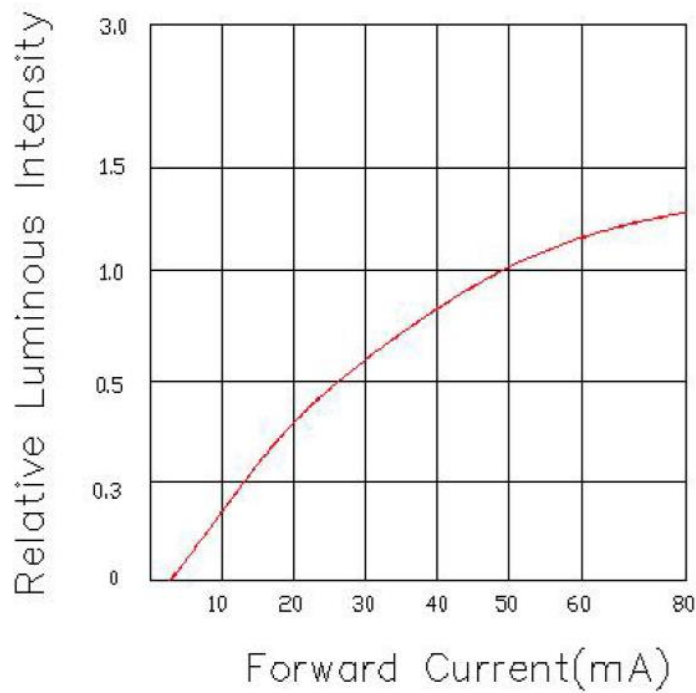

Forward current vs. Relative luminous intensity



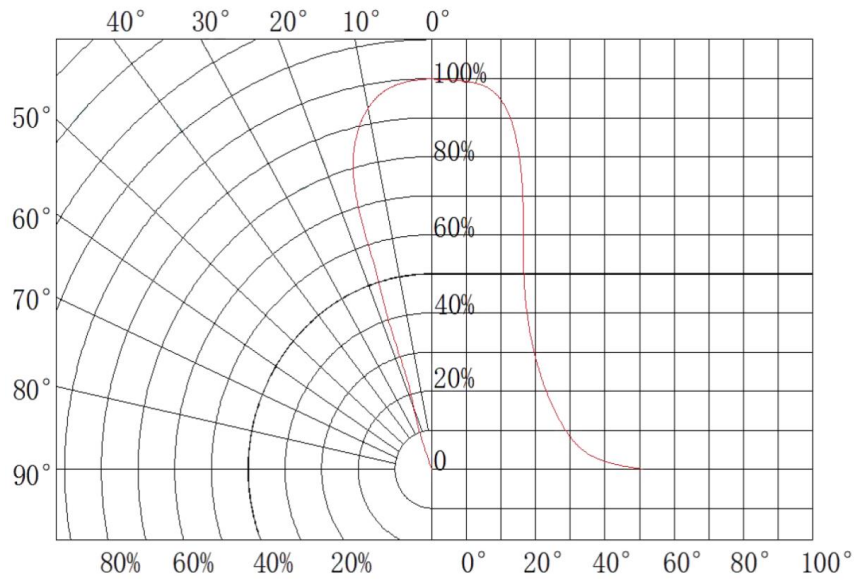

Radiation Pattern

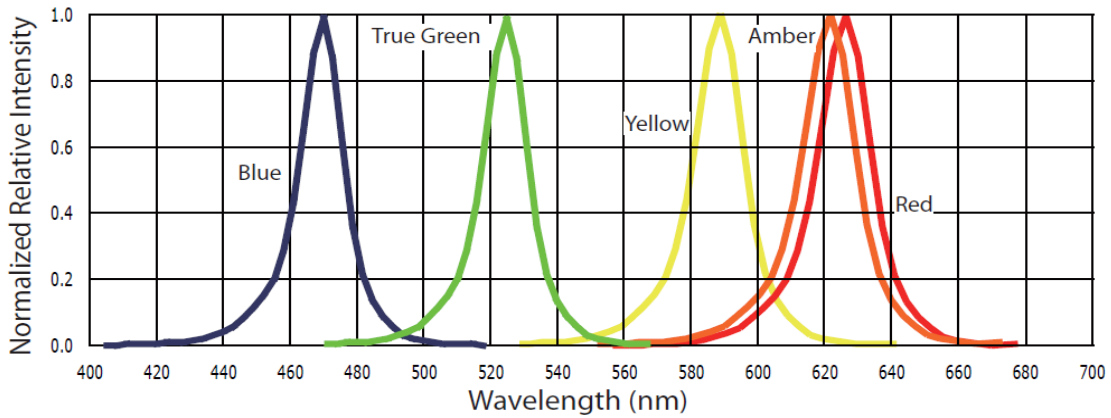

Spectrum Distribution



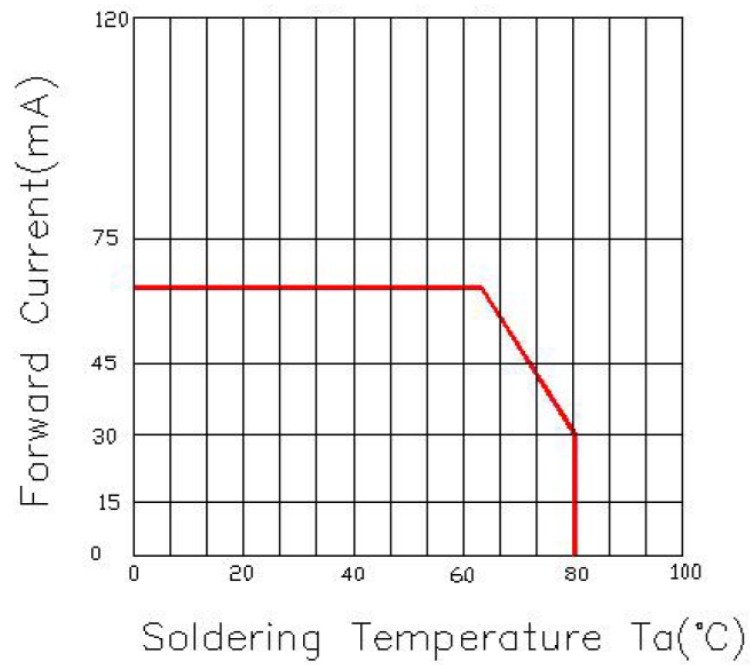

Relative Forward Voltage vs Ambient Temperature

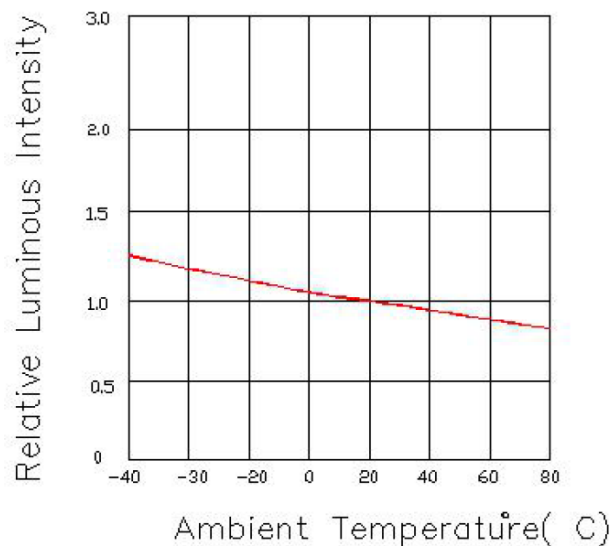

Relative Luminous Intensity vs Ambient Temperature



Solder Profile:

-The recommended reflow soldering profile is as follows (temperatures indicated are as measured on the surface of the LED resin):

- When soldering LEDs,
- Do not solder/reflow the same LED over two times.
- Recommend soldering conditions:
 - Hand soldering: 300 °C max , 3 sec. max.
 - Reflow soldering: Pre-heat 150 max , 180 sec. max. °C
 - Peak 260 ma °C x , 5 sec. max.
- Reflow temperature profile as below: (lead-free solder)

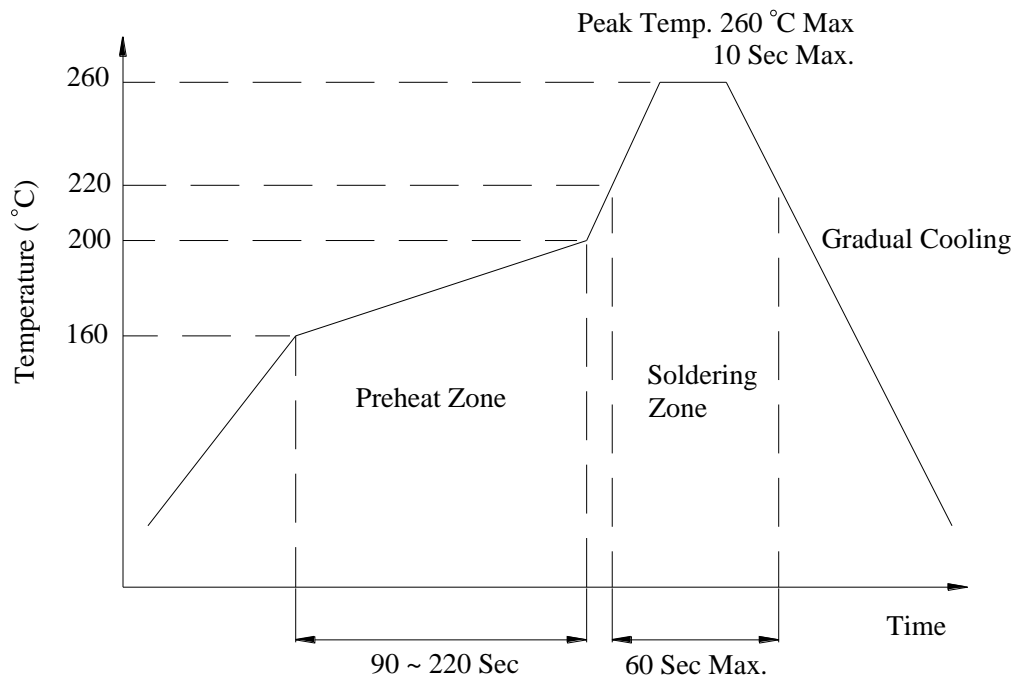

Taping & Packing:

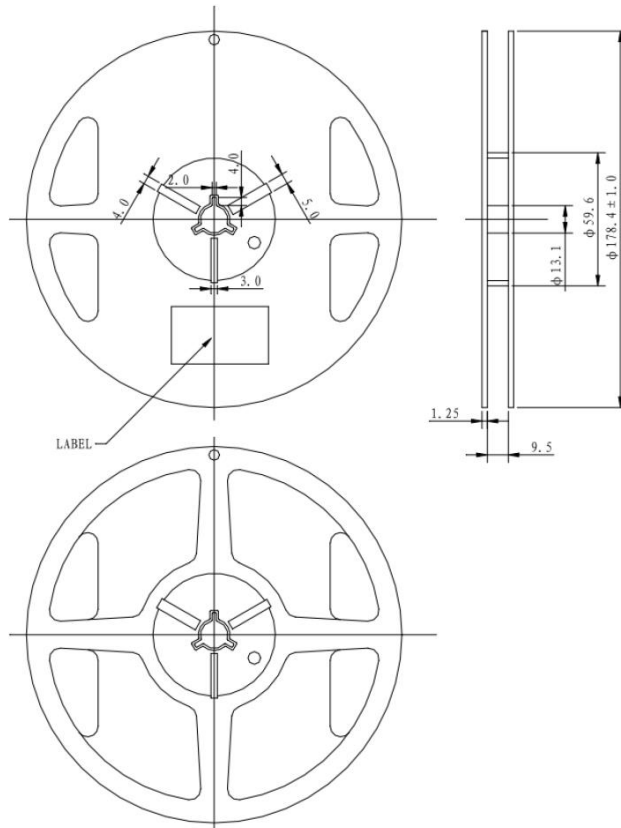
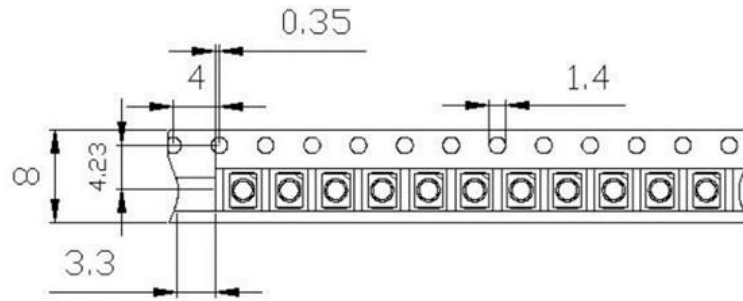

Unit : mm

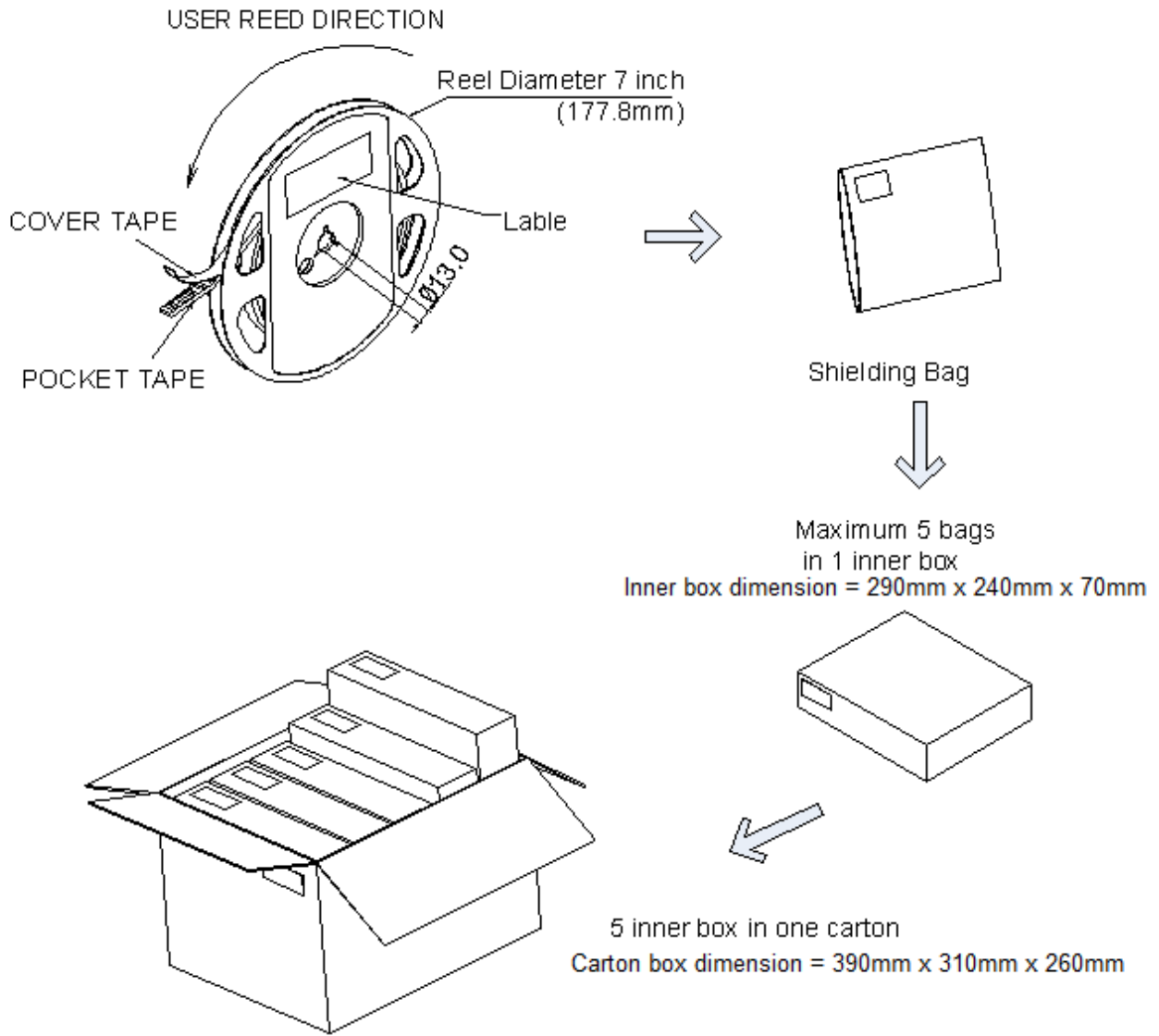

Labeling



Quantity: XXXX



Quelighting P/N: XXXXXX



Lot number: XXXXX



Iv Bin: XX Color Bin: XX Vf Bin: XX

Date Code: XXXX

Ordering Information:

Part #	Multiple Quantities	Quantity per Reel
QLSP27RD		2000 pcs



Revision History:

Revision Date:	Changes:	Version #:
11-01-2020	Initial release	1.0

