

RS31210 RS31310 Simple 5V/12V eFuse Protection Switches

Features

- 5V eFuse – RS31210
- 12V eFuse – RS31310
- Integrated 25mΩ Pass MOSFET
- Adjustable 2A to 5A current limit
- Adjustable input UVLO threshold
- Fixed over-voltage camp: 6.1V for RS31210 and 15V for RS31310
- Built-on over temperature protection
- Small 3x3mm VSON package
- RoHS compliant and Green

Applications

- Server and AUX supplies
- PCI and PCIe cards
- Adapter powered devices
- HDD and SSD drivers

Description

The RS31210 and RS31310 are active circuit protection devices with an integrated MOSFET used to limit current and voltage to safe levels during fault conditions.

The current limit level can be set with a resistor between ILIM and ground, and the typical current limit accuracy is $\pm 15\%$.

The device has over voltage protection feature which limits the output voltage to a fixed level when over voltage fault occurs.

To limit the inrush current during device turn-on, the rising slew rate of output voltage can be set by a capacitor between dV/dT and ground.

The device also offers EN on/off control and input UVLO features.

The device is available in VSON 10 pins, 3x3 mm package.

PART NUMBER	PACKAGE	BODY SIZE
RS31210	VSON-10	3x3 mm
RS31310		

Typical Application Circuit

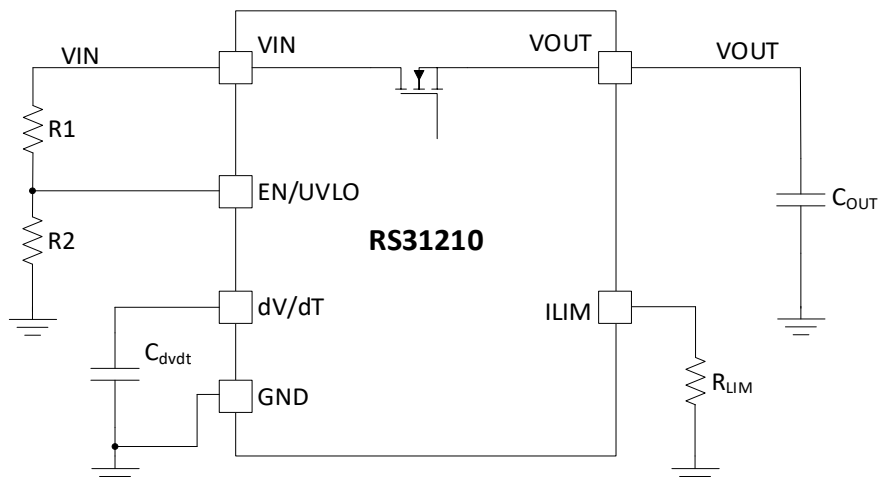

Package Reference

Top View

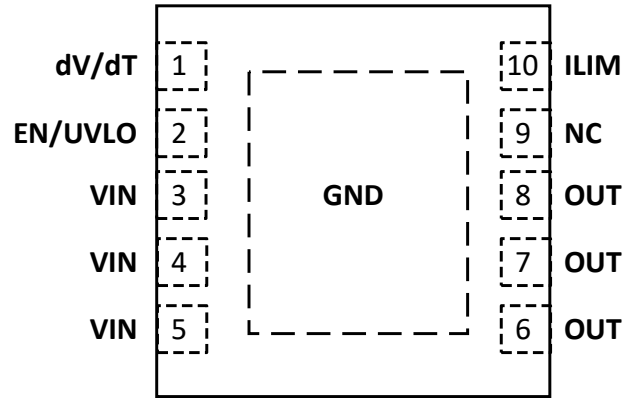

VSON-10 (3x3 mm)

Device Comparison Table

Part Number	Input UV	Output OV	Fault Response
RS31210A	4.3V	6.1V	Latch
RS31210B	4.3V	6.1V	Auto Retry
RS31310A	4.3V	15V	Latch
RS31310B	4.3V	15V	Auto Retry

Order Information

Part Number	Package	Size	MSL	Shipping Method	Package Marking
RS31210AT	VSON-10	3x3 mm	Level-2	250u Tape & Reel	R1210A
RS31210AR	VSON-10	3x3 mm	Level-2	5000u Tape & Reel	R1210A
RS31210BT	VSON-10	3x3 mm	Level-2	250u Tape & Reel	R1210B
RS31210BR	VSON-10	3x3 mm	Level-2	5000u Tape & Reel	R1210B
RS31310AT	VSON-10	3x3 mm	Level-2	250u Tape & Reel	R1310A
RS31310AR	VSON-10	3x3 mm	Level-2	5000u Tape & Reel	R1310A
RS31310BT	VSON-10	3x3 mm	Level-2	250u Tape & Reel	R1310B
RS31310BR	VSON-10	3x3 mm	Level-2	5000u Tape & Reel	R1310B

Top Marking

RSYYWW
PPPPPP
LLLLLS
●

Line 1

- RS: Prefix of Reed Semiconductor (RS is replaced by RE for engineering lot)
- YY: Year code
- WW: Week code

Line 2

- PPPPPP: Truncated part number. Example: R1210A represents the full part number RS31210A

Line 3

- LLLLLL: Lot code
- S: Assembly site code

Pin Description

No.	NAME	TYPE	Description
1	dV/dT	O	Connect a capacitor from this pin to GND to set output voltage rising slew rate during turn-on
2	EN/UVLO	I	Pull high to enable the device, and pull low to disable the device. Connect the pin to a resistor divider from Vin to GND to set input UVLO threshold
3, 4, 5	VIN	I	Input supply voltage
6,7,8	OUT	O	Output of the device
9	NC	NC	No internal connection. This pin can be floating or grounded.
10	ILIM	O	A resistor from this pin to GND sets the over current limit
11	GND	G	The GND pad is used as the device ground as well as thermal pad to dissipate heat.

PACKAGE DIMENSION (RS31210)

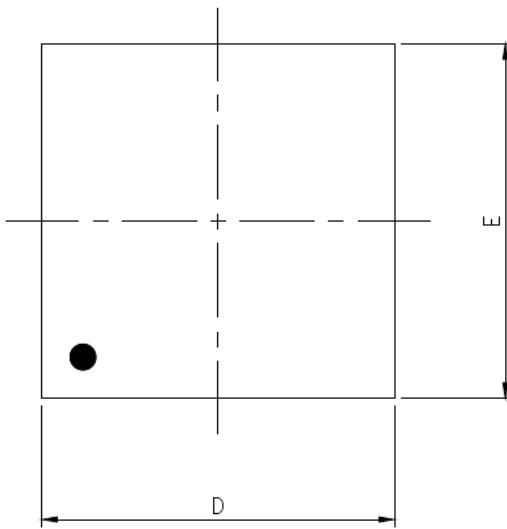

TOP VIEW

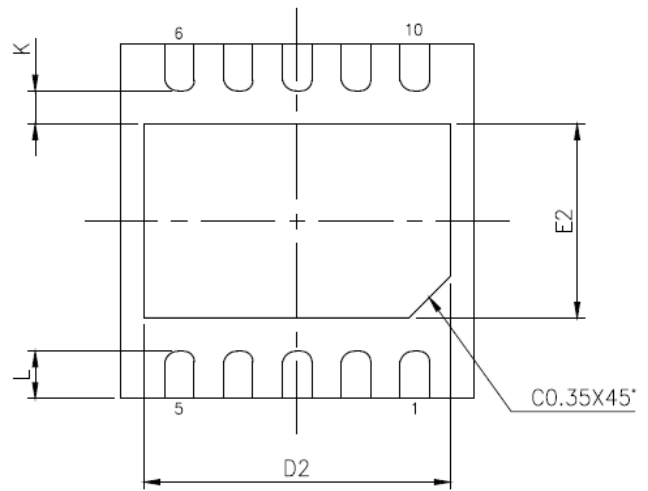

BOTTOM VIEW

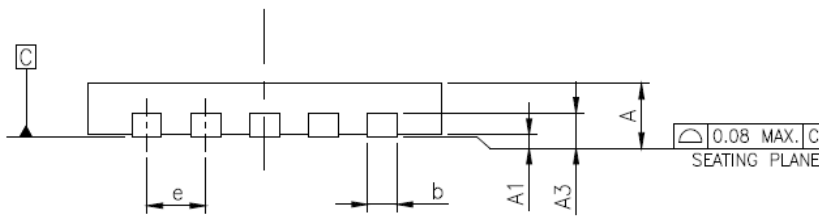

SIDE VIEW

SYMBOLS	MIN	NOM	MAX
A	0.80	0.85	0.90
A1	0.00	0.02	0.05
A3	0.203 REF		
b	0.18	0.25	0.30
D	3.00 BSC		
E	3.00 BSC		
e	0.50 BSC		
K	0.20		
D2	2.20	2.30	2.35
E2	1.55	1.65	1.70
L	0.30	0.40	0.50

NOTE:

1. ALL DIMENSIONS ARE IN MILLIMETERS.
2. DIMENSION b APPLIES TO METALLIZED TERMINAL AND IS MEASURED BETWEEN 0.15mm AND 0.30mm FROM THE TERMINAL TIP. IF THE TERMINAL HAS THE OPTIONAL RADIUS ON THE OTHER END OF THE TERMINAL, THE DIMENSION b SHOULD NOT BE MEASURED IN THAT RADIUS AREA.
3. BILATERAL COPLANARITY ZONE APPLIES TO THE EXPOSED HEAT SINK SLUG AS WELL AS THE TERMINALS.

PACKAGE DIMENSION (RS31310)

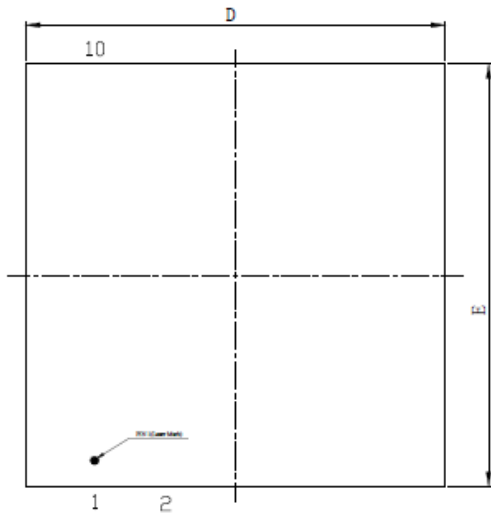

TOP VIEW

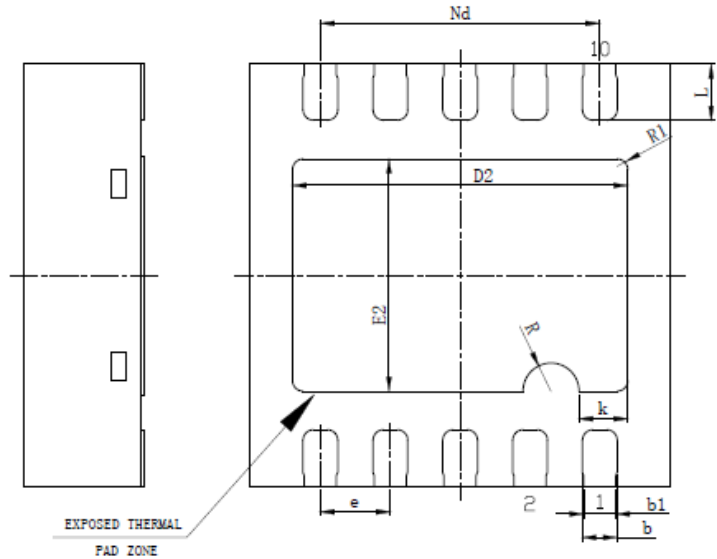

BOTTOM VIEW

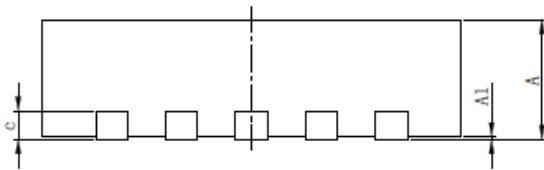

SIDE VIEW

SYMBOLS	MIN	NOM	MAX
A	0.80	0.85	0.90
A1	0.00	0.02	0.05
b	0.20	0.25	0.30
b1	0.23 REF		
c	0.203 REF		
D	2.90	3.00	3.10
D2	2.35	2.40	2.45
e	0.50 BSC		
Nd	2.00 BSC		
E	2.90	3.00	3.10
E2	1.60	1.65	1.70
L	0.35	0.40	0.45
R	0.20 REF		
R1	0.075 REF		
k	0.35 REF		

NOTE:

1. ALL DIMENSIONS ARE IN MILLIMETERS.
2. DIMENSION b APPLIES TO METALLIZED TERMINAL AND IS MEASURED BETWEEN 0.15mm AND 0.30mm FROM THE TERMINAL TIP. IF THE TERMINAL HAS THE OPTIONAL RADIUS ON THE OTHER END OF THE TERMINAL, THE DEMENSION b SHOULD NOT BE MEASURED IN THAT RADIUS AREA.
3. BILATERAL COPLANARITY ZONE APPLIES TO THE EXPOSED HEAT SINK SLUG AS WELL AS THE TERMINALS.

RECOMMENDED LAND PATTERN

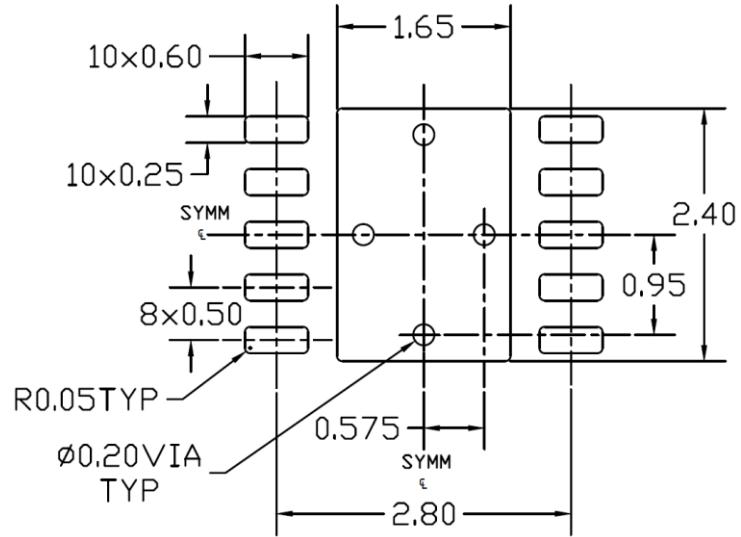

Note: All dimensions are in millimeters.

TAPE AND REEL INFORMATION

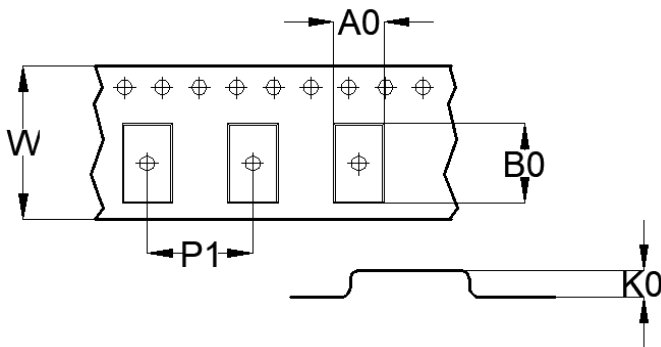
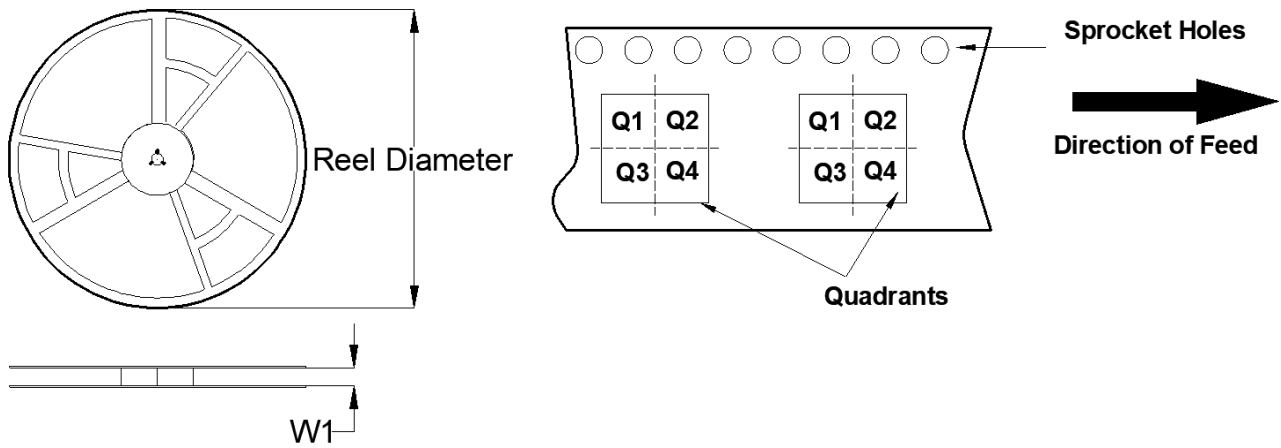

A0	Pocket width
B0	Pocket length
K0	Pocket thickness
W1	Reel Width
W	Inner width of the carrier tape
P1	Pitch between pocket centers

PKG type (mm)	Reel Diameter (mm)	Reel Width W1(mm)	A0(mm)	B0(mm)	K0(mm)	P1(mm)	W(mm)	Quad
3x3	330	12.8	3.3	3.3	1.10	8.00	12.0	Q2

Note: All the data is nominal

PIZZA BOX DIMENSION

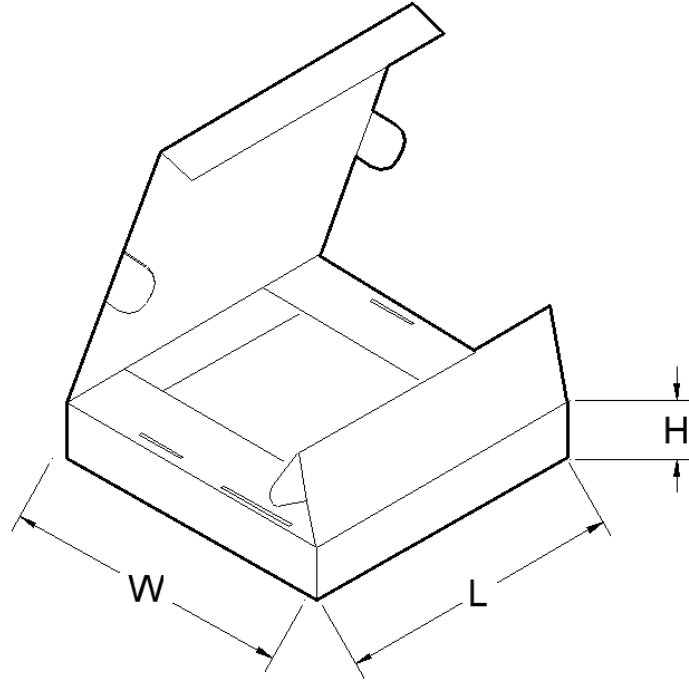

PKG type (mm)	Units/box	Length(mm)	Width(mm)	Height(mm)
3x3	5000	355	340	50

Note: All the data is nominal