

RS31313 RS31314 RS31317 4.5V to 16V, 15A eFuse with Hot Swap Protection and Current Monitoring

Features

- Wide input voltage range: 4.5V to 16V
- Integrated 2.7mΩ Pass MOSFET
- Adjustable 2A to 15A current limit
- Adjustable over-current blanking timer for load transient without tripping
- Accurate current monitor
- Configurable fault response
 - Latch-off or auto-retry
 - Number of retries
 - Delay between retries
- Fast trip short-circuit protection: <400ns typical
- Adjustable output slew rate
- Adjustable input under-voltage lockout
- Input over-voltage protection (fixed 7.6V, 16.5V or no OVP options)
- Adjustable load detect and handshake timer
- Integrated overtemperature protection
- RoHS compliant and Green

Description

The RS31313 family of eFuses is an active circuit protection device with integrated MOSFET used to limit current and voltage to safe levels during fault conditions.

The current limit level can be set with a resistor between ILIM and ground, and the typical current limit accuracy is $\pm 1.5\%$ at 25°C.

The device has input over voltage protection feature to protect output load in the event of input over voltage fault.

To limit the inrush current during device turn-on, the rising slew rate of output voltage can be set by a capacitor between dV/dt and ground.

In addition, the device has adjustable over-current blanking timer to avoid over-current tripping during output load transient.

The device also offers EN on/off control and input UVLO features.

The device is available in LGA-26, 4x4 mm package.

Applications

- Server and AUX supplies
- PCI and PCIe cards
- Router and switch optical module
- Digital TV

Typical Application Circuit

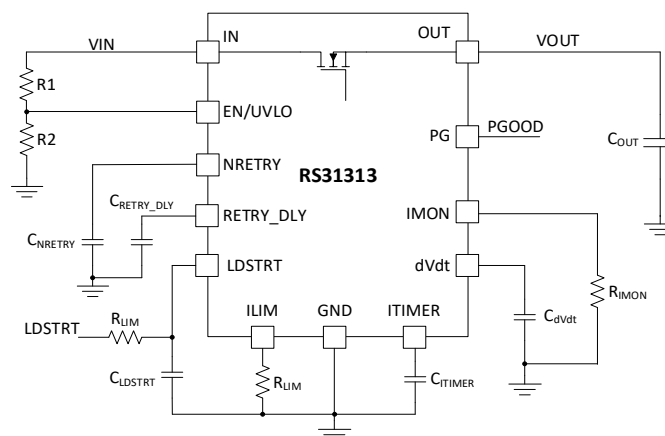

Package Reference

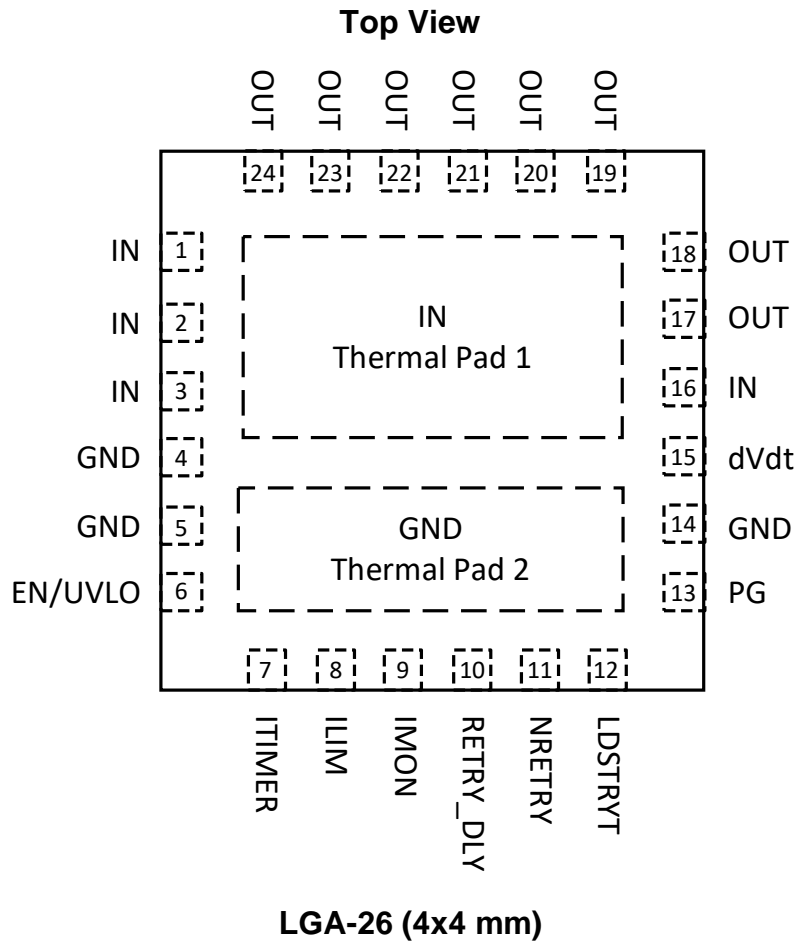

Device Comparison Table

Part Number	Over Voltage Threshold	Over Current Response
RS31313A	7.6V	Active Current Limiter
RS31314A	16.5V	Active Current Limiter
RS31317A	No OV	Active Current Limiter
RS31313B	7.6V	Circuit Breaker
RS31314B	16.5V	Circuit Breaker
RS31317B	No OV	Circuit Breaker

Part Number and Order Information

Part Number	Package	Size	MSL	Shipping Method	Package Marking
RS31313AT	LGA-26	4x4 mm	Level-3	250u Tape & Reel	R1313A
RS31313AR	LGA-26	4x4 mm	Level-3	5000u Tape & Reel	R1313A
RS31313BT	LGA-26	4x4 mm	Level-3	250u Tape & Reel	R1313B
RS31313BR	LGA-26	4x4 mm	Level-3	5000u Tape & Reel	R1313B
RS31314AT	LGA-26	4x4 mm	Level-3	250u Tape & Reel	R1314A
RS31314AR	LGA-26	4x4 mm	Level-3	5000u Tape & Reel	R1314A
RS31314BT	LGA-26	4x4 mm	Level-3	250u Tape & Reel	R1314B
RS31314BR	LGA-26	4x4 mm	Level-3	5000u Tape & Reel	R1314B
RS31317AT	LGA-26	4x4 mm	Level-3	250u Tape & Reel	R1317A
RS31317AR	LGA-26	4x4 mm	Level-3	5000u Tape & Reel	R1317A
RS31317BT	LGA-26	4x4 mm	Level-3	250u Tape & Reel	R1317B
RS31317BR	LGA-26	4x4 mm	Level-3	5000u Tape & Reel	R1317B

Top Marking

RSYYWW
PPPPPP
LLLLLS
●

Line 1

- RS: Prefix of Reed Semiconductor (RS is replaced by RE for engineering lot)
- YY: Year code
- WW: Week code

Line 2

- PPPPPP: Truncated part number

Line 3

- LLLLL: Lot code
- S: Assembly site code

Pin Description

No.	NAME	TYPE	Description
1, 2, 3, 16, Pad 1	IN	I	Power input. Solder the IN pins and thermal pad1 to input power plane on mother board with multiple vias for heat dissipation.
17-24	OUT	O	Power Output. Connect OUT pins to load circuit with wide copper plane.
4,5,14, Pad2	GND	G	Device ground. Solder the GND pins and thermal pad2 to system ground on mother board with multiple vias for heat dissipation.
6	EN/UVLO	I	Pull high to enable the device, and pull low to disable the device. Connect the pin to a resistor divider from Vin to GND to set input UVLO threshold. Do not leave the pin floating.
7	ITIMER	I	A capacitor from this pin to GND sets the over current blanking time during which the output current can temporarily exceed the current limit threshold. Leave the pin open for fastest over current response.
8	ILIM	O	An external resistor from the pin to GND sets the over current threshold and fast trip threshold. Do not leave the pin floating.
9	IMON	O	Output current monitor. The pin source a current proportional to the load current. An external resistor from the pin to GND converts the current to voltage signal.
10	RETRY_DLY	O	A capacitor from the pin to GND set the hiccup time from fault shutdown to restart. Connect the pin to GND for latch-off operation fault a fault.
11	NRETRY	O	A capacitor from the pin to GND sets the number of times the part attempts to restart after fault shutdown. Connect the pin to GND make the part retry infinitely.
12	LDSTRT	I	Load detect and handshake signal. A capacitor from the pin to GND set the time period after PG assertion within which the pin has to be pulled low for the device to remain ON. Connect the pin to GND if load detect and handshake feature is not used. Do not leave the pin floating.
13	PG	O	Open drain pin. Power Good indication.
15	dV/Dt	O	Connect a capacitor from this pin to GND to set output voltage rising slew rate during turn-on

PACKAGE DIMENSION

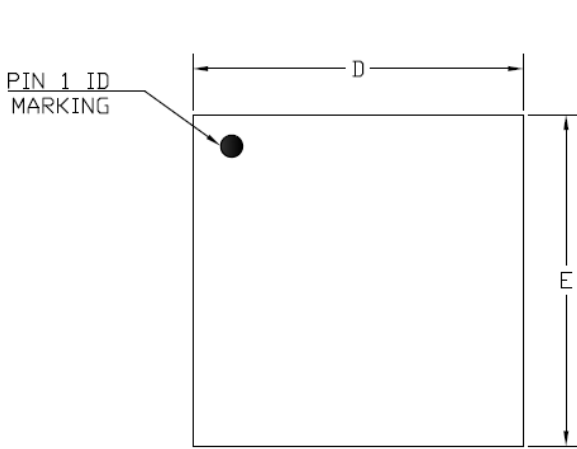

TOP VIEW

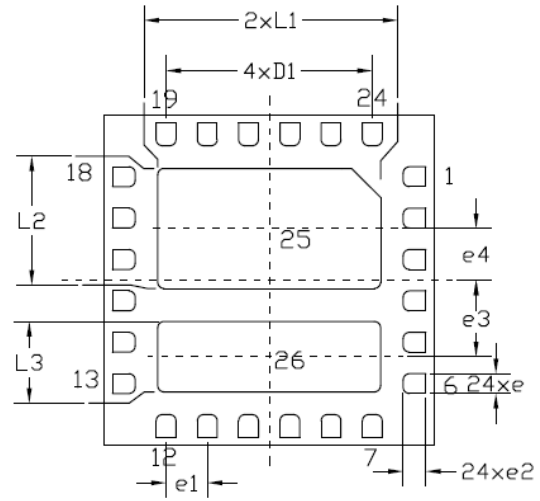

BOTTOM VIEW

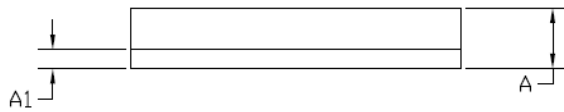

SIDE VIEW

SYMBOLS	MIN	NOM	MAX
A	-	0.73	0.83
A1	0.203 REF		
D	3.900	4.000	4.100
E	3.900	4.000	4.100
D1	2.400	2.500	2.600
e	0.19	0.24	0.29
e1	0.500 BSC		
e2	0.375 BSC		
e3	0.925 BSC		
e4	0.625 BSC		
L1	2.6	2.7	2.8
L2	1.35	1.45	1.55
L3	0.84	0.85	0.86

NOTE:

1. ALL DIMENSIONS ARE IN MILLIMETERS.
2. DIMENSION b APPLIES TO METALLIZED TERMINAL AND IS MEASURED BETWEEN 0.15mm AND 0.30mm FROM THE TERMINAL TIP. IF THE TERMINAL HAS THE OPTIONAL RADIUS ON THE OTHER END OF THE TERMINAL, THE DEMENSION b SHOULD NOT BE MEASURED IN THAT RADIUS AREA.
3. BILATERAL COPLANARITY ZONE APPLIES TO THE EXPOSED HEAT SINK SLUG AS WELL AS THE TERMINALS.

RECOMMENDED LAND PATTERN

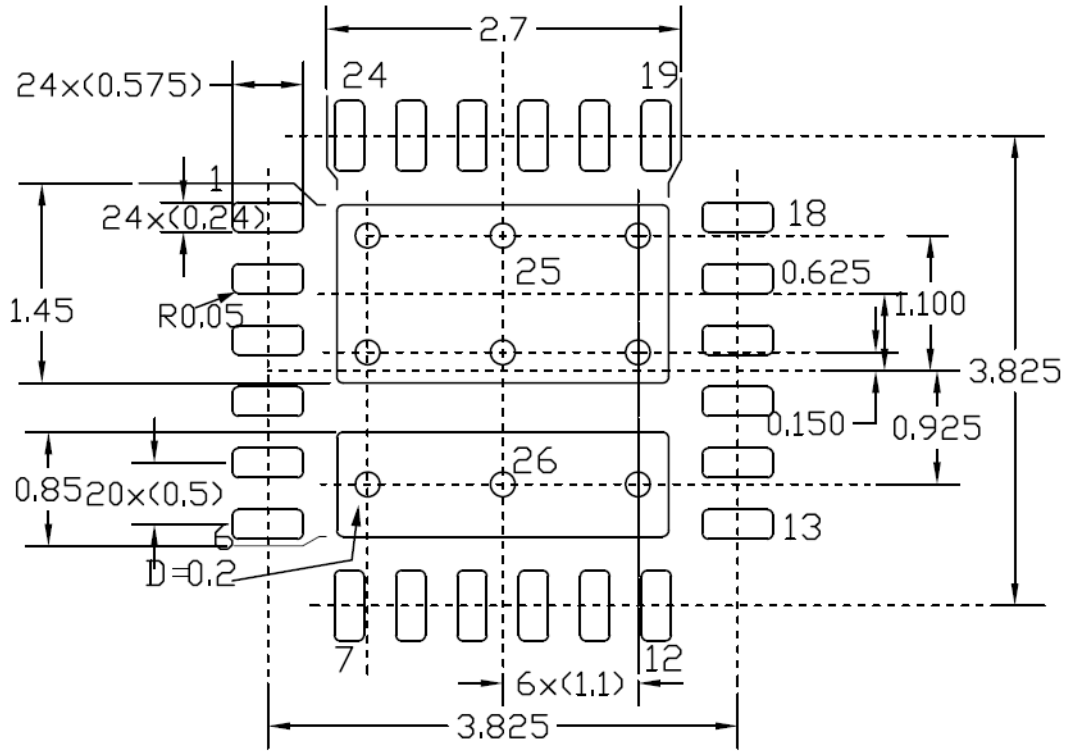

Note: All dimensions are in millimeters

TAPE AND REEL INFORMATION

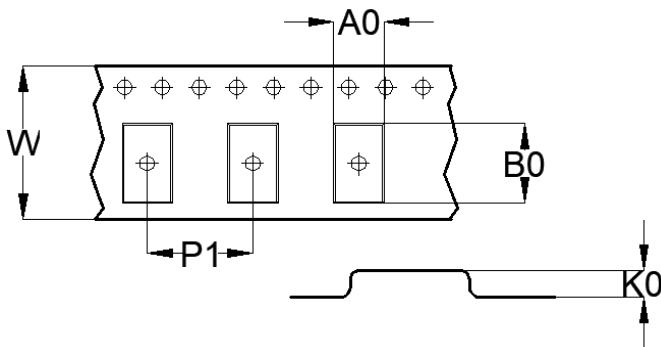
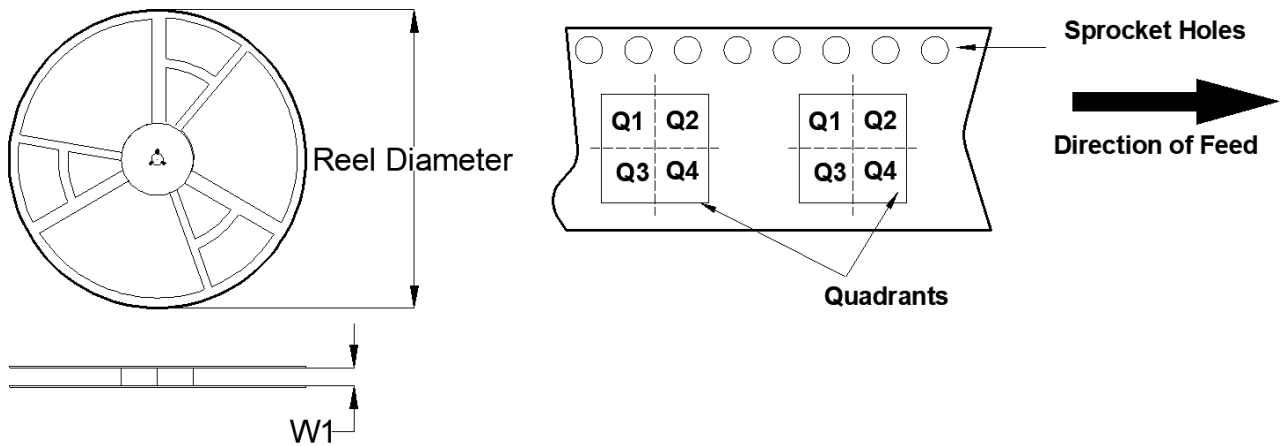

A0	Pocket width
B0	Pocket length
K0	Pocket thickness
W1	Reel Width
W	Inner width of the carrier tape
P1	Pitch between pocket centers

PKG type (mm)	Reel Diameter (mm)	Reel Width W1(mm)	A0(mm)	B0(mm)	K0(mm)	P1(mm)	W(mm)	Quad
4x4	330	12.4	4.2	4.2	1.10	8.00	12.0	Q2

Note: All the data is nominal

PIZZA BOX DIMENSION

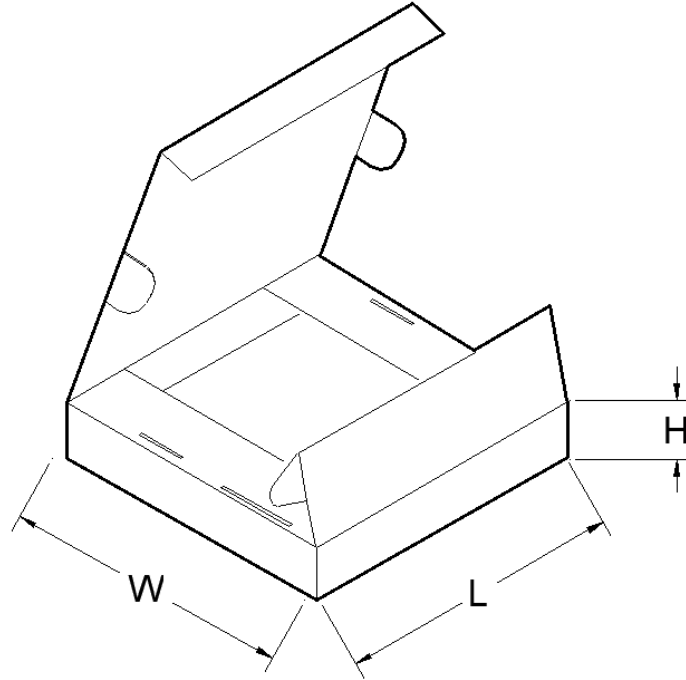

PKG type (mm)	Units/box	Length(mm)	Width(mm)	Height(mm)
4x4	5000	358	341	50

Note: All the data is nominal