

# RS31340 2.97V-16V 10A eFuse Protection Switches With Accuracy Current Monitor and Transient Overcurrent Blanking

## Features

- Wide input voltage range: 2.97V o 16V
- Integrated 5.8mΩ Pass MOSFET
- Fast over-voltage protection
  - OVLO: Adjustable overvoltage lockout
- Overcurrent protection with load current monitor output (ILM)
  - Circuit-breaker response
  - Adjustable 1.5A to 11A current limit
  - Adjustable transient blanking timer (ITIMER) to allow high transient current
- Fast-trip response for short-circuit protection
- Adjustable output slew rate (dVdt)
- Enable with adjustable input UVLO threshold
- Built-on over temperature protection
- Fault indication (FLT) or power good indication (PG)
- RoHS compliant and Green

## Description

The RS31340 devices are active circuit protection devices with an integrated MOSFET used to limit current and voltage to safe levels during fault conditions.

The current limit level can be set with a resistor between ILM and ground.

The device has over voltage protection feature which either limits the output voltage to a fixed level or cuts off the output when input over voltage fault occurs.

To limit the inrush current during device turn-on, the rising slew rate of output voltage can be set by a capacitor between dVdt and ground.

The device also offers EN on/off control and input UVLO features.

The device is available in QFN-10 pins, 2x2 mm package.

## Applications

- Hot-swap, hot-plug
- PCI and PCIe cards
- Appliances and power tools
- Smartphones and tablets
- Industrial system

## Typical Application Circuit

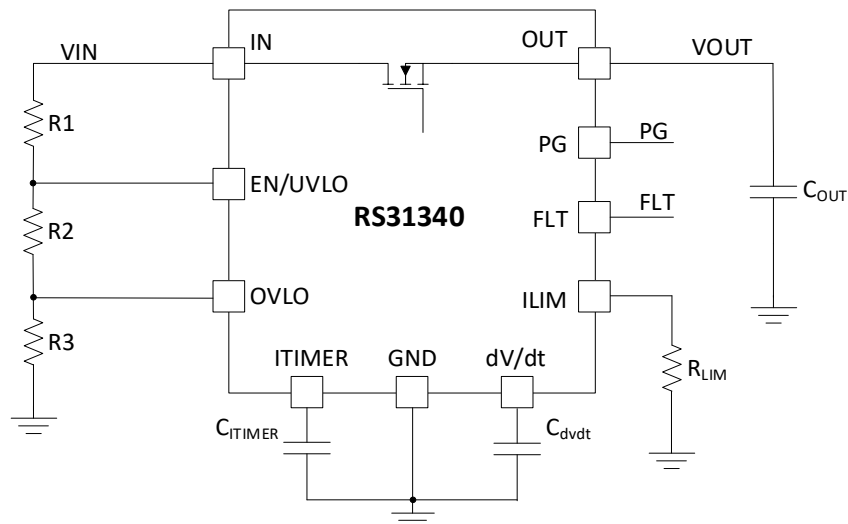

**Package Reference**

**Top View (QFN-10)**

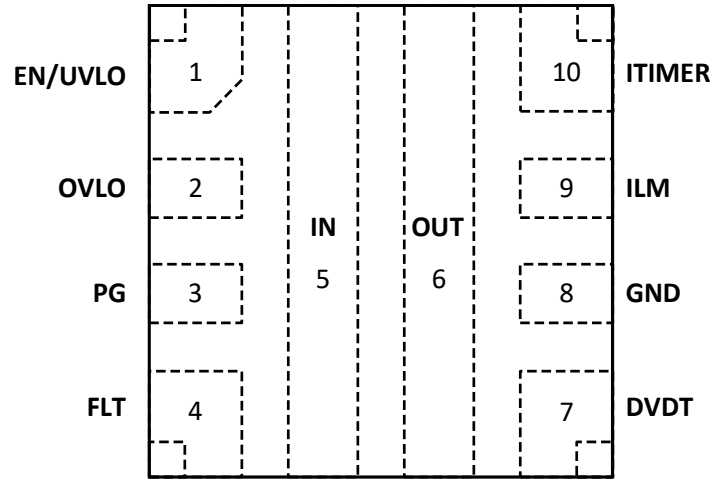

### Device Comparison Table

Part Number	Input OV	OC response	Protection
RS31340A	Adjustable OVLO	Circuit Breaker	Latch
RS31340B	Adjustable OVLO	Circuit Breaker	Auto retry

### Order Information

Part Number	Package	Size	MSL	Shipping Method	Package Marking
RS31340AR	QFN-10	2x2 mm	Level-2	3000u Tape & Reel	340A
RS31340BR	QFN-10	2x2 mm	Level-2	3000u Tape & Reel	340B

### Top Marking

RYWS
PPPP
● LLL

#### Line 1

- R: Prefix of Reed Semiconductor (R is replaced by E for engineering lot)
- Y: Year code
- W: Week code
- S: Assembly site code

#### Line 2

- PPPP: Truncated part number. Example: 340A represents the full part number RS31340A

#### Line 3

- LLL: Lot code

## Pin Description

No.	NAME	TYPE	Description
1	EN/UVLO	I	Active high enable. Pull high to enable the device, and pull low to disable the device. Connect the pin to a resistor divider from Vin to GND to set input UVLO threshold. Do not leave the pin floating.
2	OVLO	I	A resistor divider from VIN to GND can be used to set input overvoltage threshold. This pin can also be used as active low enable for the device. Do not leave floating.
3	PG	O	Open drain pin. Assert high when the internal power switch is fully turned on and VOUT exceeds PG threshold.
4	FLT	O	Open drain pin. Pulled low when a fault is detected.
5	IN	I	Input supply voltage
6	OUT	O	Output of the device
7	dVdt	O	Connect a capacitor from this pin to GND to set output voltage rising slew rate during turn-on
8	GND	G	The GND pad is used as device ground. Connect to system ground.
9	ILM	O	Dual function pin to limit and monitor the output current. An external resistor from the pin to GND sets the output current limit. The pin voltage can be used to monitor the output current. Do not leave floating.
10	ITIMER	O	A capacitor from this pin to GND sets the overcurrent blanking time during which the output current can temporarily exceed the set current limit, but lower than fast-trip threshold. Leave the pin open for the fastest response to overcurrent events.

**PACKAGE DIMENSION**

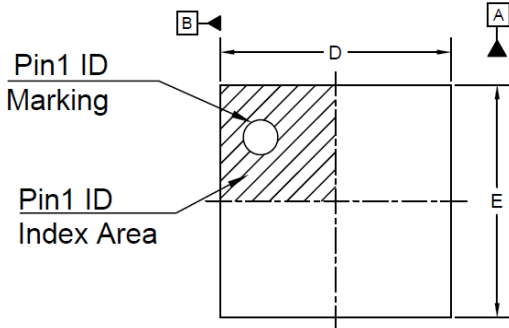

TOP VIEW

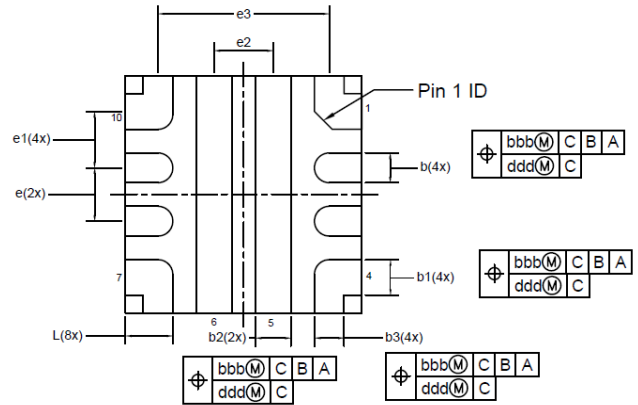

BOTTOM VIEW

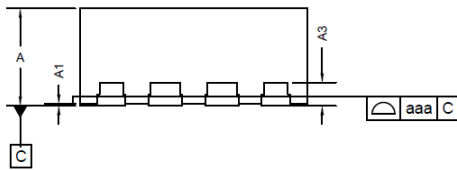

SIDE VIEW

REF	MIN	NOM	MAX
A	0.750	0.850	0.950
A1	0.000		0.050
A3	0.203 REF		
D	1.900	2.000	2.100
E	1.900	2.000	2.100
b	0.200	0.250	0.300
b1	0.250	0.300	0.350
b2	0.250	0.300	0.350
b3	0.200	0.250	0.300
e	0.450 BSC		
e1	0.475 BSC		
e2	0.500 REF		
e3	1.450 REF		
L	0.300	0.400	0.500
Tol of Form & Position			
aaa	0.08		
bbb	0.1		
ddd	0.05		

NOTE:

1. ALL DIMENSIONS ARE IN MILLIMETERS.
2. DIMENSION b APPLIES TO METALLIZED TERMINAL AND IS MEASURED BETWEEN 0.15mm AND 0.30mm FROM THE TERMINAL TIP. IF THE TERMINAL HAS THE OPTIONAL RADIUS ON THE OTHER END OF THE TERMINAL, THE DEMENSION b SHOULD NOT BE MEASURED IN THAT RADIUS AREA.
3. BILATERAL COPLANARITY ZONE APPLIES TO THE EXPOSED HEAT SINK SLUG AS WELL AS THE TERMINALS.

RECOMMENDED LAND PATTERN

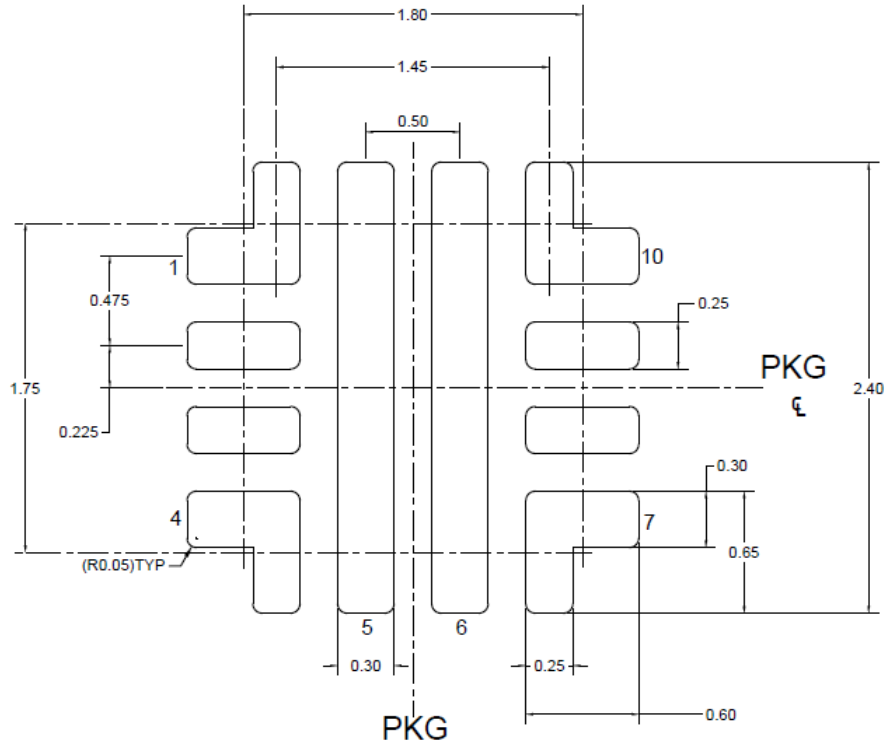

Note: All the data is nominal

**TAPE AND REEL INFORMATION**

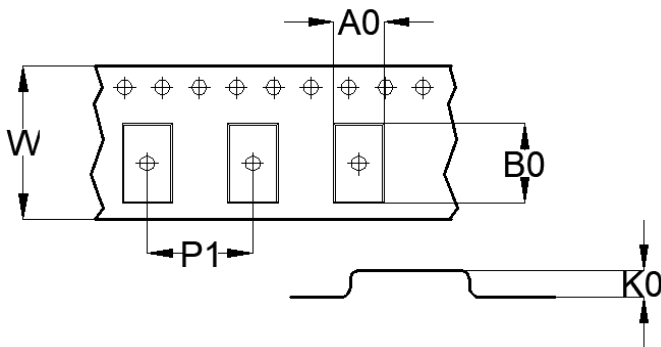
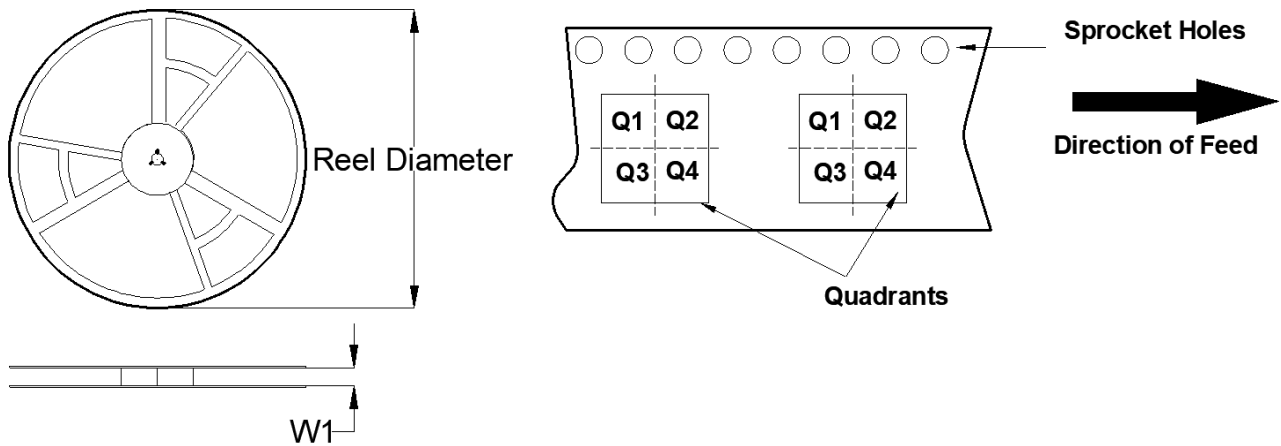

A0	Pocket width
B0	Pocket length
K0	Pocket thickness
W1	Reel Width
W	Inner width of the carrier tape
P1	Pitch between pocket centers

PKG type (mm)	Reel Diameter (mm)	Reel Width W1(mm)	A0(mm)	B0(mm)	K0(mm)	P1(mm)	W(mm)	Quad
2x2	178	9.5	2.2	2.2	1.1	4.0	8.0	Q2

Note: All the data is nominal

**PIZZA BOX DIMENSION**

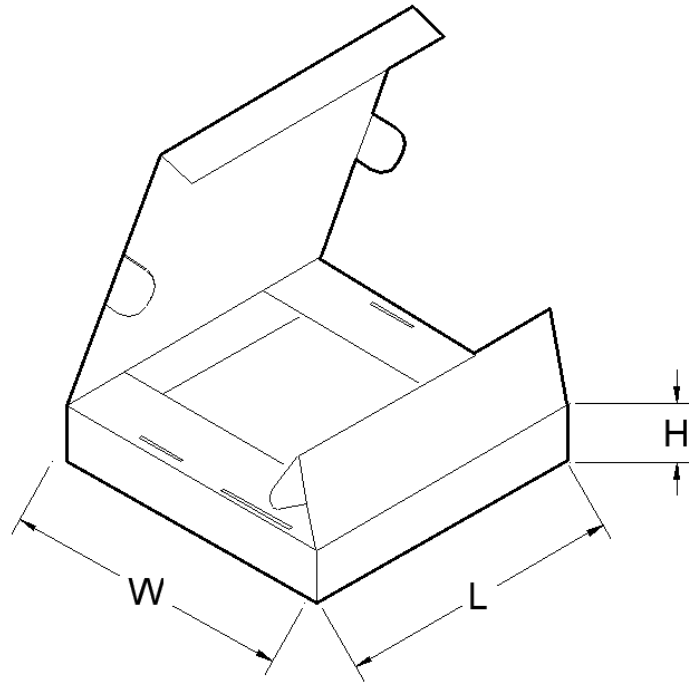

PKG type (mm)	Units/box	Length(mm)	Width(mm)	Height(mm)
2x2	3000	205	200	25

Note: All the data is nominal