

RS53317 2.85V to 16V Input, 6A Sync Step-Down Converter with Programmable Switching Frequency and Over Current Limit

Features

- Robust Constant On Time (RCOT™) Control with fast transient response
- Input Voltage Range: 2.85V to 16V with external bias, or 4V to 16V with internal bias
- Output Voltage Range: 0.6V to 6.0V for RS53317L. 0.9V to 6.0V for RS53317H
- 6A continuous output current
- Excellent load and line regulations with 0.5% voltage accuracy
- Stable with Zero ESR Output Capacitor
- Output Voltage Discharge
- Mode Selection Between Pulse Skip and CCM at Light Load
- PGOOD Active Clamped at Low Level during Power Failure
- Programmable Switch Valley Current Limit
- Adjustable Switching Frequency: 600kHz, 800kHz, 1100kHz, 2000kHz
- OCP, NOCP, UVP, UVLO, OTP and OVP
- 2mm x 3mm 14-Pin QFN Package
- RoHS compliant and Green

Applications

- Telecom/Datacom
- Computing and Servers

- Point of Load Module
- Standard 12V Rail Supplies
- High-end TV
- Game Consoles and Graphic Cards

Description

The RS53317 is a high-power density, fully integrated synchronous buck converter. It has a wide input voltage range and can support up to 6A continuous output current at defined conditions. LDO is integrated internally, which is very suitable for single input supply condition. External bias is optional for maximizing efficiency. A differential sensing scheme and an internal feedback reference voltage achieve $\pm 1\%$ tolerance over full temperature range and, in conjunction, they perform an excellent line and load regulation.

Switching frequency can be easily adjusted from 600kHz, 800kHz, 1100kHz and 2000kHz. The RS53317 uses patented Robust Constant On Time (RCOT™) control scheme with fast transient response. Pure MLCC output capacitors can be used to save space and cost.

RS53317 has full protection features. OCP, UVP, UVLO, OTP are non-latch mode for RS53317L and latch-off mode for RS53317H. OVP is latch-off mode for both RS53317L and RS53317H.

The RS53317 is available in a 2mm x 3mm 14-Pin QFN package.

Typical Application Circuit

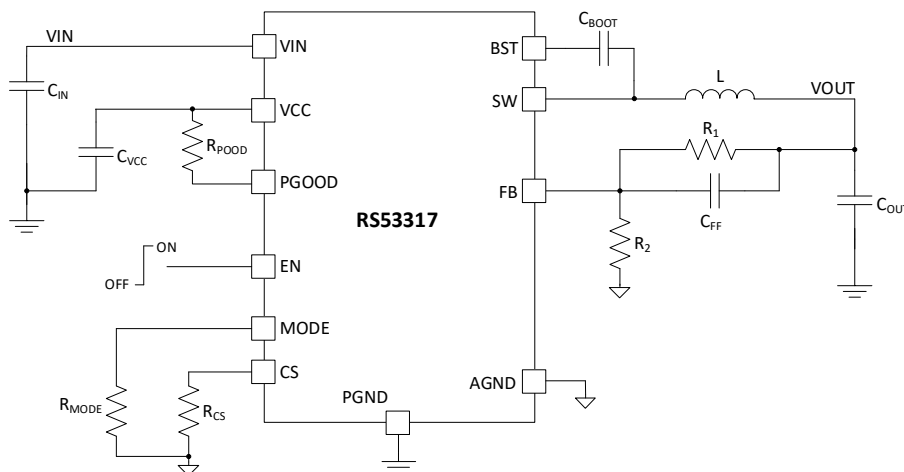

Package Reference

Top View

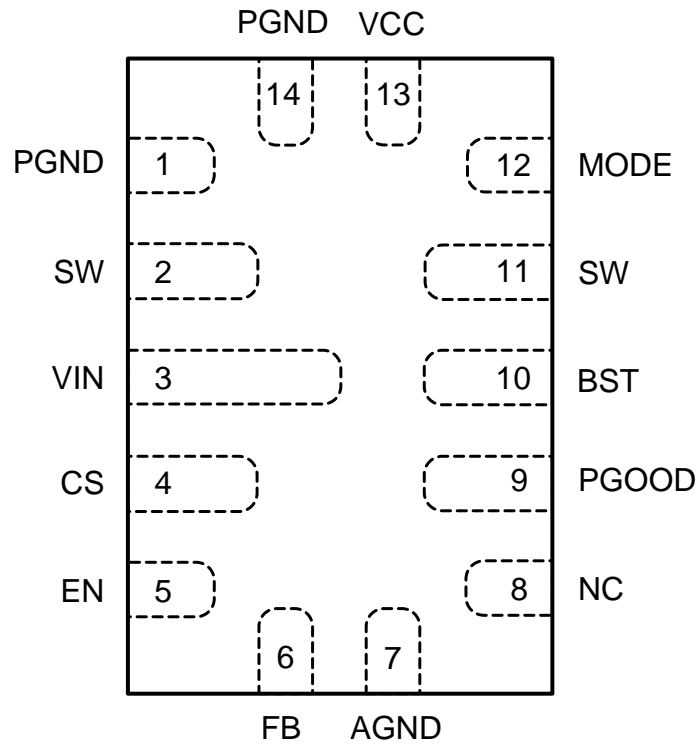

QFN-14 (2x3mm)

Part Number and Order Information

Part Number	VREF	Package	MSL	Shipping Method	Package Marking
RS53317LT	0.6V	QFN-14	Level-1	500u Tape & Reel	R3317L
RS53317LR	0.6V			4000u Tape & Reel	R3317L
RS53317HT	0.9V			500u Tape & Reel	R3317H
RS53317HR	0.9V			4000u Tape & Reel	R3317H

Top Marking

RSYYWW
PPPPPP
● LLLLLS

Line 1

- RS: Prefix of Reed Semiconductor (RS is replaced by RE for engineering lot)
- YY: Year code
- WW: Week code

Line 2

- PPPPPP: Truncated part number

Line 3

- LLLLL: Lot code
- S: Assembly site code

Pin Description

Pin Number	Name	Description
1, 14	PGND	System Ground. Power ground of the power stage.
2, 11	SW	Switch node of power stage. Connect SW pin the inductor with wide copper plane.
3	VIN	Supply voltage. Input to the power stage and internal LDO. Place input capacitor close to VIN pin in layout.
4	CS	Current limit setting. Connect a resistor to AGND to set the inductor valley current limit trip point.
5	EN	Enable pin. Drive EN high to initiate VCC internal LDO and soft start. Do not float this pin.
6	FB	Output remote sense feedback. Use the external resistor divider from the output to AGND tapped to FB to set output voltage. Place the resistor divider close to FB in layout.
7	AGND	Signal logic ground. A Kelvin connection to PGND is required.
8	NC	Not connected internally.
9	PGOOD	Power good output with open drain.
10	BST	Bootstrap connection. A capacitor connected between SW and BST is required to form a floating supply across the high-side switch driver. Use 0.1uF to 1uF value for boot capacitor.
12	MODE	Operation mode selection. Connect a resistor to AGND to set switching frequency and DCM/FCCM operation.
13	VCC	Internal 3.3V LDO output. Use 1uF or larger value for VCC capacitor. Place VCC capacitor close to VCC pin in layout.

PACKAGE DIMENSION

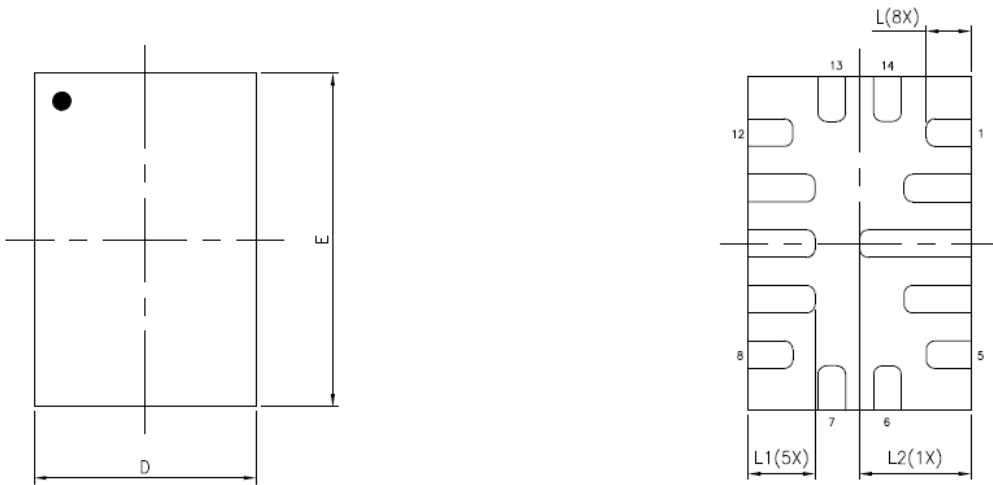

TOP VIEW

BOTTOM VIEW

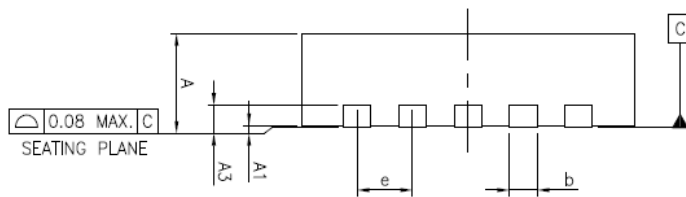

SIDE VIEW

PKG CODE	VQFN(YL23)		
SYMBOLS	MIN.	NOM.	MAX.
A	0.80	0.85	0.90
A1	0.00	0.02	0.05
A3	0.203 REF		
b	0.20	0.25	0.30
D	1.90	2.00	2.10
E	2.90	3.00	3.10
e	0.50 BSC		
L	0.35	0.40	0.45
L1	0.55	0.60	0.65
L2	0.95	1.00	1.05

NOTES :

1. ALL DIMENSIONS ARE IN MILLIMETERS.
2. DIMENSION b APPLIES TO METALLIZED TERMINAL AND IS MEASURED BETWEEN 0.15mm AND 0.30mm FROM THE TERMINAL TIP. IF THE TERMINAL HAS THE OPTIONAL RADIUS ON THE OTHER END OF THE TERMINAL, THE DIMENSION b SHOULD NOT BE MEASURED IN THAT RADIUS AREA.
3. BILATERAL COPLANARITY ZONE APPLIES TO THE EXPOSED HEAT SINK SLUG AS WELL AS THE TERMINALS.

RECOMMENDED LAND PATTERN

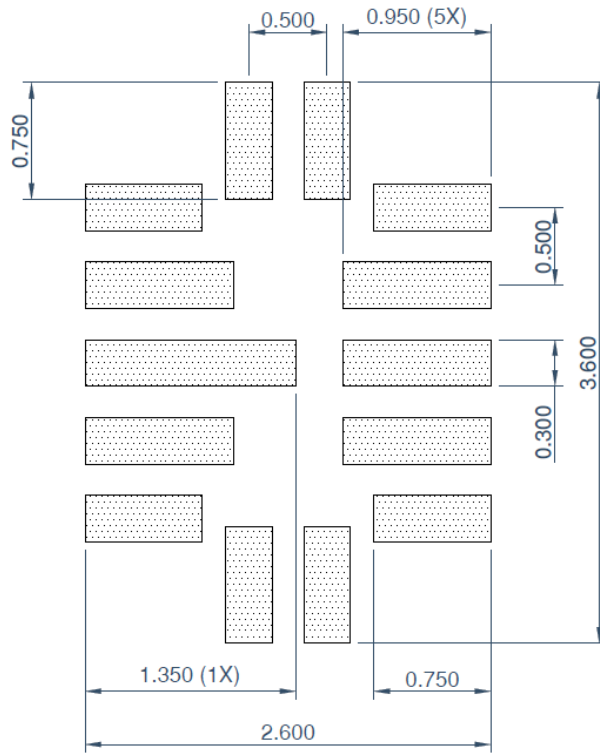

TAPE AND REEL INFORMATION

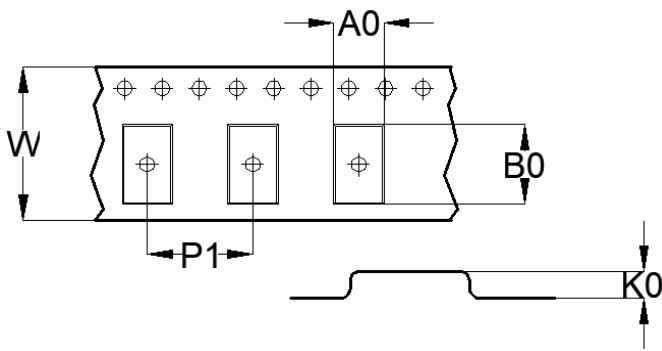
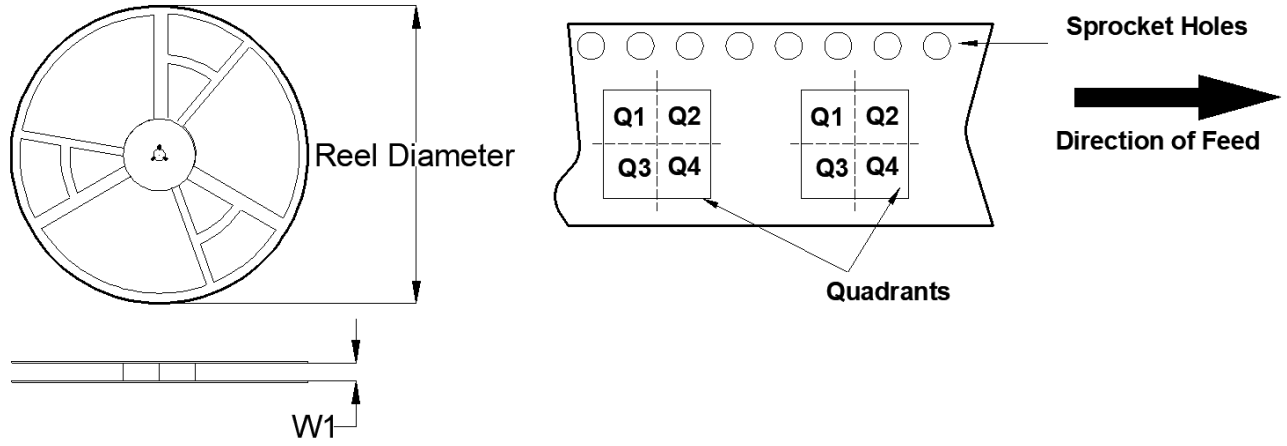

A0	Pocket width
B0	Pocket length
K0	Pocket thickness
W1	Reel Width
W	Inner width of the carrier tape
P1	Pitch between pocket centers

PKG type (mm)	Reel Diameter (mm)	Reel Width W1(mm)	A0(mm)	B0(mm)	K0(mm)	P1(mm)	W(mm)	Quad
2x3	330	12.8	2.2	3.2	1.10	4.00	12.0	Q1

Note: All the data is nominal

PIZZA BOX DIMENSION

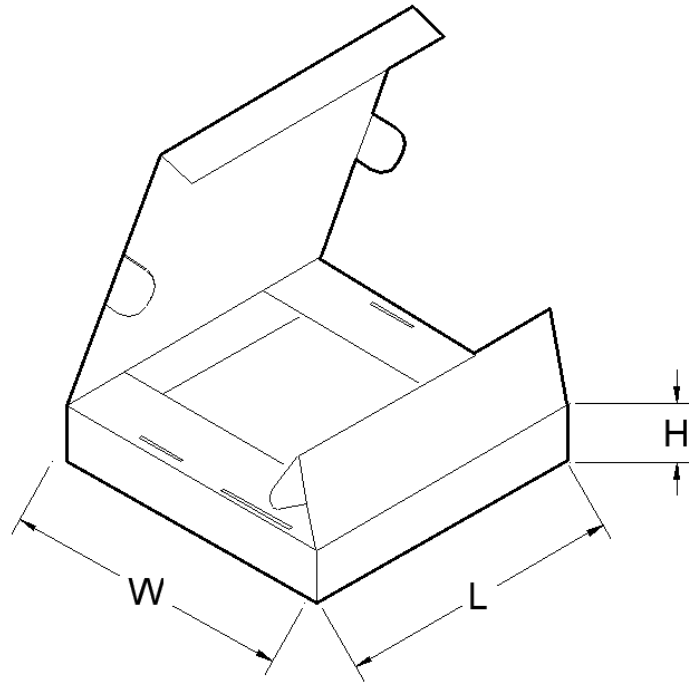

PKG type (mm)	Units/box	Length(mm)	Width(mm)	Height(mm)
2x3	4000	355	340	50

Note: All the data is nominal