

Mechanical Dimensions: Inches [mm]

Tolerances ± 0.012 [0.3] Unless Otherwise Specified

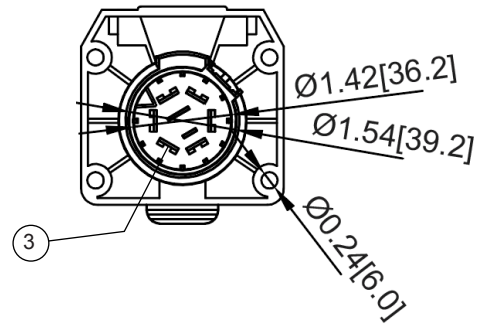
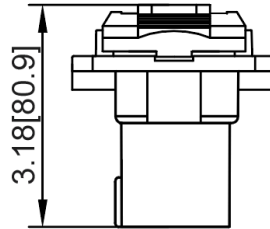
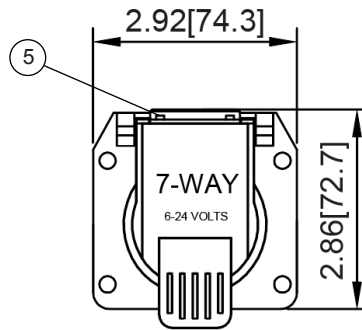
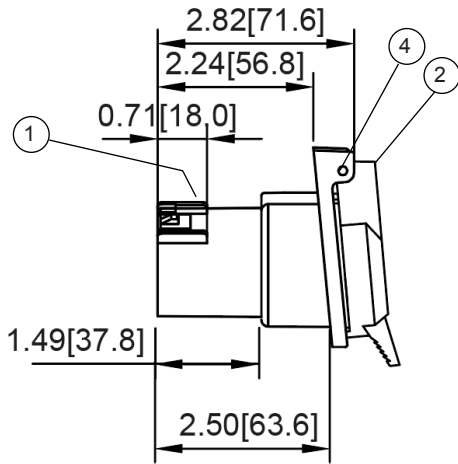

Wiring Color Codes

A.T.A. & S.A.E WIRING CODES RECOMMENDED STANDARD			
CIRCUITS	POLE WIRING COLOR CODE		RECOMMENDED WIRE GAUGE
Ground Return	White		10 GA
Electric Brake	Blue		12 GA
Tail, License and Running Lights	Green		14 GA
Battery Charge	Black		10 GA
Stop & Left Hand Turn Signal	Red		14 GA
Stop & Right Hand Turn Signal	Brown		14 GA
Auxiliary Circuit	Yellow		14 GA

Material Specifications

ITEM#	NAME	MATERIAL
1	HOUSING	Nylon with Fiberglass
2	COVER	Nylon with Fiberglass
3	TERMINALS	COPPER
4	SPRING	WHITE IRON
5	PLUG	WHITE IRON

Rev	Date of issue	Revision Notes	Designed	Approved
A	11-09-2020	Initial Drawing	RC	OF