

XMC4700 / XMC4800

Microcontroller Series
for Industrial Applications

XMC4000 Family

ARM[®] Cortex[®]-M4
32-bit processor core

Data Sheet

V1.2 2023-04

Microcontrollers

Edition 2023-04

**Published by
Infineon Technologies AG
81726 Munich, Germany**

**© 2023 Infineon Technologies AG
All Rights Reserved.**

Legal Disclaimer

The information given in this document shall in no event be regarded as a guarantee of conditions or characteristics. With respect to any examples or hints given herein, any typical values stated herein and/or any information regarding the application of the device, Infineon Technologies hereby disclaims any and all warranties and liabilities of any kind, including without limitation, warranties of non-infringement of intellectual property rights of any third party.

Information

For further information on technology, delivery terms and conditions and prices, please contact the nearest Infineon Technologies Office (www.infineon.com).

Warnings

Due to technical requirements, components may contain dangerous substances. For information on the types in question, please contact the nearest Infineon Technologies Office.

Infineon Technologies components may be used in life-support devices or systems only with the express written approval of Infineon Technologies, if a failure of such components can reasonably be expected to cause the failure of that life-support device or system or to affect the safety or effectiveness of that device or system. Life support devices or systems are intended to be implanted in the human body or to support and/or maintain and sustain and/or protect human life. If they fail, it is reasonable to assume that the health of the user or other persons may be endangered.

XMC4700 / XMC4800

Microcontroller Series
for Industrial Applications

XMC4000 Family

ARM[®] Cortex[®]-M4
32-bit processor core

Data Sheet

V1.2 2023-04

XMC4[78]00 Data Sheet

Revision History: V1.2 2023-04

Previous Versions:

V1.1 2018-09

V1.0 2016-01

V0.7 2015-10 (preliminary)

Page	Subjects
V1.2, 2023	
131	Added PG-LQFP-144-28 and PG-LQFP-100-29 details in Table 71.
135	Added package diagram: PG-LQFP-100-29.
136	Added package diagram: PG-LQFP-144-28.

Trademarks

C166™, TriCore™, XMC™ and DAVE™ are trademarks of Infineon Technologies AG.
ARM®, ARM Powered®, Cortex®, Thumb® and AMBA® are registered trademarks of ARM, Limited.

CoreSight™, ETM™, Embedded Trace Macrocell™ and Embedded Trace Buffer™ are trademarks of ARM, Limited.

Synopsys™ is a trademark of Synopsys, Inc.

We Listen to Your Comments

Is there any information in this document that you feel is wrong, unclear or missing?
Your feedback will help us to continuously improve the quality of this document.
Please send your proposal (including a reference to this document) to:

mcdocu.comments@infineon.com



Table of Contents

1	Summary of Features	8
1.1	Ordering Information	10
1.2	Device Types	11
1.3	Device Type Features	12
1.4	Definition of Feature Variants	15
1.5	Identification Registers	16
2	General Device Information	17
2.1	Logic Symbols	17
2.2	Pin Configuration and Definition	20
2.2.1	Package Pin Summary	23
2.2.2	Port I/O Functions	32
2.2.2.1	Port I/O Function Table	33
2.3	Power Connection Scheme	41
3	Electrical Parameters	43
3.1	General Parameters	43
3.1.1	Parameter Interpretation	43
3.1.2	Absolute Maximum Ratings	44
3.1.3	Pin Reliability in Overload	45
3.1.4	Pad Driver and Pad Classes Summary	48
3.1.5	Operating Conditions	49
3.2	DC Parameters	50
3.2.1	Input/Output Pins	50
3.2.2	Analog to Digital Converters (VADC)	57
3.2.3	Digital to Analog Converters (DAC)	61
3.2.4	Out-of-Range Comparator (ORC)	65
3.2.5	Die Temperature Sensor	67
3.2.6	USB OTG Interface DC Characteristics	68
3.2.7	Oscillator Pins	70
3.2.8	Power Supply Current	74
3.2.9	Flash Memory Parameters	78
3.3	AC Parameters	80
3.3.1	Testing Waveforms	80
3.3.2	Power-Up and Supply Monitoring	81
3.3.3	Power Sequencing	82
3.3.4	Phase Locked Loop (PLL) Characteristics	84
3.3.5	Internal Clock Source Characteristics	85
3.3.6	JTAG Interface Timing	87
3.3.7	Serial Wire Debug Port (SW-DP) Timing	89
3.3.8	Embedded Trace Macro Cell (ETM) Timing	90
3.3.9	Peripheral Timing	91

Table of Contents

3.3.9.1	Delta-Sigma Demodulator Digital Interface Timing	91
3.3.9.2	Synchronous Serial Interface (USIC SSC) Timing	92
3.3.9.3	Inter-IC (IIC) Interface Timing	95
3.3.9.4	Inter-IC Sound (IIS) Interface Timing	97
3.3.9.5	SDMMC Interface Timing	99
3.3.10	EBU Timing	107
3.3.10.1	EBU Asynchronous Timing	107
3.3.10.2	EBU Burst Mode Access Timing	114
3.3.10.3	EBU Arbitration Signal Timing	116
3.3.10.4	EBU SDRAM Access Timing	117
3.3.11	USB Interface Characteristics	121
3.3.12	Ethernet Interface (ETH) Characteristics	122
3.3.12.1	ETH Measurement Reference Points	122
3.3.12.2	ETH Management Signal Parameters (ETH_MDC, ETH_MDIO)	123
3.3.12.3	ETH MII Parameters	124
3.3.12.4	ETH RMII Parameters	125
3.3.13	EtherCAT (ECAT) Characteristics	126
3.3.13.1	ECAT Measurement Reference Points	126
3.3.13.2	ETH Management Signal Parameters (MCLK, MDIO)	126
3.3.13.3	MII Timing TX Characteristics	127
3.3.13.4	MII Timing RX Characteristics	129
3.3.13.5	Sync/Latch Timings	130
4	Package and Reliability	131
4.1	Package Parameters	131
4.1.1	Thermal Considerations	132
4.2	Package Outlines	133
5	Quality Declarations	137

About this Document

This Data Sheet is addressed to embedded hardware and software developers. It provides the reader with detailed descriptions about the ordering designations, available features, electrical and physical characteristics of the XMC4[12]00 series devices.

The document describes the characteristics of a superset of the XMC4[12]00 series devices. For simplicity, the various device types are referred to by the collective term XMC4[12]00 throughout this manual.

XMC4000 Family User Documentation

The set of user documentation includes:

- **Reference Manual**
 - describes the functionality of the superset of devices.
- **Data Sheets**
 - list the complete ordering designations, available features and electrical characteristics of derivative devices.
- **Errata Sheets**
 - list deviations from the specifications given in the related Reference Manual or Data Sheets. Errata Sheets are provided for the superset of devices.

Attention: Please consult all parts of the documentation set to attain consolidated knowledge about your device.

Application related guidance is provided by **Users Guides** and **Application Notes**.

Please refer to <http://www.infineon.com/xmc4000> to get access to the latest versions of those documents.

1 Summary of Features

The XMC4[78]00 devices are members of the XMC4000 Family of microcontrollers based on the ARM Cortex-M4 processor core. The XMC4000 is a family of high performance and energy efficient microcontrollers optimized for Industrial Connectivity, Industrial Control, Power Conversion, Sense & Control.

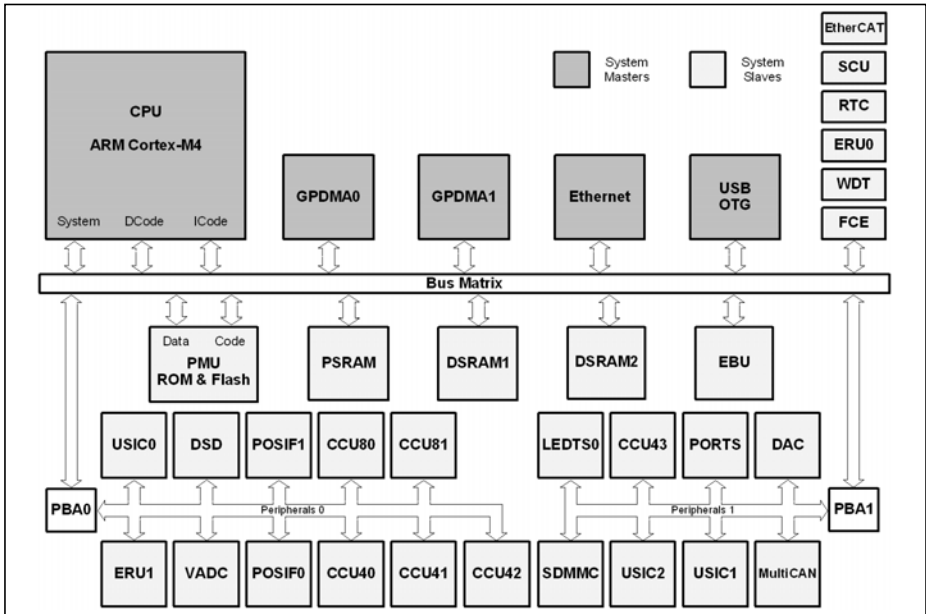

Figure 1 System Block Diagram

CPU Subsystem

- CPU Core
 - High Performance 32-bit ARM Cortex-M4 CPU
 - 16-bit and 32-bit Thumb2 instruction set
 - DSP/MAC instructions
 - System timer (SysTick) for Operating System support
- Floating Point Unit
- Memory Protection Unit
- Nested Vectored Interrupt Controller
- General Purpose DMA with up-to 12 channels
- Event Request Unit (ERU) for programmable processing of external and internal service requests
- Flexible CRC Engine (FCE) for multiple bit error detection

On-Chip Memories

- 16 KB on-chip boot ROM
- 96 KB on-chip high-speed program memory
- 128 KB on-chip high speed data memory
- 128 KB on-chip high-speed communication memory
- 2,048 KB on-chip Flash Memory with 8 KB instruction cache

Communication Peripherals

- Ethernet MAC module capable of 10/100 Mbit/s transfer rates
- EtherCATSlave interface (ECAT) capable of 100 Mbit/s transfer rates with 2 MII ports, 8 Fieldbus Memory Management Units (FMMU), 8 Sync Manager, 64 bit distributed clocks
- Universal Serial Bus, USB 2.0 host, Full-Speed OTG, with integrated PHY
- Controller Area Network interface (MultiCAN), Full-CAN/Basic-CAN with 6 nodes, 256 message objects (MO), data rate up to 1 MBaud
- Six Universal Serial Interface Channels (USIC), providing 6 serial channels, usable as UART, double-SPI, quad-SPI, IIC, IIS and LIN interfaces
- LED and Touch-Sense Controller (LEDTS) for Human-Machine interface
- SD and Multi-Media Card interface (SDMMC) for data storage memory cards
- External Bus Interface Unit (EBU) enabling communication with external memories and off-chip peripherals

Analog Frontend Peripherals

- Four Analog-Digital Converters (VADC) of 12-bit resolution, 8 channels each, with input out-of-range comparators
- Delta Sigma Demodulator with four channels, digital input stage for A/D signal conversion
- Digital-Analog Converter (DAC) with two channels of 12-bit resolution

Industrial Control Peripherals

- Two Capture/Compare Units 8 (CCU8) for motor control and power conversion
- Four Capture/Compare Units 4 (CCU4) for use as general purpose timers
- Two Position Interfaces (POSIF) for servo motor positioning
- Window Watchdog Timer (WDT) for safety sensitive applications
- Die Temperature Sensor (DTS)
- Real Time Clock module with alarm support
- System Control Unit (SCU) for system configuration and control

Input/Output Lines

- Programmable port driver control module (PORTS)
- Individual bit addressability
- Tri-stated in input mode
- Push/pull or open drain output mode
- Boundary scan test support over JTAG interface

On-Chip Debug Support

- Full support for debug features: 8 breakpoints, CoreSight, trace
- Various interfaces: ARM-JTAG, SWD, single wire trace

1.1 Ordering Information

The ordering code for an Infineon microcontroller provides an exact reference to a specific product. The code "XMC4<DDD>-<Z><PPP><T><FFFF>" identifies:

- <DDD> the derivatives function set
- <Z> the package variant
 - E: LFBGA
 - F: LQFP
 - Q: VQFN
- <PPP> package pin count
- <T> the temperature range:
 - F: -40°C to 85°C
 - K: -40°C to 125°C
- <FFFF> the Flash memory size.

For ordering codes for the XMC4[78]00 please contact your sales representative or local distributor.

This document describes several derivatives of the XMC4[78]00 series, some descriptions may not apply to a specific product. Please see [Table 1](#).

For simplicity the term **XMC4[78]00** is used for all derivatives throughout this document.

1.2 Device Types

These device types are available and can be ordered through Infineon's direct and/or distribution channels.

Table 1 Synopsis of XMC4[78]00 Device Types

Derivative ¹⁾	Package	Flash Kbytes	SRAM Kbytes
XMC4700-E196x2048	PG-LFBGA-196	2048	352
XMC4700-F144x2048	PG-LQFP-144	2048	352
XMC4700-F100x2048	PG-LQFP-100	2048	352
XMC4700-E196x1536	PG-LFBGA-196	1536	276
XMC4700-F144x1536	PG-LQFP-144	1536	276
XMC4700-F100x1536	PG-LQFP-100	1536	276
XMC4800-E196x2048	PG-LFBGA-196	2048	352
XMC4800-F144x2048	PG-LQFP-144	2048	352
XMC4800-F100x2048	PG-LQFP-100	2048	352
XMC4800-E196x1536	PG-LFBGA-196	1536	276
XMC4800-F144x1536	PG-LQFP-144	1536	276
XMC4800-F100x1536	PG-LQFP-100	1536	276
XMC4800-E196x1024	PG-LFBGA-196	1024	200
XMC4800-F144x1024	PG-LQFP-144	1024	200
XMC4800-F100x1024	PG-LQFP-100	1024	200

1) x is a placeholder for the supported temperature range.

1.3 Device Type Features

The following table lists the available features per device type.

Table 2 Features of XMC4[78]00 Device Types

Derivative ¹⁾	LED TS Intf.	SD MMC Intf.	EBU Intf. ²⁾	ETH Intf. ³⁾	ECAT Slave Intf.	USB Intf.	USIC Chan.	MultiCAN Nodes, MO
XMC4700-E196x2048	1	1	SDM	MR	-	1	3 x 2	N[0..5] MO[0..255]
XMC4700-F144x2048	1	1	SDM	MR	-	1	3 x 2	N[0..5] MO[0..255]
XMC4700-F100x2048	1	1	M16	R	-	1	3 x 2	N[0..5] MO[0..255]
XMC4700-E196x1536	1	1	SDM	MR	-	1	3 x 2	N[0..5] MO[0..255]
XMC4700-F144x1536	1	1	SDM	MR	-	1	3 x 2	N[0..5] MO[0..255]
XMC4700-F100x1536	1	1	M16	R	-	1	3 x 2	N[0..5] MO[0..255]
XMC4800-E196x2048	1	1	SDM	MR	2 x MII	1	3 x 2	N[0..5] MO[0..255]
XMC4800-F144x2048	1	1	SDM	MR	2 x MII	1	3 x 2	N[0..5] MO[0..255]
XMC4800-F100x2048	1	1	M16	R	2 x MII	1	3 x 2	N[0..5] MO[0..255]
XMC4800-E196x1536	1	1	SDM	MR	2 x MII	1	3 x 2	N[0..5] MO[0..255]
XMC4800-F144x1536	1	1	SDM	MR	2 x MII	1	3 x 2	N[0..5] MO[0..255]
XMC4800-F100x1536	1	1	M16	R	2 x MII	1	3 x 2	N[0..5] MO[0..255]
XMC4800-E196x1024	1	1	SDM	MR	2 x MII	1	3 x 2	N[0..5] MO[0..255]
XMC4800-F144x1024	1	1	SDM	MR	2 x MII	1	3 x 2	N[0..5] MO[0..255]
XMC4800-F100x1024	1	1	M16	R	2 x MII	1	3 x 2	N[0..5] MO[0..255]

Summary of Features

- 1) x is a placeholder for the supported temperature range.
- 2) Memory types supported S=SDRAM, D=DEMUX, M=MUX 16-bit and 32-bit, M16=MUX 16-bit
- 3) Supported interfaces, M=MII, R=RMII.

Table 3 Features of XMC4[78]00 Device Types

Derivative¹⁾	ADC Chan.	DSD Chan.	DAC Chan.	CCU4 Slice	CCU8 Slice	POSIF Intf.
XMC4700-E196x2048	32	4	2	4 x 4	2 x 4	2
XMC4700-F144x2048	32	4	2	4 x 4	2 x 4	2
XMC4700-F100x2048	24	4	2	4 x 4	2 x 4	2
XMC4700-E196x1536	32	4	2	4 x 4	2 x 4	2
XMC4700-F144x1536	32	4	2	4 x 4	2 x 4	2
XMC4700-F100x1536	24	4	2	4 x 4	2 x 4	2
XMC4800-E196x2048	32	4	2	4 x 4	2 x 4	2
XMC4800-F144x2048	32	4	2	4 x 4	2 x 4	2
XMC4800-F100x2048	24	4	2	4 x 4	2 x 4	2
XMC4800-E196x1536	32	4	2	4 x 4	2 x 4	2
XMC4800-F144x1536	32	4	2	4 x 4	2 x 4	2
XMC4800-F100x1536	24	4	2	4 x 4	2 x 4	2
XMC4800-E196x1024	32	4	2	4 x 4	2 x 4	2
XMC4800-F144x1024	32	4	2	4 x 4	2 x 4	2
XMC4800-F100x1024	24	4	2	4 x 4	2 x 4	2

1) x is a placeholder for the supported temperature range.

1.4 Definition of Feature Variants

The XMC4[78]00 types are offered with several memory sizes and number of available VADC channels. **Table 4** describes the location of the available Flash memory, **Table 5** describes the location of the available SRAMs, **Table 6** the available VADC channels.

Table 4 Flash Memory Ranges

Total Flash Size	Cached Range	Uncached Range
1,024 Kbytes	0800 0000 _H – 080F FFFF _H	0C00 0000 _H – 0C0F FFFF _H
1,536 Kbytes	0800 0000 _H – 0817 FFFF _H	0C00 0000 _H – 0C17 FFFF _H
2,048 Kbytes	0800 0000 _H – 081F FFFF _H	0C00 0000 _H – 0C1F FFFF _H

Table 5 SRAM Memory Ranges

Total SRAM Size	Program SRAM	System Data SRAM	Communication Data SRAM
200 Kbytes	1FFE E000 _H – 1FFF FFFF _H	2000 0000 _H – 2001 FFFF _H	–
276 Kbytes	1FFE 8000 _H – 1FFF FFFF _H	2000 0000 _H – 2001 FFFF _H	2002 0000 _H – 2002 CFFF _H
352 Kbytes	1FFE 8000 _H – 1FFF FFFF _H	2000 0000 _H – 2001 FFFF _H	2002 0000 _H – 2003 FFFF _H

Table 6 ADC Channels¹⁾

Package	VADC G0	VADC G1	VADC G2	VADC G3
PG-LQFP-144 PG-LFBGA-196	CH0..CH7	CH0..CH7	CH0..CH7	CH0..CH7
PG-LQFP-100	CH0..CH7	CH0..CH7	CH0..CH3	CH0..CH3

1) Some pins in a package may be connected to more than one channel. For the detailed mapping see the Port I/O Function table.

1.5 Identification Registers

The identification registers allow software to identify the marking.

Table 7 XMC4700 Identification Registers

Register Name	Value	Marking
SCU_IDCHIP	0004 7001 _H	EES-AA, ES-AA, AA
JTAG IDCODE	101D F083 _H	EES-AA, ES-AA, AA

Table 8 XMC4800 Identification Registers

Register Name	Value	Marking
SCU_IDCHIP	0004 8001 _H	EES-AA, ES-AA, AA
JTAG IDCODE	101D F083 _H	EES-AA, ES-AA, AA

2 General Device Information

This section summarizes the logic symbols and package pin configurations with a detailed list of the functional I/O mapping.

2.1 Logic Symbols

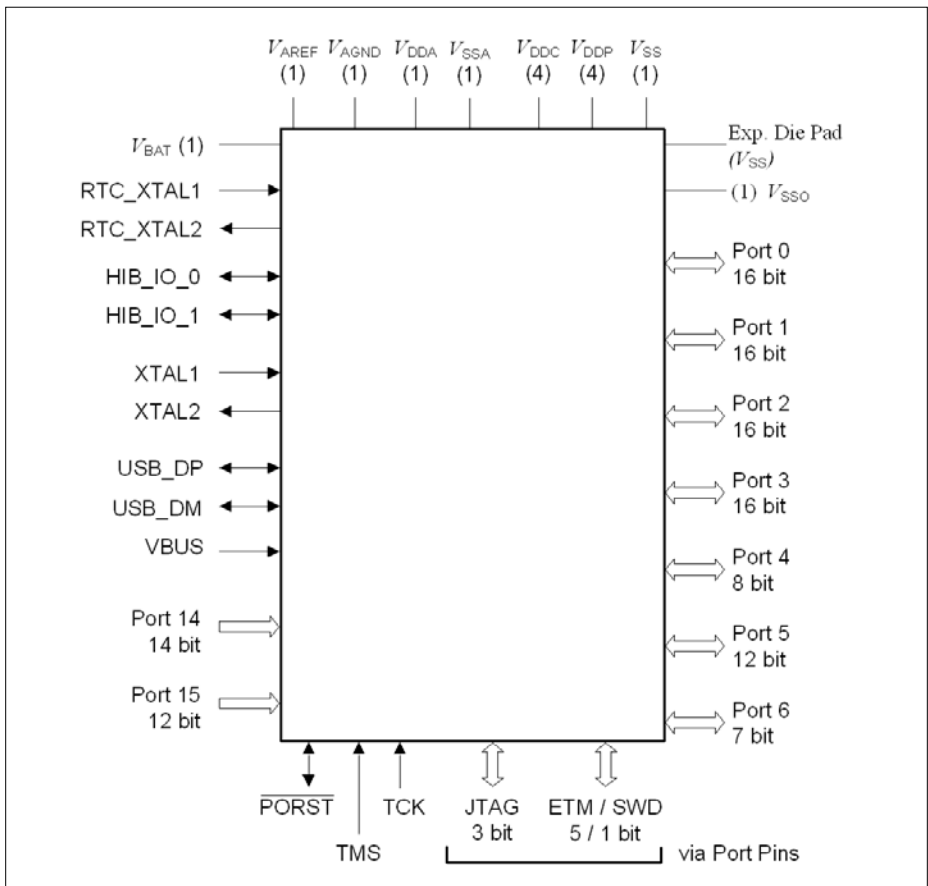

Figure 2 XMC4[78]00 Logic Symbol PG-LQFP-144

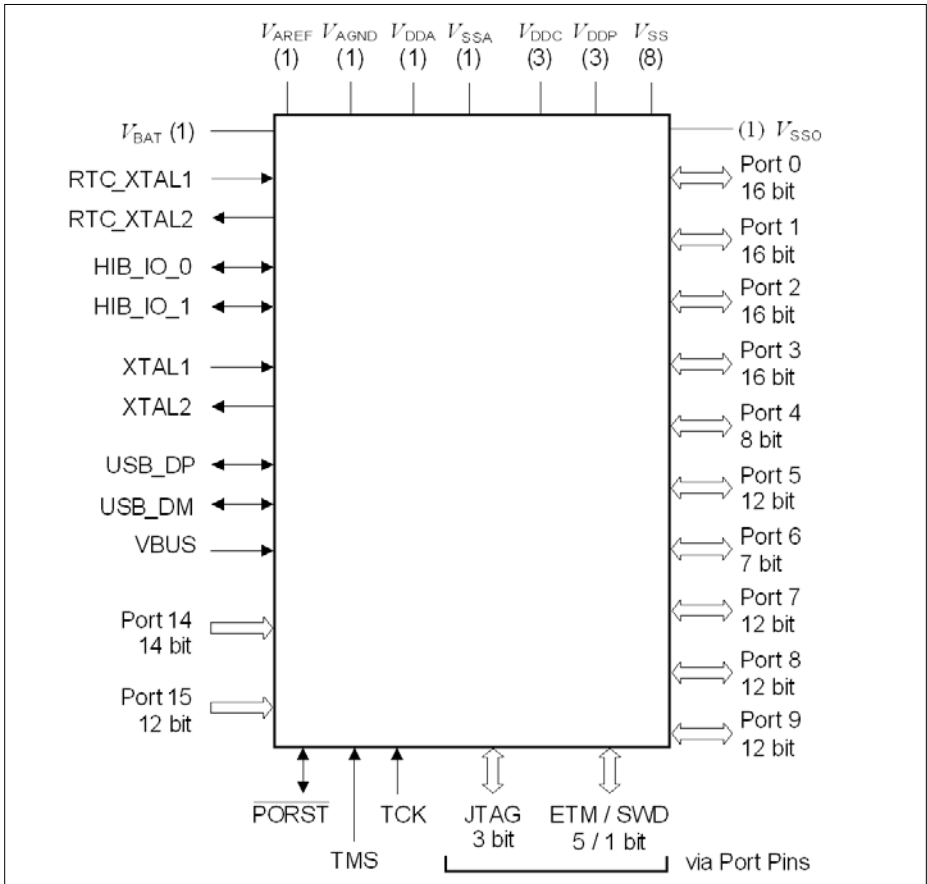

Figure 3 XMC4[78]00 Logic Symbol PG-LFBGA-196

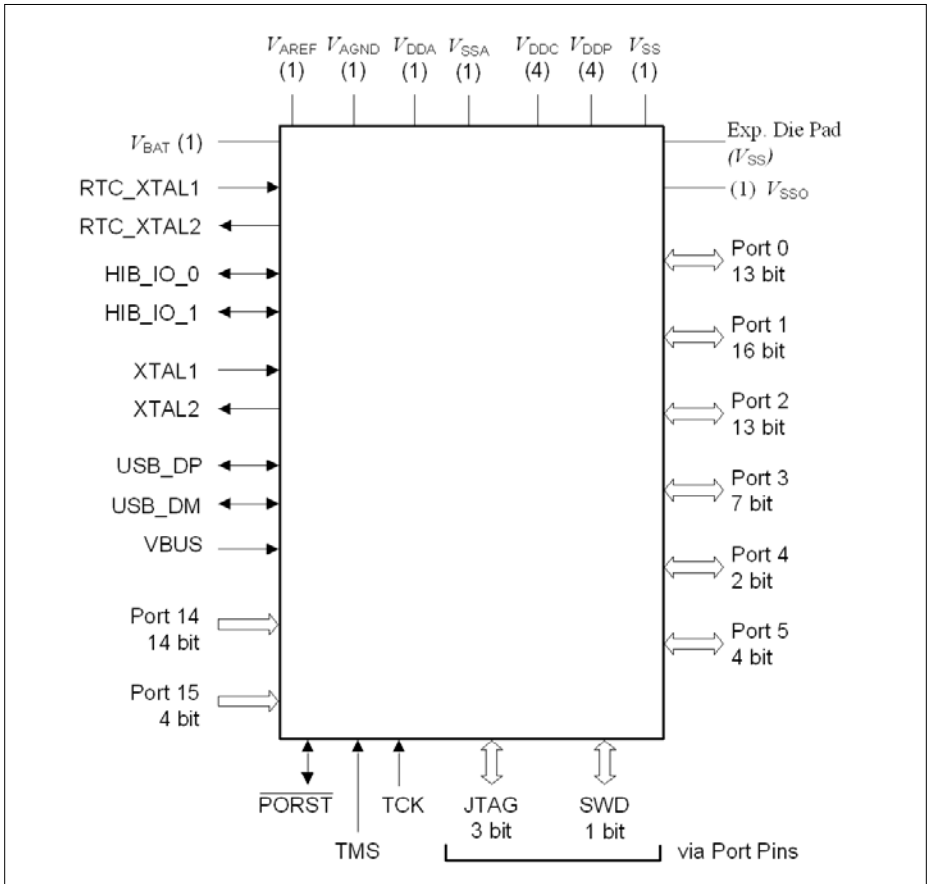

Figure 4 XMC4[78]00 Logic Symbol PG-LQFP-100

2.2 Pin Configuration and Definition

The following figures summarize all pins, showing their locations on the four sides of the different packages.

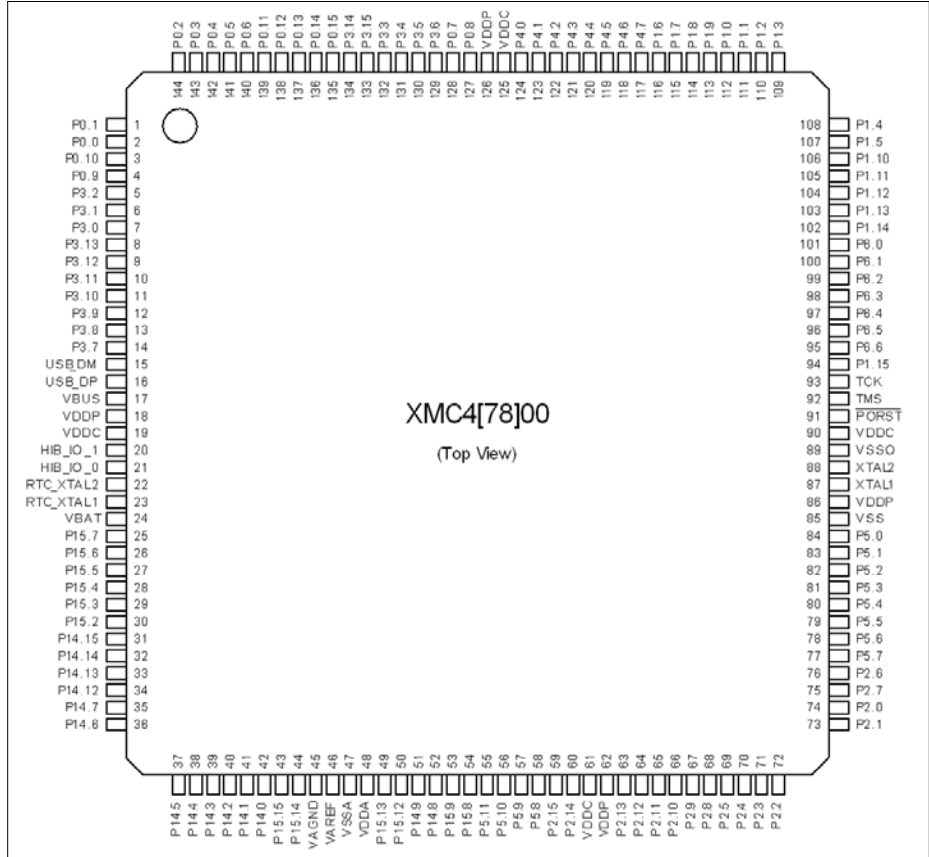

Figure 5 XMC4[78]00 PG-LQFP-144 Pin Configuration (top view)

General Device Information

	1	2	3	4	5	6	7	8	9	10	11	12	13	14	
A	VSS	P8.6	P8.8	P8.10	P8.9	P8.11	P8.1	P9.8	P9.7	P9.9	P9.5	P9.4	n.c.	VSS	A
B	n.c.	P8.3	P8.2	P8.7	P8.5	P8.4	P8.0	P9.10	P9.11	n.c.	P9.6	n.c.	VSS	n.c.	B
C	VSS	VDDC	P0.2	P0.3	P0.5	P0.6	P3.6	P0.8	P4.1	P1.8	VDDP	VSS	n.c.	n.c.	C
D	VDDP	P3.1	P3.2	P0.10	P0.4	P3.5	P0.7	P4.0	P1.6	P1.7	P1.9	VDDC	P9.3	P9.2	D
E	P3.0	P3.13	P0.1	P0.0	P0.13	P0.15	P4.4	P4.6	P4.7	P1.4	P1.2	P1.3	n.c.	P9.1	E
F	USB_D M	P3.12	P3.11	P0.9	P0.12	P3.14	P3.15	P4.5	P1.0	P1.5	P1.11	P1.10	P9.0	P7.11	F
G	USB_D P	VBUS	P3.8	P3.7	P0.11	P0.14	P3.4	P4.2	P1.1	P1.14	P1.12	P1.13	P7.9	P7.10	G
H	RTC_X TAL1	RTC_X TAL2	HIB_I O_1	HIB_I O_0	P3.9	P3.10	P3.3	P4.3	P6.1	P6.4	P6.5	P6.6	n.c.	P7.8	H
J	VBAT	P15.3	P15.5	P15.4	P15.6	P15.7	TMS	TCK	P6.3	P6.0	$\overline{\text{PORST}}$	P1.15	n.c.	P7.7	J
K	P15.2	P14.15	P14.14	P14.13	P5.10	P5.8	P5.2	P5.1	P5.0	P6.2	XTAL1	XTAL2	n.c.	P7.6	K
L	P14.12	P14.7	P14.6	P14.3	P5.11	P2.15	P5.7	P5.5	P2.6	P5.3	P2.0	VSSO	P7.0	P7.5	L
M	P14.4	P14.5	P14.2	P15.15	P15.12	P5.9	P2.14	P5.6	P2.7	P5.4	P2.2	P2.1	P7.1	P7.3	M
N	VDDA	P14.1	P14.0	P15.14	P14.9	P15.9	P2.12	P2.10	P2.8	P2.4	P2.3	VDDP	P7.2	P7.4	N
P	VSSA	VAGND	VAREF	P15.13	P14.8	P15.8	P2.13	P2.11	P2.9	P2.5	VDDC	VSS	n.c.	VSS	P
	1	2	3	4	5	6	7	8	9	10	11	12	13	14	

XMC4[78]00 - (top view)

Figure 6 XMC4[78]00 PG-LFBGA-196 Pin Configuration (top view)

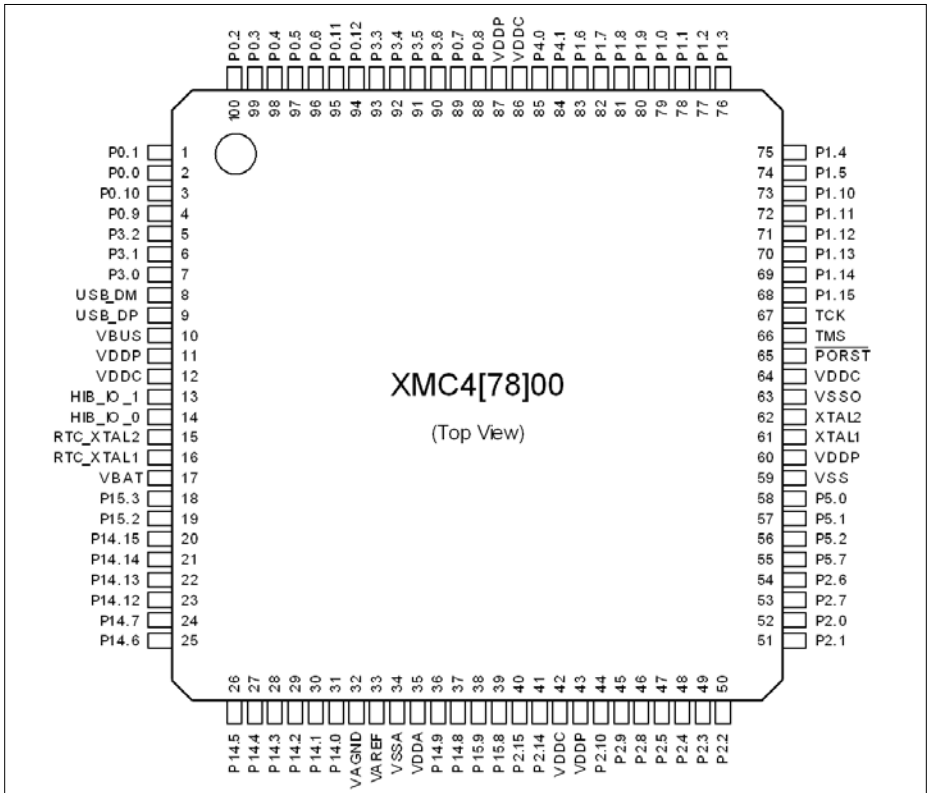

Figure 7 XMC4[78]00 PG-LQFP-100 Pin Configuration (top view)

2.2.1 Package Pin Summary

The following general scheme is used to describe each pin:

Table 9 Package Pin Mapping Description

Function	Package A	Package B	...	Pad Type	Notes
Name	N	Ax	...	A2	–

The table is sorted by the “Function” column, starting with the regular Port pins (Px.y), followed by the dedicated pins (i.e. PORST) and supply pins.

The following columns, titled with the supported package variants, lists the package pin number to which the respective function is mapped in that package.

The “Pad Type” indicates the employed pad type (A1, A1+, A2, special=special pad, In=input pad, AN/DIG_IN=analog and digital input, Power=power supply). Details about the pad properties are defined in the Electrical Parameters.

In the “Notes”, special information to the respective pin/function is given, i.e. deviations from the default configuration after reset. Per default the regular Port pins are configured as direct input with no internal pull device active.

Table 10 Package Pin Mapping

Function	LFBGA-196	LQFP-144	LQFP-100	Pad Type	Notes
P0.0	E4	2	2	A1+	–
P0.1	E3	1	1	A1+	–
P0.2	C3	144	100	A2	–
P0.3	C4	143	99	A2	–
P0.4	D5	142	98	A2	–
P0.5	C5	141	97	A2	–
P0.6	C6	140	96	A2	–
P0.7	D7	128	89	A2	After a system reset, via HWSEL this pin selects the DB.TDI function.
P0.8	C8	127	88	A2	After a system reset, via HWSEL this pin selects the DB.TRST function, with a weak pull-down active.
P0.9	F4	4	4	A2	–

General Device Information
Table 10 Package Pin Mapping (cont'd)

Function	LFBGA-196	LQFP-144	LQFP-100	Pad Type	Notes
P0.10	D4	3	3	A1+	–
P0.11	G5	139	95	A1+	–
P0.12	F5	138	94	A1+	–
P0.13	E5	137	–	A1+	–
P0.14	G6	136	–	A1+	–
P0.15	E6	135	–	A1+	–
P1.0	F9	112	79	A1+	–
P1.1	G9	111	78	A1+	–
P1.2	E11	110	77	A2	–
P1.3	E12	109	76	A2	–
P1.4	E10	108	75	A1+	–
P1.5	F10	107	74	A1+	–
P1.6	D9	116	83	A2	–
P1.7	D10	115	82	A2	–
P1.8	C10	114	81	A2	–
P1.9	D11	113	80	A2	–
P1.10	F12	106	73	A1+	–
P1.11	F11	105	72	A1+	–
P1.12	G11	104	71	A2	–
P1.13	G12	103	70	A2	–
P1.14	G10	102	69	A2	–
P1.15	J12	94	68	A2	–
P2.0	L11	74	52	A2	–
P2.1	M12	73	51	A2	After a system reset, via HWSEL this pin selects the DB.TDO function.
P2.2	M11	72	50	A2	–
P2.3	N11	71	49	A2	–
P2.4	N10	70	48	A2	–
P2.5	P10	69	47	A2	–
P2.6	L9	76	54	A1+	–

General Device Information

Table 10 Package Pin Mapping (cont'd)

Function	LFBGA-196	LQFP-144	LQFP-100	Pad Type	Notes
P2.7	M9	75	53	A1+	–
P2.8	N9	68	46	A2	–
P2.9	P9	67	45	A2	–
P2.10	N8	66	44	A2	–
P2.11	P8	65	-	A2	–
P2.12	N7	64	-	A2	–
P2.13	P7	63	-	A2	–
P2.14	M7	60	41	A2	–
P2.15	L6	59	40	A2	–
P3.0	E1	7	7	A2	–
P3.1	D2	6	6	A2	–
P3.2	D3	5	5	A2	–
P3.3	H7	132	93	A1+	–
P3.4	G7	131	92	A1+	–
P3.5	D6	130	91	A2	–
P3.6	C7	129	90	A2	–
P3.7	G4	14	–	A1+	–
P3.8	G3	13	–	A1+	–
P3.9	H5	12	–	A1+	–
P3.10	H6	11	–	A1+	–
P3.11	F3	10	–	A1+	–
P3.12	F2	9	–	A2	–
P3.13	E2	8	–	A2	–
P3.14	F6	134	–	A1+	–
P3.15	F7	133	–	A1+	–
P4.0	D8	124	85	A2	–
P4.1	C9	123	84	A2	–
P4.2	G8	122	–	A1+	–
P4.3	H8	121	–	A1+	–
P4.4	E7	120	–	A1+	–

General Device Information

Table 10 Package Pin Mapping (cont'd)

Function	LFBGA-196	LQFP-144	LQFP-100	Pad Type	Notes
P4.5	F8	119	–	A1+	–
P4.6	E8	118	–	A1+	–
P4.7	E9	117	–	A1+	–
P5.0	K9	84	58	A1+	–
P5.1	K8	83	57	A1+	–
P5.2	K7	82	56	A1+	–
P5.3	L10	81	–	A2	–
P5.4	M10	80	–	A2	–
P5.5	L8	79	–	A2	–
P5.6	M8	78	–	A2	–
P5.7	L7	77	55	A1+	–
P5.8	K6	58	–	A2	–
P5.9	M6	57	–	A2	–
P5.10	K5	56	–	A1+	–
P5.11	L5	55	–	A1+	–
P6.0	J10	101	–	A2	–
P6.1	H9	100	–	A2	–
P6.2	K10	99	–	A2	–
P6.3	J9	98	–	A1+	–
P6.4	H10	97	–	A2	–
P6.5	H11	96	–	A2	–
P6.6	H12	95	–	A2	–
P7.0	L13	–	–	A2	–
P7.1	M13	–	–	A2	–
P7.2	N13	–	–	A2	–
P7.3	M14	–	–	A2	–
P7.4	N14	–	–	A1+	–
P7.5	L14	–	–	A1+	–
P7.6	K14	–	–	A1+	–
P7.7	J14	–	–	A1+	–

General Device Information

Table 10 Package Pin Mapping (cont'd)

Function	LFBGA-196	LQFP-144	LQFP-100	Pad Type	Notes
P7.8	H14	–	–	A2	–
P7.9	G13	–	–	A1+	–
P7.10	G14	–	–	A1+	–
P7.11	F14	–	–	A1+	–
P8.0	B7	–	–	A2	–
P8.1	A7	–	–	A2	–
P8.2	B3	–	–	A2	–
P8.3	B2	–	–	A2	–
P8.4	B6	–	–	A1+	–
P8.5	B5	–	–	A1+	–
P8.6	A2	–	–	A1+	–
P8.7	B4	–	–	A1+	–
P8.8	A3	–	–	A2	–
P8.9	A5	–	–	A1+	–
P8.10	A4	–	–	A1+	–
P8.11	A6	–	–	A1+	–
P9.0	F13	–	–	A2	–
P9.1	E14	–	–	A2	–
P9.2	D14	–	–	A1+	–
P9.3	D13	–	–	A2	–
P9.4	A12	–	–	A1+	–
P9.5	A11	–	–	A1+	–
P9.6	B11	–	–	A1+	–
P9.7	A9	–	–	A1+	–
P9.8	A8	–	–	A1+	–
P9.9	A10	–	–	A1+	–
P9.10	B8	–	–	A1+	–
P9.11	B9	–	–	A1+	–
P14.0	N3	42	31	AN/DIG_IN	–
P14.1	N2	41	30	AN/DIG_IN	–

General Device Information

Table 10 Package Pin Mapping (cont'd)

Function	LFBGA-196	LQFP-144	LQFP-100	Pad Type	Notes
P14.2	M3	40	29	AN/DIG_IN	–
P14.3	L4	39	28	AN/DIG_IN	–
P14.4	M1	38	27	AN/DIG_IN	–
P14.5	M2	37	26	AN/DIG_IN	–
P14.6	L3	36	25	AN/DIG_IN	–
P14.7	L2	35	24	AN/DIG_IN	–
P14.8	P5	52	37	AN/DAC/DI G_IN	–
P14.9	N5	51	36	AN/DAC/DI G_IN	–
P14.12	L1	34	23	AN/DIG_IN	–
P14.13	K4	33	22	AN/DIG_IN	–
P14.14	K3	32	21	AN/DIG_IN	–
P14.15	K2	31	20	AN/DIG_IN	–
P15.2	K1	30	19	AN/DIG_IN	–
P15.3	J2	29	18	AN/DIG_IN	–
P15.4	J4	28	–	AN/DIG_IN	–
P15.5	J3	27	–	AN/DIG_IN	–
P15.6	J5	26	–	AN/DIG_IN	–
P15.7	J6	25	–	AN/DIG_IN	–
P15.8	P6	54	39	AN/DIG_IN	–
P15.9	N6	53	38	AN/DIG_IN	–
P15.12	M5	50	–	AN/DIG_IN	–
P15.13	P4	49	–	AN/DIG_IN	–
P15.14	N4	44	–	AN/DIG_IN	–
P15.15	M4	43	–	AN/DIG_IN	–
USB_DP	G1	16	9	special	–
USB_DM	F1	15	8	special	–

General Device Information
Table 10 Package Pin Mapping (cont'd)

Function	LFBGA-196	LQFP-144	LQFP-100	Pad Type	Notes
HIB_IO_0	H4	21	14	A1 special	At the first power-up and with every reset of the hibernate domain this pin is configured as open-drain output and drives "0". As output the medium driver mode is active.
HIB_IO_1	H3	20	13	A1 special	At the first power-up and with every reset of the hibernate domain this pin is configured as input with no pull device active. As output the medium driver mode is active.
TCK	J8	93	67	A1	Weak pull-down active.
TMS	J7	92	66	A1+	Weak pull-up active. As output the strong-soft driver mode is active.
$\overline{\text{PORST}}$	J11	91	65	special	Weak pull-up permanently active, strong pull-down controlled by EVR.
XTAL1	K11	87	61	clock_IN	–
XTAL2	K12	88	62	clock_O	–
RTC_XTAL1	H1	23	16	clock_IN	–
RTC_XTAL2	H2	22	15	clock_O	–
VBAT	J1	24	17	Power	When VDDP is supplied VBAT has to be supplied as well.
VBUS	G2	17	10	special	–
VAREF	P3	46	33	AN_Ref	–
VAGND	P2	45	32	AN_Ref	–
VDDA	N1	48	35	AN_Power	–
VSSA	P1	47	34	AN_Power	–
VDDC	–	19	12	Power	–
VDDC	–	61	42	Power	–
VDDC	–	90	64	Power	–

General Device Information

Table 10 Package Pin Mapping (cont'd)

Function	LFBGA-196	LQFP-144	LQFP-100	Pad Type	Notes
VDDC	–	125	86	Power	–
VDDC	C2	–	–	Power	–
VDDC	D12	–	–	Power	–
VDDC	P11	–	–	Power	–
VDDP	–	18	11	Power	–
VDDP	–	62	43	Power	–
VDDP	–	86	60	Power	–
VDDP	–	126	87	Power	–
VDDP	C11	–	–	Power	–
VDDP	D1	–	–	Power	–
VDDP	N12	–	–	Power	–
VSS	–	85	59	Power	–
VSS	A1	–	–	Power	–
VSS	A14	–	–	Power	–
VSS	B13	–	–	Power	–
VSS	C1	–	–	Power	–
VSS	C12	–	–	Power	–
VSS	P12	–	–	Power	–
VSS	P14	–	–	Power	–
VSSO	L12	89	63	Power	–
VSS	–	Exp. Pad	Exp. Pad	Power	<p>Exposed Die Pad The exposed die pad is connected internally to VSS. For proper operation, it is mandatory to connect the exposed pad directly to the common ground on the board. For thermal aspects, please refer to the Data Sheet. Board layout examples are given in an application note.</p>
n.c.	A13	–	–	Power	–

General Device Information

Table 10 Package Pin Mapping (cont'd)

Function	LFBGA-196	LQFP-144	LQFP-100	Pad Type	Notes
n.c.	B1	–	–	Power	–
n.c.	B10	–	–	Power	–
n.c.	B12	–	–	Power	–
n.c.	B14	–	–	Power	–
n.c.	C13	–	–	Power	–
n.c.	C14	–	–	Power	–
n.c.	E13	–	–	Power	–
n.c.	H13	–	–	Power	–
n.c.	J13	–	–	Power	–
n.c.	K13	–	–	Power	–
n.c.	P13	–	–	Power	–

2.2.2 Port I/O Functions

The following general scheme is used to describe each Port pin:

Table 11 Port I/O Function Description

Function	Outputs			Inputs		
	ALT1	ALTn	HWO0	HWI0	Input	Input
P0.0		MODA.OUT	MODB.OUT	MODB.INA	MODC.INA	
Pn.y	MODA.OUT				MODA.INA	MODC.INB

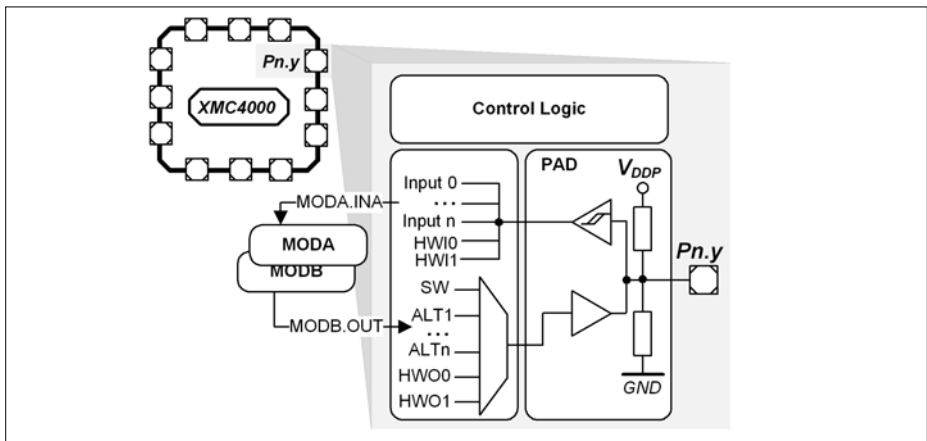

Figure 8 Simplified Port Structure

Pn.y is the port pin name, defining the control and data bits/registers associated with it. As GPIO, the port is under software control. Its input value is read via Pn_IN.y, Pn_OUT defines the output value.

Up to four alternate output functions (ALT1/2/3/4) can be mapped to a single port pin, selected by Pn_IOCR.PC. The output value is directly driven by the respective module, with the pin characteristics controlled by the port registers (within the limits of the connected pad).

The port pin input can be connected to multiple peripherals. Most peripherals have an input multiplexer to select between different possible input sources.

The input path is also active while the pin is configured as output. This allows to feedback an output to on-chip resources without wasting an additional external pin.

By Pn_HWSEL it is possible to select between different hardware “masters” (HWO0/HWI0). The selected peripheral can take control of the pin(s). Hardware control overrules settings in the respective port pin registers.

2.2.2.1 Port I/O Function Table

Table 12 Port I/O Functions

Function	Outputs					Inputs									
	ALT1	ALT2	ALT3	ALT4	HWC0	HWC1	HWC2	HWC3	HWC4	HWC5	HWC6	HWC7	HWC8	HWC9	HWC10
P0.0	ECAT0. PHY_RSTP	CAN. MC_TXD	CC880. OUT2	LEDTS0. COL2						U/C1. DVID	ETH0. CLK_RMIB	ERL0. 0B0			ETH0. CIRRXB
P0.1	USB. DRIVE/BSUS	U/C1. DOU70	CC880. OUT11	LEDTS0. COL3						ETH0. CRS_DVB		ERL0. 0A0			ECAT0. PI_RX_CLKA
P0.2	ECAT0. PI_TXD03	U/C1. SELO1	CC880. OUT10		U/C0. DOU73	ERU1. AD9	U/C0. HWNS	ERU1. DO0	ERU1. RXD0B			ERU1. 3B3			
P0.3	ECAT0. PI_TXD03	U/C0. DOU70	CC880. OUT20		U/C0. DOU72	ERU1. AD9	U/C0. HWNS	ERU1. DO1	ERU1. RXD1B			ERU1. 3B0			
P0.4	ETH0. TX_EN	U/C0. DOU70	CC880. OUT10		U/C0. DOU71	ERU1. AD2	U/C0. HWNS	ERU1. DO2	U/C0. D0XA	U/C0. D0XA	ERL0. 2B5				ECAT0. PI_TXD03A
P0.5	ETH0. TXD0	U/C0. DOU70	CC880. OUT00		U/C0. DOU70	ERU1. AD3	U/C0. HWNS	ERU1. DO3	U/C0. D0XB	U/C0. D0XB		ERU1. 5A0			ECAT0. PI_TXD03A
P0.6	ETH0. TXD1	U/C0. SELO0	CC880. OUT30		ERU1. AD7	ERU1. AD7			U/C0. D0XA	U/C0. D0XA	ERL0. 3B2		CC180. N2B		ECAT0. PI_TXD03A
P0.7	WWD0T. SERVICE_OUT	U/C0. SELO0	ECAT0. LED_FRR		ERU1. AD6	ERU1. D6	U/C0. D0XA	ERU1. DO6	U/C0. D0XB	U/C0. D0XB	ERL0. 2B1		CC180. N2A		CC880. IN3A
P0.8	SQU. EXCLK	U/C0. SCK/OUT	ECAT0. LED_RUN		ERU1. AD7	ERU1. D7	U/C0. D0XA	ERU1. DO7	U/C0. D0XB	U/C0. D0XB	ERL0. 2A1		CC180. N1B		
P0.9	ETH0. MDC	U/C1. SELO0	CC880. OUT2	LEDTS0. COL1	ERU1. ES1	ERU1. ES1	U/C1. D0XA	ERU1. DO1	U/C1. D0XA	U/C1. D0XA	ERL0. 5B1				ECAT0. PI_TX_DVA
P0.10	ETH0. MDC	U/C1. SCK/OUT	CC880. OUT2	LEDTS0. COL1	ERU1. ES1	ERU1. ES1	U/C1. D0XA	ERU1. DO1	U/C1. D0XA	U/C1. D0XA	ERL0. 5A0				ECAT0. PI_TX_CLKA
P0.11	ECAT0. PI_LINK_ACT	U/C0. SCK/OUT	CC880. OUT31		ERU1. BREQ	ERU1. BREQ	ETH0. RXERB	U/C0. D0XA	U/C0. D0XA	U/C0. D0XA	ERL0. 3A2				ECAT0. PI_TXD03A
P0.12	ECAT0. PD_TXD03	U/C1. SELO0	CC880. OUT3		ERU1. HELD	ERU1. HELD	U/C1. D0XA	ERU1. DO3	U/C1. D0XB	U/C1. D0XB	ERL0. 2B2				ECAT0. PI_TXD03A
P0.13		U/C1. SCK/OUT	CC880. OUT2		ERU1. HELD	ERU1. HELD	U/C1. D0XA	ERU1. DO2	U/C1. D0XB	U/C1. D0XB	ERL0. 2A2				
P0.14		U/C0. SELO0	CC880. OUT1		U/C1. DOU73	U/C1. DOU73	U/C1. HWNS				CC180. N2C				
P0.15		U/C0. SELO0	CC880. OUT0		U/C1. DOU72	U/C1. DOU72	U/C1. HWNS				CC180. N2C				
P1.0	DSD. CP/RMIN	U/C0. SELO0	CC880. OUT3	ERU1. PD/OUT3	U/C0. DOU73	U/C0. DOU73	U/C0. HWNS	U/C0. D0XA	U/C0. D0XA	U/C0. D0XA	ERL0. 3B0		CC180. N3A		ECAT0. PI_TX_CLKA
P1.1	DSD. CP/WMP	U/C0. SCK/OUT	CC880. OUT2	ERU1. PD/OUT2	SDMMC. SDWC	SDMMC. SDWC	U/C0. D0XA	U/C0. D0XA	U/C0. D0XA	U/C0. D0XA	ERL0. 3A0		CC180. N2A		ECAT0. PI_TX_CLKA
P1.2	ECAT0. PD_TXD03	U/C0. SELO0	CC880. OUT1	ERU1. PD/OUT1	U/C0. DOU73	ERU1. AD14	U/C0. HWNS	ERU1. DO14	U/C0. D0XA	U/C0. D0XA	ERL0. 3A0		CC180. N2A		ECAT0. PI_TX_CLKA
P1.3	ECAT0. PD_TX_ENA	U/C0. MCK/OUT	CC880. OUT0	ERU1. PD/OUT0	U/C0. DOU72	ERU1. AD15	U/C0. HWNS	ERU1. DO15	U/C0. D0XA	U/C0. D0XA	ERL0. 2A0		CC180. N2A		
P1.4	WWD0T. SERVICE_OUT	CAN. PL_TXD	CC880. OUT33	CC881. OUTB3	U/C0. DOU71	U/C0. DOU71	U/C0. HWNS	U/C0. D0XA	U/C0. D0XB	CAN. PL_TXD0D	ERL0. 2B5		CC180. N2C		ECAT0. PI_TXD03A

Table 12 Port I/O Functions (cont'd)

Function	Outputs					Inputs							
	AL71	AL72	AL73	AL74	HW00	HW01	HW10	HW11	Input	Input	Input	Input	Input
P1.5	CAN_NL_TXD0	UC00_DOUT0	CC180_OUT23	CC181_OUT10	UC00_DOUT0	UC00_HWIN0	UC00_DIN0A	CAN_NL_RXD0A	CC141_INTIC	ERU0_ZAD	ERU1_GAO	CC141_INTIC	ECAT0_PU_RXD0A
P1.6	SC170_PU_TXD0	UC00_SCKOUT			SC170_SCKOUT	ERU1_AD10	UC00_DIN0A						
P1.7	ECAT0_PU_TXD0	UC00_SCKOUT	DSD_MCLK2	U1C1_SEO2	SC170_SCKOUT	ERU1_AD11	UC00_DIN0A	DSD_MCLK2				DSD_MCLK2	
P1.8	ECAT0_PU_TXD2	UC00_SELO1	MCK1K1	U1C1_SCLKOUT	SC170_SCKOUT	ERU1_AD12	CAN_NL_RXD0A	DSD_MCK1K1A				DSD_MCK1K2D	DSD_MCK1K0D
P1.9	UC00_SCKOUT	CAN_NL_TXD0	MCK1K0	U1C1_SCKOUT	SC170_SCKOUT	ERU1_AD13	UC00_DIN0A	DSD_MCK1K0A				DSD_MCK1K2C	DSD_MCK1K3C
P1.10	ETH0_MDC	UC00_SCKOUT	CC181_OUT21	ECAT0_LED_ERR	SC170_SCKOUT	ERU1_AD14	UC00_DIN0A	DSD_MCK1K0A				CC141_INTIC	ECAT0_PU_RX_DVA
P1.11	ECAT0_LED_STATE_RU_N	UC00_SELO0	CC181_OUT11	ECAT0_LED_ERR	SC170_SCKOUT	ERU1_AD15	UC00_DIN0A	DSD_MCK1K0A				CC141_INTIC	ECAT0_PU_RXD0A
P1.12	ETH0_TX_EN	CAN_NL_TXD0	CC181_OUT01	ECAT0_LED_ERR	SC170_SCKOUT	ERU1_AD16	UC00_DIN0A	DSD_MCK1K0A				CC141_INTIC	ECAT0_PU_RXD0A
P1.13	ETH0_TXD3	UC01_SELO3	CC181_OUT20	ECAT0_LED_ERR	SC170_SCKOUT	ERU1_AD17	CAN_NL_RXD0C						
P1.14	ETH0_TXD1	UC01_SELO2	CC181_OUT10	ECAT0_LED_ERR	SC170_SCKOUT	ERU1_AD18	UC00_DIN0A						
P1.15	SCU_EXTCLK	DSD_MCLK2	CC181_OUT00	ECAT0_LED_ERR	SC170_SCKOUT	ERU1_AD19	UC00_DIN0A	DSD_MCLK2B					ECAT0_PU_LIN0B
P2.0	CAN_NL_TXD0	CC181_OUT21	DSD_CGPWMN	ETH0_MDO	ETH0_MDO	ERU1_AD20	ETH0_MDO			ERU0_0B3		CC140_INTIC	
P2.1	CAN_NL_TXD0	CC181_OUT11	DSD_CGPWMP	ETH0_MDO	ETH0_MDO	ERU1_AD21	ETH0_MDO					CC140_INTIC	ETH0_CHEXA
P2.2	VADC_EMUX00	CC181_OUT03	CC141_OUT3	ETH0_MDO	ETH0_MDO	ERU1_AD22	ETH0_MDO					CC141_INTIC	
P2.3	VADC_EMUX01	CC141_OUT2	CC141_OUT2	ETH0_MDO	ETH0_MDO	ERU1_AD23	ETH0_MDO					CC141_INTIC	
P2.4	VADC_EMUX02	CC141_OUT1	CC141_OUT1	ETH0_MDO	ETH0_MDO	ERU1_AD24	ETH0_MDO					CC141_INTIC	
P2.5	ETH0_TX_EN	UC00_SELO0	CC141_OUT0	ETH0_MDO	ETH0_MDO	ERU1_AD25	ETH0_MDO					CC141_INTIC	ETH0_CRS_DVA
P2.6	UC00_SELO4	ERU1_PDOU03	CC180_OUT13	ETH0_MDO	ETH0_MDO	ERU1_AD26	ETH0_MDO					CC140_INTIC	ETH0_CRS_DVA
P2.7	ETH0_MDC	CAN_NL_TXD0	CC180_OUT03	ETH0_MDO	ETH0_MDO	ERU1_AD27	ETH0_MDO					CC140_INTIC	
P2.8	ETH0_TXD9	ERU1_PDOU01	CC180_OUT23	ETH0_MDO	ETH0_MDO	ERU1_AD28	ETH0_MDO					CC140_INTIC	CC140_IN0B
P2.9	ETH0_TXD1	ERU1_PDOU02	CC180_OUT22	ETH0_MDO	ETH0_MDO	ERU1_AD29	ETH0_MDO					CC140_INTIC	CC140_IN0B
P2.10	VADC_EMUX10	ERU1_PDOU00	CC180_OUT21	ETH0_MDO	ETH0_MDO	ERU1_AD30	ETH0_MDO					CC140_INTIC	CC140_IN0B
P2.11	ETH0_TXD8	ERU1_PDOU00	CC180_OUT22	ETH0_MDO	ETH0_MDO	ERU1_AD31	ETH0_MDO					CC140_INTIC	CC140_IN0B

Table 12 Port I/O Functions (cont'd)

Function	Outputs					Inputs						
	ALT1	ALT2	ALT3	ALT4	HW00	HW01	HW10	HW11	Input	Input	Input	Input
P2.12	ETH0_TMD2	ECAT0_P1_TXD1	COH41_OUT33	ETH0_TXD0	DB_ETM_TRACEDA_TA1	ERU_AD30	ERU_D30	ERU_TA1	U/C0	COH43_IN3C	COH43_IN3C	COH43_IN3C
P2.13	ETH0_TMD3	ECAT0_P1_TXD2	COH41_OUT34	ETH0_TXD1	DB_ETM_TRACEDA_TA0	ERU_AD31	ERU_D31	ERU_TA0	U/C0	COH43_IN3C	COH43_IN3C	COH43_IN3C
P2.14	VADC_EMUJ11	U/C0_DOUT0	COH80_OUT21	CAN_ML_TXD	DB_ETM_TRACECLK_B02	ERIT_B02			U/C0_DX0D	COH43_IN3B	COH43_IN3B	COH43_IN3B
P2.15	VADC_EMUJ12	ECAT0_P1_TXD3	COH80_OUT11	LEDTS0_LINE9	LEDTS0_EXTENDED06	ERIT_B01	LEDTS0_TSINA	ETH0_COA	U/C0_DX0C	COH42_IN3B	COH42_IN3B	COH42_IN3B
P3.0	U/C1_SELO0	U/C1_SCLKOUT	COH42_OUT0	ECAT0_P1_TX_BNA	ERIT_B03	ERIT_B03		U/C1_DXB	U/C1_DXB	COH80_IN3C	COH80_IN3C	COH80_IN3C
P3.1	U/C1_SELO1	U/C1_SELO0	ECAT0_P1_TXD0	ERIT_B02	ERIT_B02	ERIT_B02		U/C1_DXB	ERU0_B01	COH80_IN3C	COH80_IN3C	COH80_IN3C
P3.2	USB_DRIVE/VSUS	CAN_ML_TXD	ECAT0_P1_TXD1	LEDTS0_COA	ERIT_C50	ERIT_C50		U/C1_DXB	ERU0_GA1	COH80_IN3C	COH80_IN3C	COH80_IN3C
P3.3	U/C1_SELO1	U/C1_SELO1	COH42_OUT3	ECAT0_MCLK	SDMMC_LED	SDMMC_LED		ERIT_WAIT	DSO_DSO	COH42_IN3A	COH42_IN3A	COH42_IN3A
P3.4	U/C1_MCLKOUT	U/C1_SELO2	COH42_OUT2	DSO_MCLK3	SDMMC_BIS_POWER	SDMMC_BIS_POWER		ERIT_HOLD	DSO_MCLK3B	COH42_IN3A	COH42_IN3A	COH42_IN3A
P3.5	U/C1_DOUT0	U/C1_SELO0	COH42_OUT1	U/C1_DOUT0	SDMMC_CMD_OUT	ERU_A54	SDMMC_CMD_IN	ERU_D4	U/C1_DXB	COH42_IN3A	COH42_IN3A	COH42_IN3A
P3.6	U/C1_SCLKOUT	U/C1_SELO1	COH42_OUT0	U/C1_SCLKOUT	SDMMC_CS_OUT	ERU_A55	SDMMC_CS_IN	ERU_D5	U/C1_DXB	COH42_IN3A	COH42_IN3A	COH42_IN3A
P3.7	ECAT0_SYNC0	CAN_ML_TXD	COH41_OUT3	LEDTS0_LINE0	LEDTS0_LINE0				U/C0_DX0C			
P3.8	U/C0_DOUT0	U/C0_SELO0	COH41_OUT2	LEDTS0_LINE1	LEDTS0_LINE1				CAN_ML_RX0B	POSIF1_IN3B	POSIF1_IN3B	POSIF1_IN3B
P3.9	U/C0_SCLKOUT	CAN_ML_TXD	COH41_OUT1	LEDTS0_LINE2	LEDTS0_LINE2					POSIF1_IN3B	POSIF1_IN3B	POSIF1_IN3B
P3.10	U/C0_SELO0	CAN_ML_TXD	COH41_OUT0	LEDTS0_LINE3	LEDTS0_LINE3					POSIF1_IN3B	POSIF1_IN3B	POSIF1_IN3B
P3.11	U/C1_SELO0	U/C1_SELO0	COH42_OUT3	LEDTS0_LINE4	LEDTS0_LINE4				CAN_ML_RX0B	COH81_IN3C	COH81_IN3C	COH81_IN3C
P3.12	ECAT0_P1_LINKACT	U/C1_SELO1	COH42_OUT2	LEDTS0_LINES	LEDTS0_LINES				U/C1_DX0D	COH81_IN3C	COH81_IN3C	COH81_IN3C
P3.13	U/C1_SCLKOUT	U/C1_DOUT0	COH42_OUT1	LEDTS0_LINE6	LEDTS0_LINE6					COH80_IN3C	COH80_IN3C	COH80_IN3C
P3.14	U/C1_SELO0	U/C0_SELO0	COH42_OUT0	LEDTS0_LINE7	LEDTS0_LINE7				U/C1_DX0B	COH42_IN3C	COH42_IN3C	COH42_IN3C
P3.15	U/C1_DOUT0	U/C1_DOUT0	COH41_OUT0	LEDTS0_LINE8	LEDTS0_LINE8				U/C1_DXB	COH42_IN3C	COH42_IN3C	COH42_IN3C
P4.0	CAN_ML_TXD	ERU_PPK_CK25	ERU_MCLK1	U/C0_SCLKOUT	SDMMC_DATA_OUT	ERU_A59	SDMMC_DATA_IN	ERU_D8	U/C1_DXB	ERU_MCLK1B	U/C1_DX0C	ERU_PPK_ERRA
P4.1	U/C1_SELO0	U/C1_MCLKOUT	DSO_MCLK0	U/C1_SELO0	SDMMC_DATA_OUT	ERU_A59	SDMMC_DATA_IN	ERU_D9	DSO_MCLK0B	DSO_MCLK0B	U/C1_DXA	ECAT0_P1_LINKA
P4.2	U/C1_SELO1	U/C1_DOUT0	ECAT0_SCLKOUT	U/C1_SCLKOUT	MDIO		ECAT0_MDIO		U/C1_DXB	U/C1_DXA	U/C1_DXA	COH43_IN3C

Table 12 Port I/O Functions (cont'd)

Function	Outputs					Inputs										
	ALT1	ALT2	ALT3	ALT4	HW00	HW01	HW10	HW11	Input	Input	Input	Input	Input	Input	Input	Input
P4.3	UC01_SELO2	UC00_SELO6	CC043_OUT3	ECAT0_WCLK										CC043_IN3A		
P4.4		UC01_SELO4	CC043_OUT2	UC01_DOUT3			UC01_HW03							CC043_IN3A		
P4.5		UC00_SELO8	CC043_OUT1	UC01_DOUT2			UC01_HW02							CC043_IN3A		
P4.6		UC00_SELO2	CC043_OUT0	UC01_DOUT1			UC01_HW01	CAN_NZ_RX0D					UC01_DWE	CC043_IN3A		
P4.7	UC21_DOUT0	CAN_NZ_TX0		UC01_DOUT0			UC01_HW00	DX0C					UC01_DWE	CC043_IN3C		
P5.0	UC00_PSD_COPWMM	PSD_COPWMM	CC081_OUT3	ERU1_PROD0	UC00_DOUT0		UC00_HW00	DX0B	ETH0_RX0D0				UC00_DWD	CC081_IN3A		CC081_IN3A
P5.1	UC00_PSD_COPWMP	PSD_COPWMP	CC081_OUT2	ERU1_PROD1	UC00_DOUT1		UC00_HW01	DX0A	ETH0_RX0D1				UC00_DWD	CC081_IN3B		CC081_IN3B
P5.2	UC00_SCKOUT	ECAT0_PL_LINK_ACT	CC081_OUT1	ERU1_PROD2			UC00_HW02	DATA	ETH0_CARL_DVD				UC00_DWD	CC081_IN3B		ETH0_RX0VD
P5.3	UC00_SELO0		CC081_OUT0	ERU1_PROD3	ERU1_A20			DC0A	ETH0_RX0D0				UC00_DWD	CC081_IN3B		
P5.4	UC00_SELO1		CC081_OUT13	ERU1_A21	ERU1_A21			DC0A	ETH0_RX0D0				UC00_DWD	CC081_IN3B		ECAT0_PO_RX_CLKB
P5.5	UC00_SELO2		CC081_OUT12	ERU1_A22	ERU1_A22				ETH0_COLD				UC00_DWD	CC081_IN3B		ECAT0_PO_TX_CLKB
P5.6	UC00_SELO3		CC081_OUT103	ERU1_A23	ERU1_BFCLOD			ERU1_BFCLOI					UC00_DWD	CC081_IN3B		ECAT0_PO_RX_DVB
P5.7	ECAT0_ST0D9		CC081_OUT102	EDT00_G0SA	UC00_DOUT2		UC00_HW02						ECAT0_PL_RX0DB			
P5.8	ECAT0_PL_TX_ENA	UC00_SCKOUT	CC080_OUT01	CAN_ML_TX0	ERU1_SCKIAD	ERU1_CSZ		ETH0_RX0DA	UI00_DXB				ECAT0_PL_RX0DB			
P5.9	UC00_SELO0	UC00_SELO0	CC080_OUT020	ETH0_TX_EN	ERU1_BFCLOD	ERU1_CSZ		ETH0_RX0DA	UI00_DXB				ECAT0_PL_RX0DB			
P5.10	UC00_MCKOUT	UC00_MCKOUT	CC080_OUT10	LEDT00_LINE7	LEDT00_EXTENDED			ETH0_CLK_TXA	UI00_DXB				ECAT0_PL_RX0DB			
P5.11	UC00_SELO1	UC00_SELO1	CC080_OUT000	CAN_N5_TX0				ETH0_RX0SA	UI00_DXB				ECAT0_PL_RX0DB			
P6.0	ETH0_TAD0	UC01_SELO1	CC081_OUT031	ERU1_PHY_CLK25	ERU1_ETM_TRACECLK_A19											
P6.1	ETH0_TAD3	UC01_SELO0	CC081_OUT030	DB_ETM_TRACECLK_A17	ERU1_SCKIAD	ERU1_CSZ		ETH0_RX0DA	UI00_DXB				ECAT0_PL_RX0DB			
P6.2	ETH0_TAD9	UC01_SCKOUT	CC043_OUT15	DB_ETM_TRACECLK_A19	ERU1_SCKIAD	ERU1_CSZ		ETH0_RX0DA	UI00_DXB				ECAT0_PL_RX0DB			
P6.3			CC043_OUT12	DB_ETM_TRACECLK_A17	ERU1_SCKIAD	ERU1_CSZ		ETH0_RX0DA	UI00_DXB				ECAT0_PL_RX0DB			
P6.4		UC01_DOUT0	CC043_OUT11	ERU1_SCKIAD	ERU1_SCKIAD	ERU1_CSZ		ETH0_RX0DA	UI00_DXB				ECAT0_PL_RX0DB			
P6.5	CAN_N3_TX0	UC01_MCKOUT	CC043_OUT10	DB_ETM_TRACECLK_A19	ERU1_SCKIAD	ERU1_CSZ		ETH0_RX0DA	UI00_DXB				ECAT0_PL_RX0DB			ETH0_CURVD

Table 12 Port I/O Functions (cont'd)

Function	Outputs					Inputs							
	ALT1	ALT2	ALT3	ALT4	HW00	HW01	HW10	HW11	Input	Input	Input	Input	Input
P8.6	U0C0_DOUT0		RS0_MCLK3	ECAT0_P0_TX03	DB_ETM_TRACEDA_TAO	EBT_BE3			RS0_MCLK3A	ETH0_CLK_TXB		CAN_NS_RX0B	
P7.0		CAN_NS_TX0		ECAT0_P0_TX00	ERU_P0_TX00								
P7.1				ECAT0_P0_TX01	ERU_P0_TX01					CAN_NS_RX0C			
P7.2		CAN_NS_TX0		ECAT0_P0_TX02	ERU_P0_TX02								
P7.3				ECAT0_P0_TX03	ERU_P0_TX03					CAN_NS_RX0C			
P7.4			CCM42_OUT0						ECAT0_P0_RX0DC				
P7.5			CCM42_OUT1						ECAT0_P0_RX0DC				
P7.6			CCM42_OUT2						ECAT0_P0_RX0DC				
P7.7			CCM42_OUT3						ECAT0_P0_RX0DC				
P7.8		CAN_NS_TX0		ECAT0_P0_TX_ENA	DB_ETM_TRACCLK				ECAT0_P0_RX_ERRRC				
P7.9			CCM80_OUT2										
P7.10			CCM80_OUT3						ECAT0_P0_RX_CLKC				
P7.11			CCM80_OUT33						ECAT0_P0_RX_DVC				
P8.0				ECAT0_P1_TX00	ERU_ETM_TRACEDA_TAO					CAN_NS_RX0C			
P8.1				ECAT0_P1_TX01	ERU_ETM_TRACEDA_TAO					U0C0_D0XC			
P8.2				ECAT0_P1_TX02	ERU_ETM_TRACEDA_TAO								
P8.3				ECAT0_P1_TX03	DB_ETM_TRACEDA_TAO					U0C0_DX1C			
P8.4		U0C0_SEL0							ECAT0_P1_RX0DC				
P8.5		SCLKOUT							ECAT0_P1_RX0DC				
P8.6		U0C0_SEL0											
P8.7		U0C0_DOUT0							ECAT0_P1_RX0DC				
P8.8				ECAT0_P1_TX_ENA						U0C0_D0XE			

Table 12 Port I/O Functions (cont'd)

Function	Outputs					Inputs								
	ALT1	ALT2	ALT3	ALT4	HW00	HW01	HW10	HW11	Input	Input	Input	Input	Input	Input
P14.8					PAC_OUT_0				VADC_G1CH0	VADC_G1CH2	VADC_G1CH2	ETH0_RXD3C		
P14.9					PAC_OUT_1				VADC_G1CH1			ETH0_RXD3C		
P14.12									VADC_G1CH4					ECAT0_P1_RXD1B
P14.13									VADC_G1CH5					ECAT0_P1_RXD2B
P14.14									VADC_G1CH8				G1ORC6	ECAT0_P1_RXD3B
P14.15									VADC_G1CH7				G1ORC7	ECAT0_P1_RX_DVB
P15.2									VADC_G2CH2					ECAT0_P1_RX_ERRB
P15.3									VADC_G2CH3					ECAT0_P1_LW4B
P15.4									VADC_G2CH4					
P15.5									VADC_G2CH5					
P15.6									VADC_G2CH6					
P15.7									VADC_G2CH7					
P15.8										VADC_G2CH0	VADC_G2CH0	ETH0_G2_CMIIC		ETH0_G2ORC
P15.9										VADC_G2CH1	VADC_G2CH1	ETH0_ORG_DWC		ETH0_R0VDC
P15.12										VADC_G2CH4				
P15.13										VADC_G2CH5				
P15.14										VADC_G2CH6				
P15.15										VADC_G2CH7				
HB_IO_0	HBOUT													
HB_IO_1	HBOUT	WWDT_SERVICE_OUT												
USB_DP		USB_DP												
USB_DM		USB_DM												
TK		TK												
TMS		TMS												
PORTF		PORTF												

Table 12 Port I/O Functions (cont'd)

Function	Outputs						Inputs							
	ALT1	ALT2	ALT3	ALT4	HWO0	HWO1	HWI0	HWI1	Input	Input	Input	Input	Input	Input
XTAL1									MCC0 DX0F	MCC1 DX0F	UC00 DX0F	UC01 DX0F	UC02 DX0F	UC03 DX0F
XTAL2														
RTC_XTAL1											ERL00, IB1			
RTC_XTAL2														

2.3 Power Connection Scheme

Figure 9 shows a reference power connection scheme for the XMC4[78]00.

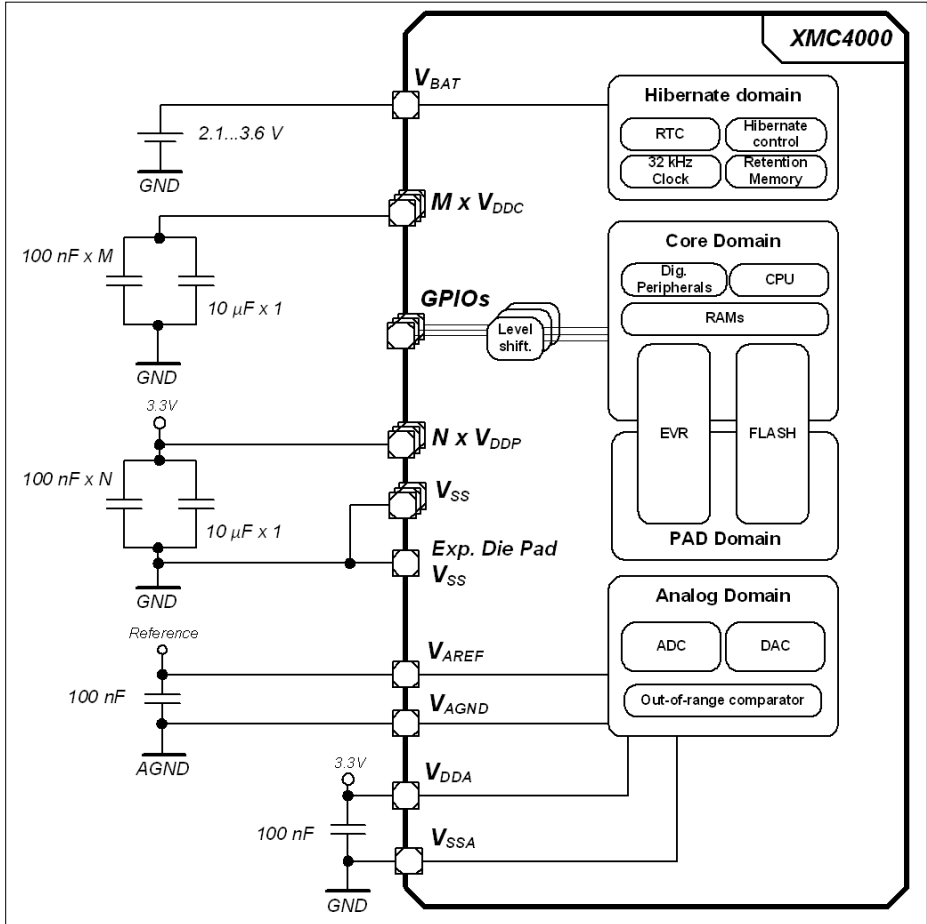

Figure 9 Power Connection Scheme

Every power supply pin needs to be connected. Different pins of the same supply need also to be externally connected. As example, all V_{DDP} pins must be connected externally to one V_{DDP} net. In this reference scheme one 100 nF capacitor is connected at each supply pin against V_{SS} . An additional $10\text{ }\mu\text{F}$ capacitor is connected to the V_{DDP} nets and an additional $10\text{ }\mu\text{F}$ capacitor to the V_{DDC} nets.

The XMC4[78]00 has a common ground concept, all V_{SS} , V_{SSA} and V_{SSO} pins share the same ground potential. In packages with an exposed die pad it must be connected to the common ground as well.

V_{AGND} is the low potential to the analog reference V_{AREF} . Depending on the application it can share the common ground or have a different potential. In devices with shared V_{DDA}/V_{AREF} and V_{SSA}/V_{AGND} pins the reference is tied to the supply. Some analog channels can optionally serve as “Alternate Reference”; further details on this operating mode are described in the Reference Manual.

When V_{DDP} is supplied, V_{BAT} must be supplied as well. If no other supply source (e.g. battery) is connected to V_{BAT} , the V_{BAT} pin can also be connected directly to V_{DDP} .

3 Electrical Parameters

Attention: All parameters in this chapter are preliminary target values and may change based on characterization results.

3.1 General Parameters

3.1.1 Parameter Interpretation

The parameters listed in this section partly represent the characteristics of the XMC4[78]00 and partly its requirements on the system. To aid interpreting the parameters easily when evaluating them for a design, they are marked with a two-letter abbreviation in column "Symbol":

- **CC**
Such parameters indicate **C**ontroller **C**haracteristics, which are a distinctive feature of the XMC4[78]00 and must be regarded for system design.
- **SR**
Such parameters indicate **S**ystem **R**equirements, which must be provided by the application system in which the XMC4[78]00 is designed in.

3.1.2 Absolute Maximum Ratings

Stresses above the values listed under “Absolute Maximum Ratings” may cause permanent damage to the device. This is a stress rating only and functional operation of the device at these or any other conditions above those indicated in the operational sections of this specification is not implied. Exposure to absolute maximum rating conditions may affect device reliability.

Table 13 Absolute Maximum Rating Parameters

Parameter	Symbol		Values			Unit	Note / Test Condition
			Min.	Typ.	Max.		
Storage temperature	T_{ST}	SR	-65	–	150	°C	–
Junction temperature	T_J	SR	-40	–	150	°C	–
Voltage at 3.3 V power supply pins with respect to V_{SS}	V_{DDP}	SR	–	–	4.3	V	–
Voltage on any Class A and dedicated input pin with respect to V_{SS}	V_{IN}	SR	-1.0	–	$V_{DDP} + 1.0$ or max. 4.3	V	whichever is lower
Voltage on any analog input pin with respect to V_{AGND}	V_{AIN} V_{AREF}	SR	-1.0	–	$V_{DDP} + 1.0$ or max. 4.3	V	whichever is lower
Input current on any pin during overload condition	I_{IN}	SR	-10	–	+10	mA	–
Absolute maximum sum of all input circuit currents for one port group during overload condition ¹⁾	ΣI_{IN}	SR	-25	–	+25	mA	–
Absolute maximum sum of all input circuit currents during overload condition	ΣI_{IN}	SR	-100	–	+100	mA	–

1) The port groups are defined in [Table 17](#).

Figure 10 explains the input voltage ranges of V_{IN} and V_{AIN} and its dependency to the supply level of V_{DDP} . The input voltage must not exceed 4.3 V, and it must not be more than 1.0 V above V_{DDP} . For the range up to $V_{DDP} + 1.0$ V also see the definition of the overload conditions in [Section 3.1.3](#).

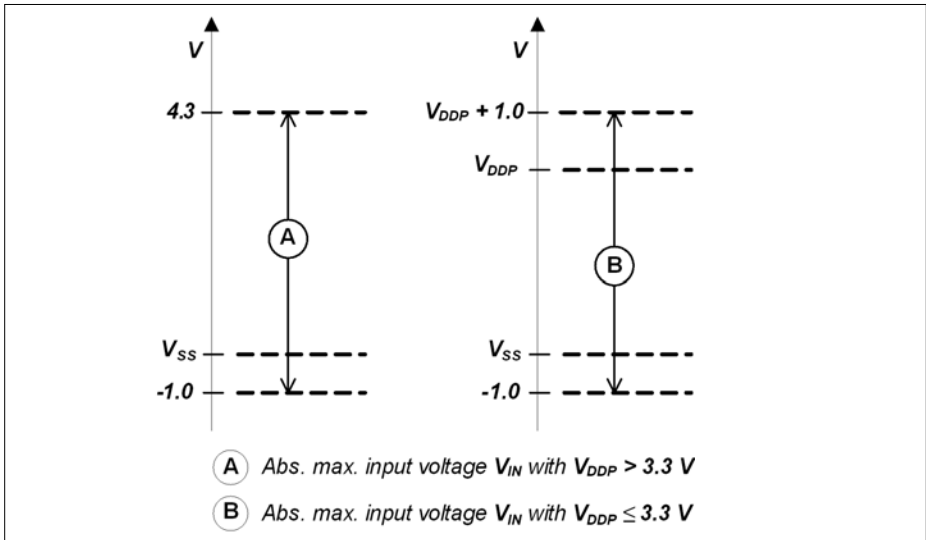

Figure 10 Absolute Maximum Input Voltage Ranges

3.1.3 Pin Reliability in Overload

When receiving signals from higher voltage devices, low-voltage devices experience overload currents and voltages that go beyond their own IO power supplies specification.

Table 14 defines overload conditions that will not cause any negative reliability impact if all the following conditions are met:

- full operation life-time is not exceeded
- **“Operating Conditions” on Page 49** are met for
 - pad supply levels (V_{DDP} or V_{DDA})
 - temperature

If a pin current is outside of the **“Operating Conditions” on Page 49** but within the overload conditions, then the parameters of this pin as stated in the Operating Conditions can no longer be guaranteed. Operation is still possible in most cases but with relaxed parameters.

Note: An overload condition on one or more pins does not require a reset.

Note: A series resistor at the pin to limit the current to the maximum permitted overload current is sufficient to handle failure situations like short to battery.

Table 14 **Overload Parameters**

Parameter	Symbol		Values			Unit	Note / Test Condition
			Min.	Typ.	Max.		
Input current on any port pin during overload condition	I_{OV}	SR	-5	–	5	mA	–
Absolute sum of all input circuit currents for one port group during overload condition ¹⁾	I_{OVG}	SR	–	–	20	mA	$\Sigma I_{OVx} $, for all $I_{OVx} < 0$ mA
			–	–	20	mA	$\Sigma I_{OVx} $, for all $I_{OVx} > 0$ mA
Absolute sum of all input circuit currents during overload condition	I_{OVs}	SR	–	–	80	mA	ΣI_{OVG}

1) The port groups are defined in [Table 17](#).

Figure 11 shows the path of the input currents during overload via the ESD protection structures. The diodes against V_{DDP} and ground are a simplified representation of these ESD protection structures.

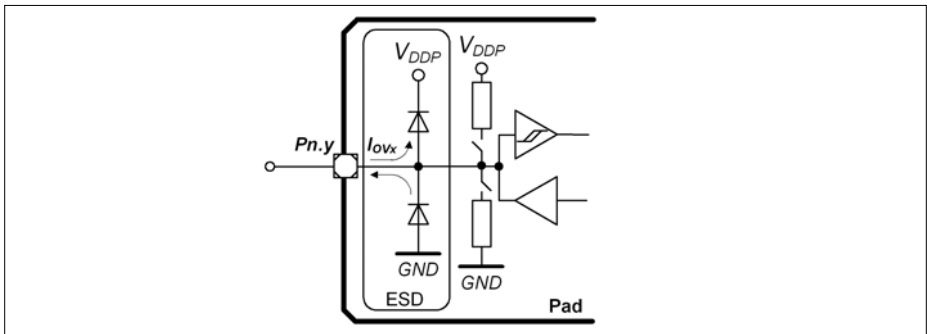

Figure 11 **Input Overload Current via ESD structures**

[Table 15](#) and [Table 16](#) list input voltages that can be reached under overload conditions. Note that the absolute maximum input voltages as defined in the “**Absolute Maximum Ratings**” on [Page 44](#) must not be exceeded during overload.

Table 15 PN-Junction Characteristics for positive Overload

Pad Type	$I_{OV} = 5 \text{ mA}, T_J = -40 \text{ }^\circ\text{C}$	$I_{OV} = 5 \text{ mA}, T_J = 150 \text{ }^\circ\text{C}$
A1 / A1+	$V_{IN} = V_{DDP} + 1.0 \text{ V}$	$V_{IN} = V_{DDP} + 0.75 \text{ V}$
A2	$V_{IN} = V_{DDP} + 0.7 \text{ V}$	$V_{IN} = V_{DDP} + 0.6 \text{ V}$
AN/DIG_IN	$V_{IN} = V_{DDP} + 1.0 \text{ V}$	$V_{IN} = V_{DDP} + 0.75 \text{ V}$

Table 16 PN-Junction Characteristics for negative Overload

Pad Type	$I_{OV} = 5 \text{ mA}, T_J = -40 \text{ }^\circ\text{C}$	$I_{OV} = 5 \text{ mA}, T_J = 150 \text{ }^\circ\text{C}$
A1 / A1+	$V_{IN} = V_{SS} - 1.0 \text{ V}$	$V_{IN} = V_{SS} - 0.75 \text{ V}$
A2	$V_{IN} = V_{SS} - 0.7 \text{ V}$	$V_{IN} = V_{SS} - 0.6 \text{ V}$
AN/DIG_IN	$V_{IN} = V_{DDP} - 1.0 \text{ V}$	$V_{IN} = V_{DDP} - 0.75 \text{ V}$

Table 17 Port Groups for Overload and Short-Circuit Current Sum Parameters

Group	Pins
1	P0.[15:0], P3.[15:0], P8.[11:0]
2	P14.[15:0], P15.[15:0]
3	P2.[15:0], P5.[11:0], P7[11:0]
4	P1.[15:0], P4.[7:0], P6.[6:0], P9.[11:0]

3.1.4 Pad Driver and Pad Classes Summary

This section gives an overview on the different pad driver classes and their basic characteristics.

Table 18 Pad Driver and Pad Classes Overview

Class	Power Supply	Type	Sub-Class	Speed Grade	Load	Termination
A	3.3 V	LVTTTL I/O	A1 (e.g. GPIO)	6 MHz	100 pF	No
			A1+ (e.g. serial I/Os)	25 MHz	50 pF	Series termination recommended
			A2 (e.g. ext. Bus)	80 MHz	15 pF	Series termination recommended

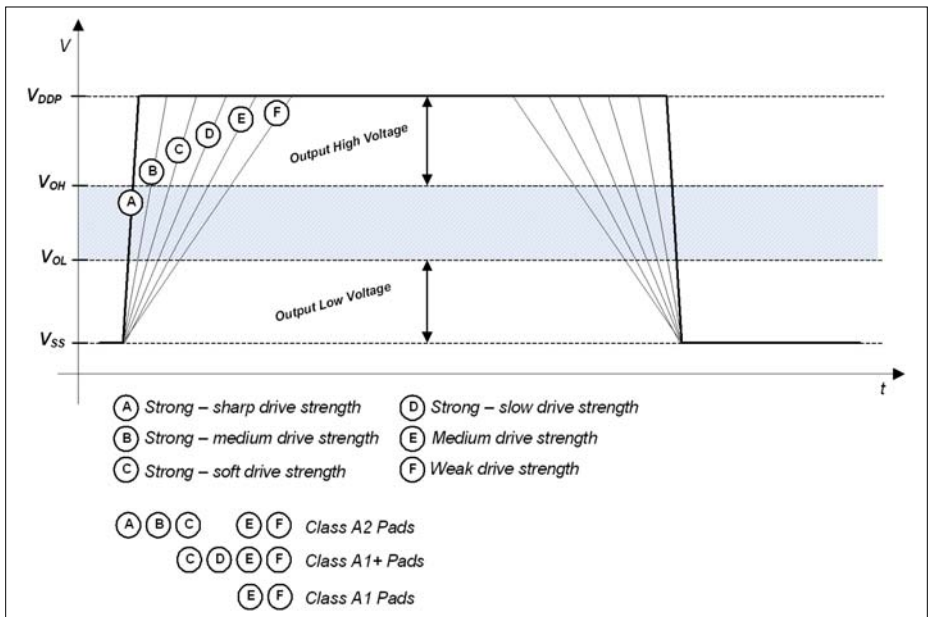

Figure 12 Output Slopes with different Pad Driver Modes

Figure 12 is a qualitative display of the resulting output slope performance with different output driver modes. The detailed input and output characteristics are listed in **Section 3.2.1**.

3.1.5 Operating Conditions

The following operating conditions must not be exceeded in order to ensure correct operation and reliability of the XMC4[78]00. All parameters specified in the following sections refer to these operating conditions, unless noted otherwise.

Table 19 Operating Conditions Parameters

Parameter	Symbol	Values			Unit	Note / Test Condition
		Min.	Typ.	Max.		
Ambient Temperature	T_A SR	-40	–	85	°C	Temp. Range F
		-40	–	125	°C	Temp. Range K
Digital supply voltage	V_{DDP} SR	3.13 ¹⁾	3.3	3.63 ²⁾	V	
Core Supply Voltage	V_{DDC} CC	– ¹⁾	1.3	–	V	Generated internally
Digital ground voltage	V_{SS} SR	0	–	–	V	
ADC analog supply voltage	V_{DDA} SR	3.0	3.3	3.6 ²⁾	V	
Analog ground voltage for V_{DDA}	V_{SSA} SR	-0.1	0	0.1	V	
Battery Supply Voltage for Hibernate Domain	V_{BAT} SR	1.95 ³⁾	–	3.63	V	When V_{DDP} is supplied V_{BAT} has to be supplied as well.
System Frequency	f_{SYS} SR	–	–	144	MHz	
Short circuit current of digital outputs	I_{SC} SR	-5	–	5	mA	
Absolute sum of short circuit currents per pin group ⁴⁾	ΣI_{SC_PG} SR	–	–	20	mA	
Absolute sum of short circuit currents of the device	ΣI_{SC_D} SR	–	–	100	mA	

1) See also the Supply Monitoring thresholds, [Section 3.3.2](#).

2) Voltage overshoot to 4.0 V is permissible at Power-Up and \overline{PORST} low, provided the pulse duration is less than 100 μ s and the cumulated sum of the pulses does not exceed 1 h over lifetime.

3) To start the hibernate domain it is required that $V_{BAT} \geq 2.1$ V, for a reliable start of the oscillation of RTC_XTAL in crystal mode it is required that $V_{BAT} \geq 3.0$ V.

4) The port groups are defined in [Table 17](#).

3.2 DC Parameters

3.2.1 Input/Output Pins

The digital input stage of the shared analog/digital input pins is identical to the input stage of the standard digital input/output pins.

The Pull-up on the $\overline{\text{PORST}}$ pin is identical to the Pull-up on the standard digital input/output pins.

Note: These parameters are not subject to production test, but verified by design and/or characterization.

Table 20 Standard Pad Parameters

Parameter	Symbol	Values		Unit	Note / Test Conditions
		Min.	Max.		
Pin capacitance (digital inputs/outputs)	C_{IO} CC	–	10	pF	–
Pull-down current	$ I_{PDL} $ SR	150	–	μA	¹⁾ $V_{IN} \geq 0.6 \times V_{DDP}$
		–	10	μA	²⁾ $V_{IN} \leq 0.36 \times V_{DDP}$
Pull-Up current	$ I_{PUH} $ SR	–	10	μA	²⁾ $V_{IN} \geq 0.6 \times V_{DDP}$
		100	–	μA	¹⁾ $V_{IN} \leq 0.36 \times V_{DDP}$
Input Hysteresis for pads of all A classes ³⁾	HYS_A CC	$0.1 \times V_{DDP}$	–	V	–
$\overline{\text{PORST}}$ spike filter always blocked pulse duration	t_{SF1} CC	–	10	ns	–
$\overline{\text{PORST}}$ spike filter pass-through pulse duration	t_{SF2} CC	100	–	ns	–
$\overline{\text{PORST}}$ pull-down current	$ I_{PPD} $ CC	13	–	mA	$V_{IN} = 1.0 \text{ V}$

1) Current required to override the pull device with the opposite logic level (“force current”).

With active pull device, at load currents between force and keep current the input state is undefined.

2) Load current at which the pull device still maintains the valid logic level (“keep current”).

With active pull device, at load currents between force and keep current the input state is undefined.

3) Hysteresis is implemented to avoid metastable states and switching due to internal ground bounce. It can not be guaranteed that it suppresses switching due to external system noise.

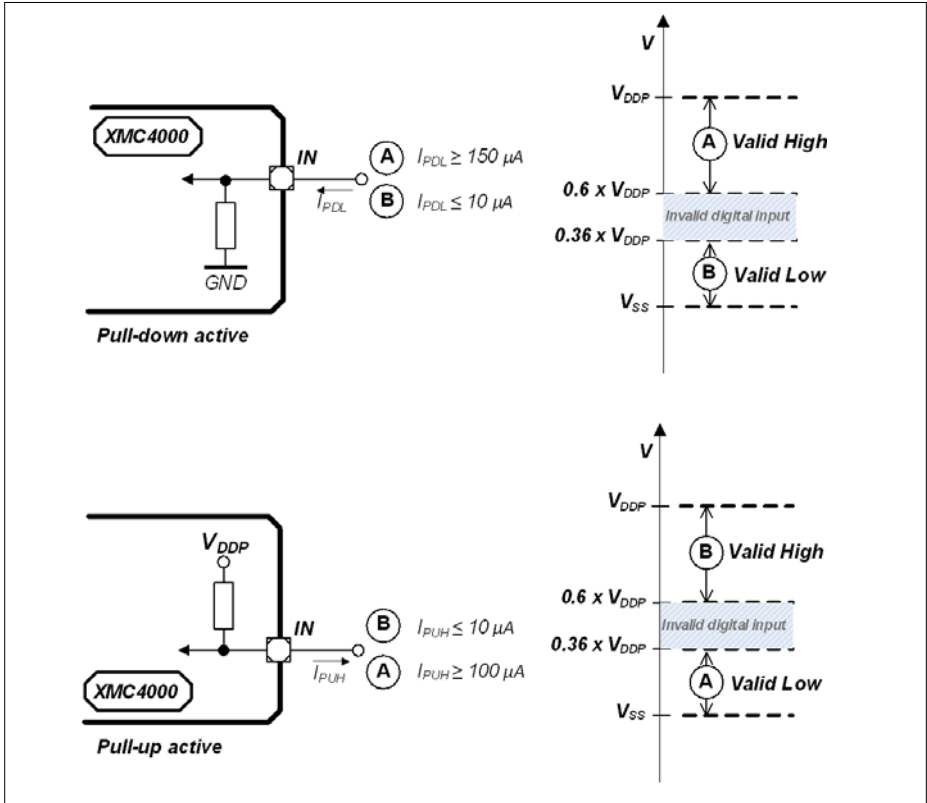

Figure 13 Pull Device Input Characteristics

Figure 13 visualizes the input characteristics with an active internal pull device:

- in the cases “A” the internal pull device is overridden by a strong external driver;
- in the cases “B” the internal pull device defines the input logical state against a weak external load.

Electrical Parameters
Table 21 Standard Pads Class_A1

Parameter	Symbol	Values		Unit	Note / Test Conditions
		Min.	Max.		
Input leakage current	I_{OZA1} CC	-500	500	nA	$0\text{ V} \leq V_{IN} \leq V_{DDP}$
Input high voltage	V_{IHA1} SR	$0.6 \times V_{DDP}$	$V_{DDP} + 0.3$	V	max. 3.6 V
Input low voltage	V_{ILA1} SR	-0.3	$0.36 \times V_{DDP}$	V	–
Output high voltage, POD ¹⁾ = weak	V_{OHA1} CC	$V_{DDP} - 0.4$	–	V	$I_{OH} \geq -400\ \mu\text{A}$
		2.4	–	V	$I_{OH} \geq -500\ \mu\text{A}$
Output high voltage, POD ¹⁾ = medium		$V_{DDP} - 0.4$	–	V	$I_{OH} \geq -1.4\ \text{mA}$
		2.4	–	V	$I_{OH} \geq -2\ \text{mA}$
Output low voltage	V_{OLA1} CC	–	0.4	V	$I_{OL} \leq 500\ \mu\text{A}$; POD ¹⁾ = weak
		–	0.4	V	$I_{OL} \leq 2\ \text{mA}$; POD ¹⁾ = medium
Fall time	t_{FA1} CC	–	150	ns	$C_L = 20\ \text{pF}$; POD ¹⁾ = weak
		–	50	ns	$C_L = 50\ \text{pF}$; POD ¹⁾ = medium
Rise time	t_{RA1} CC	–	150	ns	$C_L = 20\ \text{pF}$; POD ¹⁾ = weak
		–	50	ns	$C_L = 50\ \text{pF}$; POD ¹⁾ = medium

1) POD = Pin Out Driver

Table 22 Standard Pads Class_A1+

Parameter	Symbol	Values		Unit	Note / Test Conditions
		Min.	Max.		
Input leakage current	I_{OZA1+} CC	-1	1	μA	$0\text{ V} \leq V_{IN} \leq V_{DDP}$
Input high voltage	V_{IHA1+} SR	$0.6 \times V_{DDP}$	$V_{DDP} + 0.3$	V	max. 3.6 V
Input low voltage	V_{ILA1+} SR	-0.3	$0.36 \times V_{DDP}$	V	–

Electrical Parameters
Table 22 Standard Pads Class_A1+

Parameter	Symbol	Values		Unit	Note / Test Conditions	
		Min.	Max.			
Output high voltage, POD ¹⁾ = weak	V _{OHA1+} CC	V _{DDP} - 0.4	–	V	I _{OH} ≥ -400 μA	
		2.4	–	V	I _{OH} ≥ -500 μA	
Output high voltage, POD ¹⁾ = medium		V _{DDP} - 0.4	–	V	I _{OH} ≥ -1.4 mA	
		2.4	–	V	I _{OH} ≥ -2 mA	
Output high voltage, POD ¹⁾ = strong		V _{DDP} - 0.4	–	V	I _{OH} ≥ -1.4 mA	
		2.4	–	V	I _{OH} ≥ -2 mA	
Output low voltage		V _{OLA1+} CC	–	0.4	V	I _{OL} ≤ 500 μA; POD ¹⁾ = weak
			–	0.4	V	I _{OL} ≤ 2 mA; POD ¹⁾ = medium
	–		0.4	V	I _{OL} ≤ 2 mA; POD ¹⁾ = strong	
Fall time	t _{FA1+} CC	–	150	ns	C _L = 20 pF; POD ¹⁾ = weak	
		–	50	ns	C _L = 50 pF; POD ¹⁾ = medium	
		–	28	ns	C _L = 50 pF; POD ¹⁾ = strong; edge = slow	
		–	16	ns	C _L = 50 pF; POD ¹⁾ = strong; edge = soft;	
Rise time	t _{RA1+} CC	–	150	ns	C _L = 20 pF; POD ¹⁾ = weak	
		–	50	ns	C _L = 50 pF; POD ¹⁾ = medium	
		–	28	ns	C _L = 50 pF; POD ¹⁾ = strong; edge = slow	
		–	16	ns	C _L = 50 pF; POD ¹⁾ = strong; edge = soft	

1) POD = Pin Out Driver

Table 23 Standard Pads Class_A2

Parameter	Symbol	Values		Unit	Note / Test Conditions
		Min.	Max.		
Input Leakage current	I_{OZA2} CC	-6	6	μA	$0\text{ V} \leq V_{IN} < 0.5 \cdot V_{DDP} - 1\text{ V};$ $0.5 \cdot V_{DDP} + 1\text{ V} < V_{IN} \leq V_{DDP}$
		-3	3	μA	$0.5 \cdot V_{DDP} - 1\text{ V} < V_{IN} < 0.5 \cdot V_{DDP} + 1\text{ V}$
Input high voltage	V_{IHA2} SR	$0.6 \times V_{DDP}$	$V_{DDP} + 0.3$	V	max. 3.6 V
Input low voltage	V_{ILA2} SR	-0.3	$0.36 \times V_{DDP}$	V	–
Output high voltage, POD = weak	V_{OHA2} CC	$V_{DDP} - 0.4$	–	V	$I_{OH} \geq -400\ \mu\text{A}$
		2.4	–	V	$I_{OH} \geq -500\ \mu\text{A}$
Output high voltage, POD = medium		$V_{DDP} - 0.4$	–	V	$I_{OH} \geq -1.4\ \text{mA}$
		2.4	–	V	$I_{OH} \geq -2\ \text{mA}$
Output high voltage, POD = strong		$V_{DDP} - 0.4$	–	V	$I_{OH} \geq -1.4\ \text{mA}$
		2.4	–	V	$I_{OH} \geq -2\ \text{mA}$
Output low voltage, POD = weak	V_{OLA2} CC	–	0.4	V	$I_{OL} \leq 500\ \mu\text{A}$
Output low voltage, POD = medium		–	0.4	V	$I_{OL} \leq 2\ \text{mA}$
Output low voltage, POD = strong		–	0.4	V	$I_{OL} \leq 2\ \text{mA}$

Electrical Parameters

Table 23 Standard Pads Class_A2

Parameter	Symbol	Values		Unit	Note / Test Conditions
		Min.	Max.		
Fall time	t_{FA2} CC	–	150	ns	$C_L = 20$ pF; POD = weak
		–	50	ns	$C_L = 50$ pF; POD = medium
		–	3.7	ns	$C_L = 50$ pF; POD = strong; edge = sharp
		–	7	ns	$C_L = 50$ pF; POD = strong; edge = medium
		–	16	ns	$C_L = 50$ pF; POD = strong; edge = soft
Rise time	t_{RA2} CC	–	150	ns	$C_L = 20$ pF; POD = weak
		–	50	ns	$C_L = 50$ pF; POD = medium
		–	3.7	ns	$C_L = 50$ pF; POD = strong; edge = sharp
		–	7.0	ns	$C_L = 50$ pF; POD = strong; edge = medium
		–	16	ns	$C_L = 50$ pF; POD = strong; edge = soft

Table 24 HIB_IO Class_A1 special Pads

Parameter	Symbol	Values		Unit	Note / Test Condition
		Min.	Max.		
Input leakage current	I_{OZHIB} CC	-500	500	nA	$0\text{ V} \leq V_{IN} \leq V_{BAT}$
Input high voltage	V_{IHIB} SR	$0.6 \times V_{BAT}$	$V_{BAT} + 0.3$	V	max. 3.6 V
Input low voltage	V_{ILHIB} SR	-0.3	$0.36 \times V_{BAT}$	V	–
Input Hysteresis for HIB_IO pins ¹⁾	$HYSHIB$ CC	$0.1 \times V_{BAT}$	–	V	$V_{BAT} \geq 3.13\text{ V}$
		$0.06 \times V_{BAT}$	–	V	$V_{BAT} < 3.13\text{ V}$
Output high voltage, POD ¹⁾ = medium	V_{OHIB} CC	$V_{BAT} - 0.4$	–	V	$I_{OH} \geq -1.4\text{ mA}$
Output low voltage	V_{OLHIB} CC	–	0.4	V	$I_{OL} \leq 2\text{ mA}$
Fall time	t_{FHIB} CC	–	50	ns	$V_{BAT} \geq 3.13\text{ V}$ $C_L = 50\text{ pF}$
		–	100	ns	$V_{BAT} < 3.13\text{ V}$ $C_L = 50\text{ pF}$
Rise time	t_{RHIB} CC	–	50	ns	$V_{BAT} \geq 3.13\text{ V}$ $C_L = 50\text{ pF}$
		–	100	ns	$V_{BAT} < 3.13\text{ V}$ $C_L = 50\text{ pF}$

1) Hysteresis is implemented to avoid metastable states and switching due to internal ground bounce. It can not be guaranteed that it suppresses switching due to external system noise.

3.2.2 Analog to Digital Converters (VADC)

Note: These parameters are not subject to production test, but verified by design and/or characterization.

Table 25 VADC Parameters (Operating Conditions apply)

Parameter	Symbol	Values			Unit	Note / Test Conditions
		Min.	Typ.	Max.		
Analog reference voltage ⁵⁾	V_{AREF} SR	$V_{AGND} + 1$	–	$V_{DDA} + 0.05^{1)}$	V	–
Analog reference ground ⁵⁾	V_{AGND} SR	$V_{SSM} - 0.05$	–	$V_{AREF} - 1$	V	–
Analog reference voltage range ²⁾⁵⁾	$V_{AREF} - V_{AGND}$ SR	1	–	$V_{DDA} + 0.1$	V	–
Analog input voltage	V_{AIN} SR	V_{AGND}	–	V_{DDA}	V	–
Input leakage at analog inputs ³⁾	I_{OZ1} CC	-100	–	200	nA	$0.03 \times V_{DDA} < V_{AIN} < 0.97 \times V_{DDA}$
		-500	–	100	nA	$0 \text{ V} \leq V_{AIN} \leq 0.03 \times V_{DDA}$
		-100	–	500	nA	$0.97 \times V_{DDA} \leq V_{AIN} \leq V_{DDA}$
Input leakage current at VAREF	I_{OZ2} CC	-1	–	1	μA	$0 \text{ V} \leq V_{AREF} \leq V_{DDA}$
Input leakage current at VAGND	I_{OZ3} CC	-1	–	1	μA	$0 \text{ V} \leq V_{AGND} \leq V_{DDA}$
Internal ADC clock	f_{ADCI} CC	2	–	36	MHz	$V_{DDA} = 3.3 \text{ V}$
Switched capacitance at the analog voltage inputs ⁴⁾	C_{AINSW} CC	–	4	6.5	pF	–
Total capacitance of an analog input	C_{AINTOT} CC	–	12	20	pF	–
Switched capacitance at the positive reference voltage input ⁵⁾⁶⁾	C_{AREFSW} CC	–	15	30	pF	–
Total capacitance of the voltage reference inputs ⁵⁾	$C_{AREFTOT}$ CC	–	20	40	pF	–

Electrical Parameters
Table 25 VADC Parameters (Operating Conditions apply)

Parameter	Symbol	Values			Unit	Note / Test Conditions
		Min.	Typ.	Max.		
Total Unadjusted Error	TUE_{CC}	-4	–	4	LSB	12-bit resolution; $V_{DDA} = 3.3\text{ V}$; $V_{AREF} = V_{DDA}$ ⁷⁾
Differential Non-Linearity Error ⁸⁾	$EA_{DNL_{CC}}$	-3	–	3	LSB	
Gain Error ⁸⁾	$EA_{GAIN_{CC}}$	-4	–	4	LSB	
Integral Non-Linearity ⁸⁾	$EA_{INL_{CC}}$	-3	–	3	LSB	
Offset Error ⁸⁾	$EA_{OFF_{CC}}$	-4	–	4	LSB	
RMS Noise ⁹⁾	$EN_{RMS_{CC}}$	–	1	2 ^{10/11)}	LSB	–
Worst case ADC V_{DDA} power supply current per active converter	$I_{DDAA_{CC}}$	–	1.5	2	mA	during conversion $V_{DDP} = 3.6\text{ V}$, $T_J = 150\text{ °C}$
Charge consumption on V_{AREF} per conversion ⁵⁾	$Q_{CONV_{CC}}$	–	30	–	pC	$0\text{ V} \leq V_{AREF} \leq V_{DDA}$ ¹²⁾
ON resistance of the analog input path	$R_{AIN_{CC}}$	–	600	1 200	Ohm	–
ON resistance for the ADC test (pull down for AIN7)	$R_{AIN7T_{CC}}$	180	550	900	Ohm	–
Resistance of the reference voltage input path	$R_{AREF_{CC}}$	–	700	1 700	Ohm	–

- 1) A running conversion may become imprecise in case the normal conditions are violated (voltage overshoot).
- 2) If the analog reference voltage is below V_{DDA} , then the ADC converter errors increase. If the reference voltage is reduced by the factor k ($k < 1$), TUE, DNL, INL, Gain, and Offset errors increase also by the factor $1/k$.
- 3) The leakage current definition is a continuous function, as shown in figure ADCx Analog Inputs Leakage. The numerical values defined determine the characteristic points of the given continuous linear approximation - they do not define step function (see [Figure 16](#)).
- 4) The sampling capacity of the conversion C-network is pre-charged to $V_{AREF}/2$ before the sampling moment. Because of the parasitic elements, the voltage measured at AINx can deviate from $V_{AREF}/2$.
- 5) Applies to AINx, when used as alternate reference input.
- 6) This represents an equivalent switched capacitance. This capacitance is not switched to the reference voltage at once. Instead, smaller capacitances are successively switched to the reference voltage.
- 7) For 10-bit conversions, the errors are reduced to 1/4; for 8-bit conversions, the errors are reduced to 1/16. Never less than ± 1 LSB.
- 8) The sum of DNL/INL/GAIN/OFF errors does not exceed the related total unadjusted error TUE.

Electrical Parameters

- 9) This parameter is valid for soldered devices and requires careful analog board design.
- 10) Resulting worst case combined error is arithmetic combination of TUE and EN_{RMS} .
- 11) Value is defined for one sigma Gauss distribution.
- 12) The resulting current for a conversion can be calculated with $I_{AREF} = Q_{CONV} / t_c$.
The fastest 12-bit post-calibrated conversion of $t_c = 459$ ns results in a typical average current of $I_{AREF} = 65.4$ μ A.

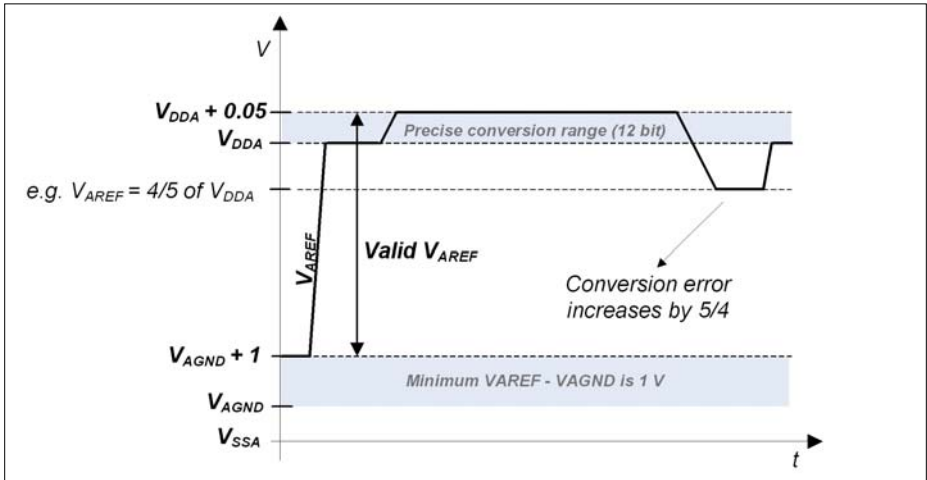

Figure 14 VADC Reference Voltage Range

The power-up calibration of the VADC requires a maximum number of $4 \cdot 352 \cdot f_{ADCI}$ cycles.

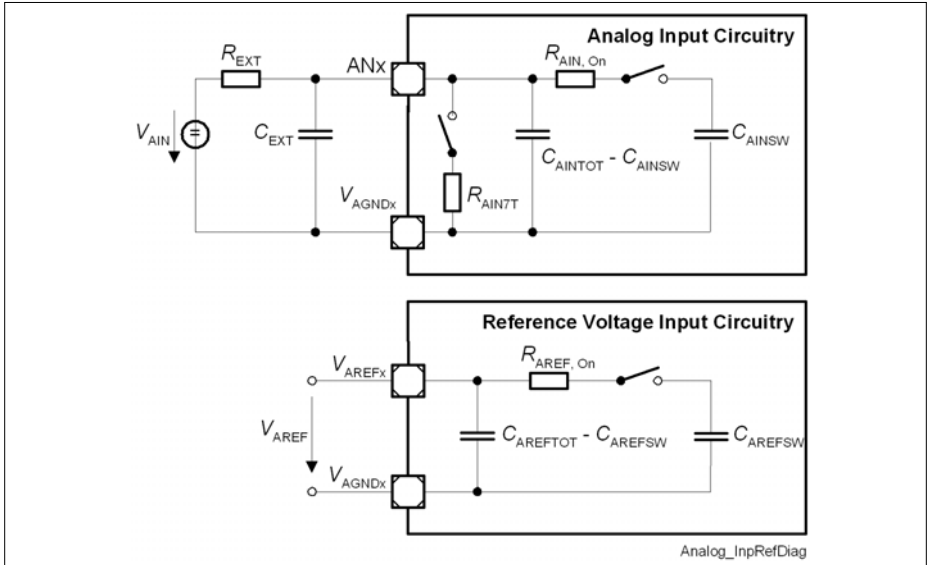

Figure 15 VADC Input Circuits

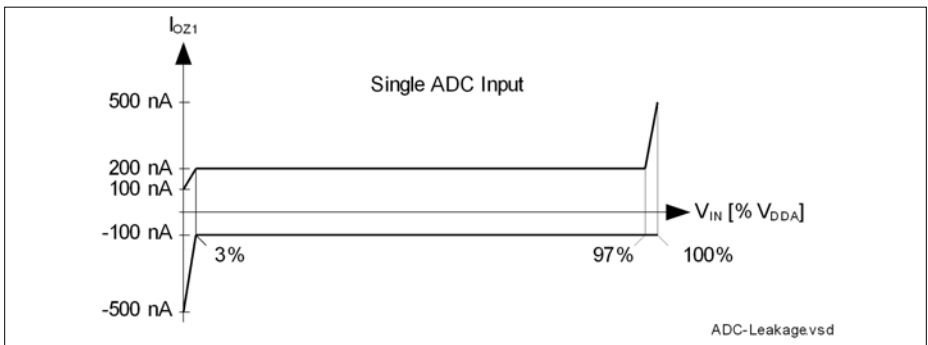

Figure 16 VADC Analog Input Leakage Current

Conversion Time

Table 26 Conversion Time (Operating Conditions apply)

Parameter	Symbol	Values	Unit	Note
Conversion time	t_C CC	$2 \times T_{ADC} + (2 + N + STC + PC + DM) \times T_{ADCI}$	μs	N = 8, 10, 12 for N-bit conversion $T_{ADC} = 1 / f_{PERIPH}$ $T_{ADCI} = 1 / f_{ADCI}$

- STC defines additional clock cycles to extend the sample time
- PC adds two cycles if post-calibration is enabled
- DM adds one cycle for an extended conversion time of the MSB

Conversion Time Examples

System assumptions:

$$f_{ADC} = 144 \text{ MHz i.e. } t_{ADC} = 6.9 \text{ ns, DIVA} = 3, f_{ADCI} = 36 \text{ MHz i.e. } t_{ADCI} = 27.8 \text{ ns}$$

According to the given formulas the following minimum conversion times can be achieved (STC = 0, DM = 0):

12-bit post-calibrated conversion (PC = 2):

$$t_{CN12C} = (2 + 12 + 2) \times t_{ADCI} + 2 \times t_{ADC} = 16 \times 27.8 \text{ ns} + 2 \times 6.9 \text{ ns} = 459 \text{ ns}$$

12-bit uncalibrated conversion:

$$t_{CN12} = (2 + 12) \times t_{ADCI} + 2 \times t_{ADC} = 14 \times 27.8 \text{ ns} + 2 \times 6.9 \text{ ns} = 403 \text{ ns}$$

10-bit uncalibrated conversion:

$$t_{CN10} = (2 + 10) \times t_{ADCI} + 2 \times t_{ADC} = 12 \times 27.8 \text{ ns} + 2 \times 6.9 \text{ ns} = 348 \text{ ns}$$

8-bit uncalibrated:

$$t_{CN8} = (2 + 8) \times t_{ADCI} + 2 \times t_{ADC} = 10 \times 27.8 \text{ ns} + 2 \times 6.9 \text{ ns} = 292 \text{ ns}$$

3.2.3 Digital to Analog Converters (DAC)

Note: These parameters are not subject to production test, but verified by design and/or characterization.

Electrical Parameters
Table 27 DAC Parameters (Operating Conditions apply)

Parameter	Symbol		Values			Unit	Note / Test Conditions
			Min.	Typ.	Max.		
RMS supply current	I_{DD}	CC	–	2.5	4	mA	per active DAC channel, without load currents of DAC outputs
Resolution	RES	CC	–	12	–	Bit	–
Update rate	f_{URATE_A}	CC	–		2	Msample/s	data rate, where DAC can follow 64 LSB code jumps to ± 1 LSB accuracy
Update rate	f_{URATE_F}	CC	–		5	Msample/s	data rate, where DAC can follow 64 LSB code jumps to ± 4 LSB accuracy
Settling time	t_{SETTLE}	CC	–	1	2	μ s	at full scale jump, output voltage reaches target value ± 20 LSB
Slew rate	SR	CC	2	5	–	V/ μ s	–
Minimum output voltage	V_{OUT_MIN}	CC	–	0.3	–	V	code value unsigned: 000 _H ; signed: 800 _H
Maximum output voltage	V_{OUT_MAX}	CC	–	2.5	–	V	code value unsigned: FFF _H ; signed: 7FF _H
Integral non-linearity	INL	CC	-5.5	± 2.5	5.5	LSB	$R_L \geq 5$ kOhm, $C_L \leq 50$ pF
Differential non-linearity	DNL	CC	-2	± 1	2	LSB	$R_L \geq 5$ kOhm, $C_L \leq 50$ pF
Offset error	ED_{OFF}	CC		± 20		mV	–
Gain error	ED_{G_IN}	CC	-6.5	-1.5	3	%	–
Startup time	$t_{STARTUP}$	CC	–	15	30	μ s	time from output enabling till code valid ± 16 LSB

Electrical Parameters
Table 27 DAC Parameters (Operating Conditions apply) (cont'd)

Parameter	Symbol		Values			Unit	Note / Test Conditions
			Min.	Typ.	Max.		
3dB Bandwidth of Output Buffer	f_{C1}	CC	2.5	5	–	MHz	verified by design
Output sourcing current	I_{OUT_SOURCE}	CC	–	-30	–	mA	–
Output sinking current	I_{OUT_SINK}	CC	–	0.6	–	mA	–
Output resistance	R_{OUT}	CC	–	50	–	Ohm	–
Load resistance	R_L	SR	5	–	–	kOhm	–
Load capacitance	C_L	SR	–	–	50	pF	–
Signal-to-Noise Ratio	SNR	CC	–	70	–	dB	Examination bandwidth < 25 kHz
Total Harmonic Distortion	THD	CC	–	70	–	dB	examination bandwidth < 25 kHz
Power Supply Rejection Ratio	PSRR	CC	–	56	–	dB	to V_{DDA} verified by design

Conversion Calculation

Unsigned:

$$DACxDATA = 4095 \times (V_{OUT} - V_{OUT_MIN}) / (V_{OUT_MAX} - V_{OUT_MIN})$$

Signed:

$$DACxDATA = 4095 \times (V_{OUT} - V_{OUT_MIN}) / (V_{OUT_MAX} - V_{OUT_MIN}) - 2048$$

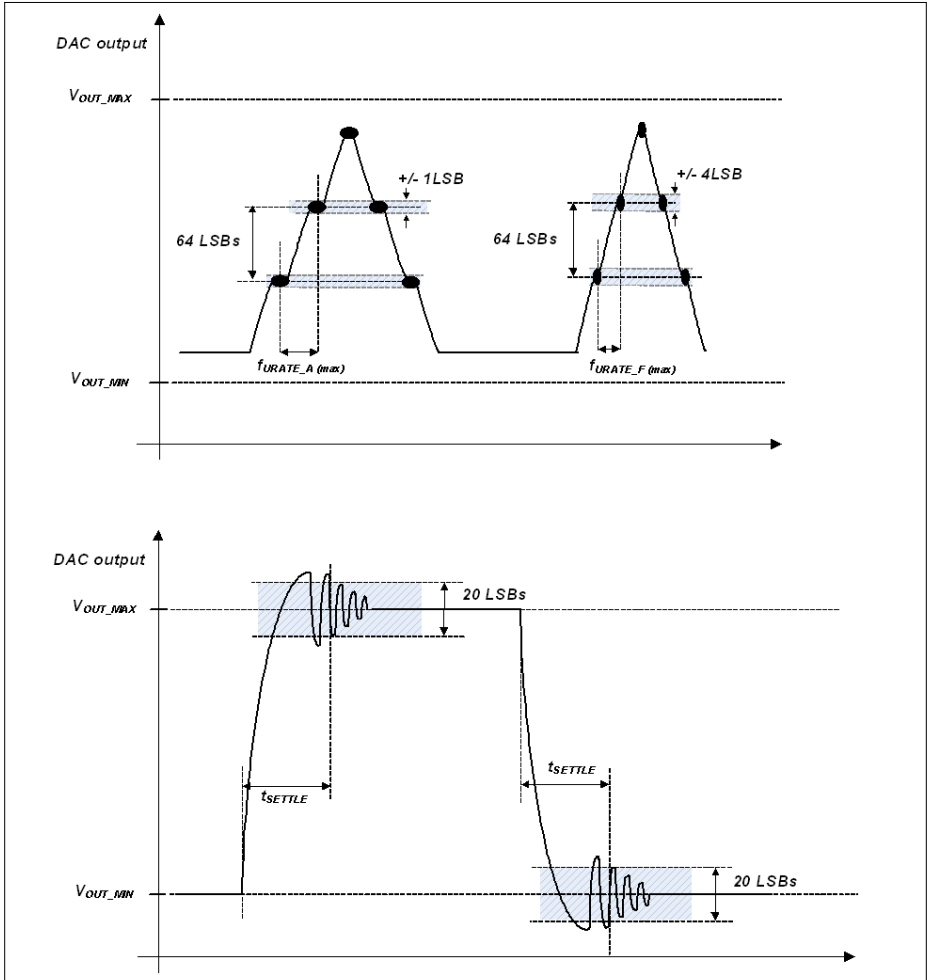

Figure 17 DAC Conversion Examples

3.2.4 Out-of-Range Comparator (ORC)

The Out-of-Range Comparator (ORC) triggers on analog input voltages (V_{AIN}) above the analog reference¹⁾ (V_{AREF}) on selected input pins (GxORCy) and generates a service request trigger (GxORCOUTy).

Note: These parameters are not subject to production test, but verified by design and/or characterization.

The parameters in **Table 28** apply for the maximum reference voltage $V_{AREF} = V_{DDA} + 50 \text{ mV}$.

Table 28 ORC Parameters (Operating Conditions apply)

Parameter	Symbol		Values			Unit	Note / Test Conditions
			Min.	Typ.	Max.		
DC Switching Level	V_{ODC}	CC	100	125	210	mV	$V_{AIN} \geq V_{AREF} + V_{ODC}$
Hysteresis	V_{OHYS}	CC	50	–	V_{ODC}	mV	
Detection Delay of a persistent Overvoltage	t_{ODD}	CC	50	–	450	ns	$V_{AIN} \geq V_{AREF} + 210 \text{ mV}$
			45	–	105	ns	$V_{AIN} \geq V_{AREF} + 400 \text{ mV}$
Always detected Overvoltage Pulse	t_{OPDD}	CC	440	–	–	ns	$V_{AIN} \geq V_{AREF} + 210 \text{ mV}$
			90	–	–	ns	$V_{AIN} \geq V_{AREF} + 400 \text{ mV}$
Never detected Overvoltage Pulse	t_{OPDN}	CC	–	–	45	ns	$V_{AIN} \geq V_{AREF} + 210 \text{ mV}$
			–	–	30	ns	$V_{AIN} \geq V_{AREF} + 400 \text{ mV}$
Release Delay	t_{ORD}	CC	65	–	105	ns	$V_{AIN} \leq V_{AREF}$
Enable Delay	t_{OED}	CC	–	100	200	ns	

1) Always the standard VADC reference, alternate references do not apply to the ORC.

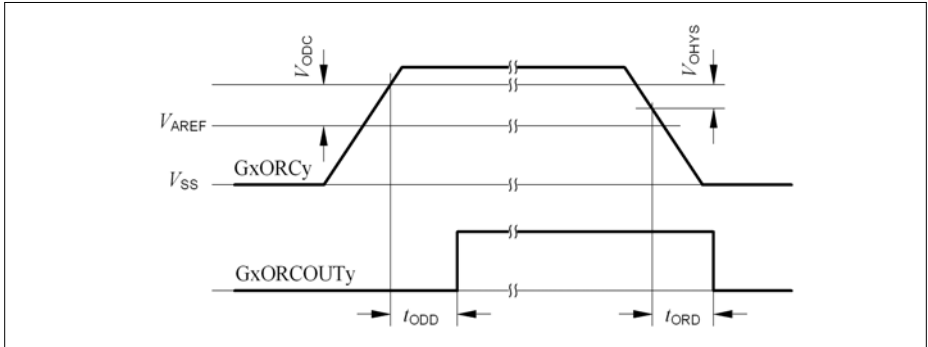

Figure 18 GxORCOUTy Trigger Generation

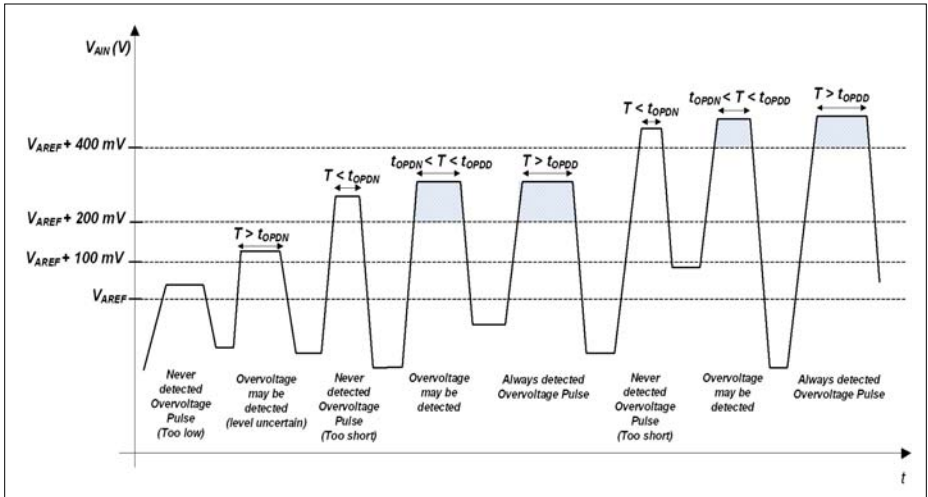

Figure 19 ORC Detection Ranges

3.2.5 Die Temperature Sensor

The Die Temperature Sensor (DTS) measures the junction temperature T_J .

Note: These parameters are not subject to production test, but verified by design and/or characterization.

Table 29 Die Temperature Sensor Parameters

Parameter	Symbol	Values			Unit	Note / Test Condition
		Min.	Typ.	Max.		
Temperature sensor range	T_{SR} SR	-40	–	150	°C	–
Linearity Error (to the below defined formula)	ΔT_{LE} CC	–	± 1	–	°C	per $\Delta T_J \leq 30$ °C
Offset Error	ΔT_{OE} CC	–	± 6	–	°C	$\Delta T_{OE} = T_J - T_{DTS}$ $V_{DDP} \leq 3.3$ V ¹⁾
Measurement time	t_M CC	–	–	100	μs	–
Start-up time after reset inactive	t_{TSST} SR	–	–	10	μs	–

1) At $V_{DDP_max} = 3.63$ V the typical offset error increases by an additional $\Delta T_{OE} = \pm 1$ °C.

The following formula calculates the temperature measured by the DTS in [°C] from the RESULT bit field of the DTSSTAT register.

$$\text{Temperature } T_{DTS} = (\text{RESULT} - 605) / 2.05 \text{ [°C]}$$

This formula and the values defined in **Table 29** apply with the following calibration values:

- DTSCON.BGTRIM = δ_H
- DTSCON.REFTRIM = 4_H

3.2.6 USB OTG Interface DC Characteristics

The Universal Serial Bus (USB) Interface is compliant to the USB Rev. 2.0 Specification and the OTG Specification Rev. 1.3. High-Speed Mode is not supported.

Note: These parameters are not subject to production test, but verified by design and/or characterization.

Table 30 USB OTG VBUS and ID Parameters (Operating Conditions apply)

Parameter	Symbol	Values			Unit	Note / Test Conditions
		Min.	Typ.	Max.		
VBUS input voltage range	V_{IN} CC	0.0	–	5.25	V	–
A-device VBUS valid threshold	V_{B1} CC	4.4	–	–	V	–
A-device session valid threshold	V_{B2} CC	0.8	–	2.0	V	–
B-device session valid threshold	V_{B3} CC	0.8	–	4.0	V	–
B-device session end threshold	V_{B4} CC	0.2	–	0.8	V	–
VBUS input resistance to ground	R_{VBUS_IN} CC	40	–	100	kOhm	–
B-device VBUS pull-up resistor	R_{VBUS_PU} CC	281	–	–	Ohm	Pull-up voltage = 3.0 V
B-device VBUS pull-down resistor	R_{VBUS_PD} CC	656	–	–	Ohm	–
USB.ID pull-up resistor	R_{UID_PU} CC	14	–	25	kOhm	–
VBUS input current	I_{VBUS_IN} CC	–	–	150	μ A	$0\text{ V} \leq V_{IN} \leq 5.25\text{ V}$: $T_{AVG} = 1\text{ ms}$

Table 31 USB OTG Data Line (USB_DP, USB_DM) Parameters (Operating Conditions apply)

Parameter	Symbol	Values			Unit	Note / Test Condition
		Min.	Typ.	Max.		
Input low voltage	V_{IL} SR	–	–	0.8	V	–
Input high voltage (driven)	V_{IH} SR	2.0	–	–	V	–
Input high voltage (floating) ¹⁾	V_{IHZ} SR	2.7	–	3.6	V	–
Differential input sensitivity	V_{DIS} CC	0.2	–	–	V	–
Differential common mode range	V_{CM} CC	0.8	–	2.5	V	–
Output low voltage	V_{OL} CC	0.0	–	0.3	V	1.5 kOhm pull-up to 3.6 V
Output high voltage	V_{OH} CC	2.8	–	3.6	V	15 kOhm pull-down to 0 V
DP pull-up resistor (idle bus)	R_{PUI} CC	900	–	1 575	Ohm	–
DP pull-up resistor (upstream port receiving)	R_{PUA} CC	1 425	–	3 090	Ohm	–
DP, DM pull-down resistor	R_{PD} CC	14.25	–	24.8	kOhm	–
Input impedance DP, DM	Z_{INP} CC	300	–	–	kOhm	$0 V \leq V_{IN} \leq V_{DDP}$
Driver output resistance DP, DM	Z_{DRV} CC	28	–	44	Ohm	–

1) Measured at A-connector with 1.5 kOhm \pm 5% to 3.3 V \pm 0.3 V connected to USB_DP or USB_DM and at B-connector with 15 kOhm \pm 5% to ground connected to USB_DP and USB_DM.

3.2.7 Oscillator Pins

Note: It is strongly recommended to measure the oscillation allowance (negative resistance) in the final target system (layout) to determine the optimal parameters for the oscillator operation. Please refer to the limits specified by the crystal or ceramic resonator supplier.

Note: These parameters are not subject to production test, but verified by design and/or characterization.

The oscillator pins can be operated with an external crystal (see [Figure 20](#)) or in direct input mode (see [Figure 21](#)).

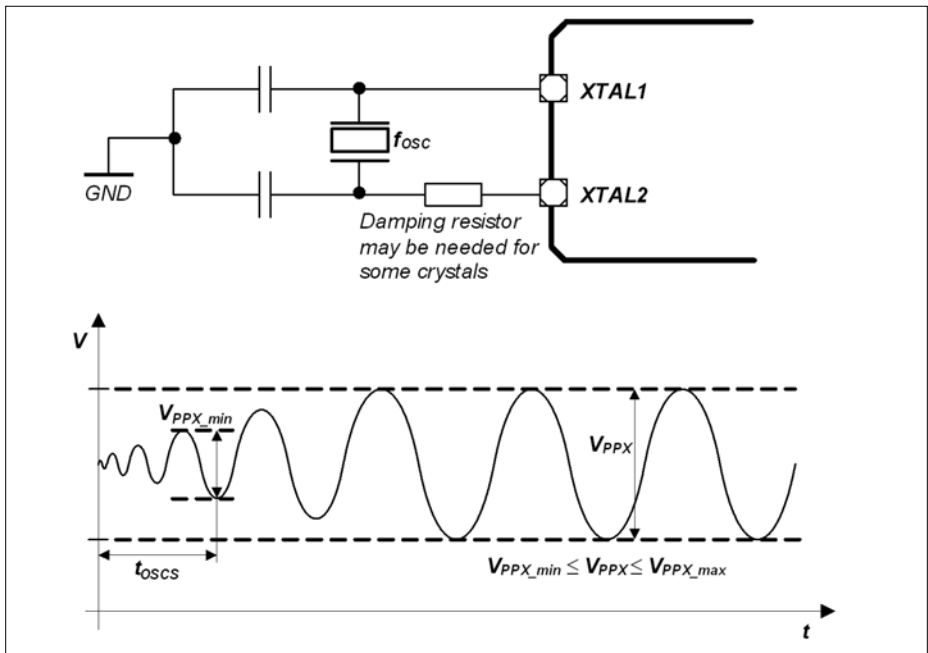

Figure 20 Oscillator in Crystal Mode

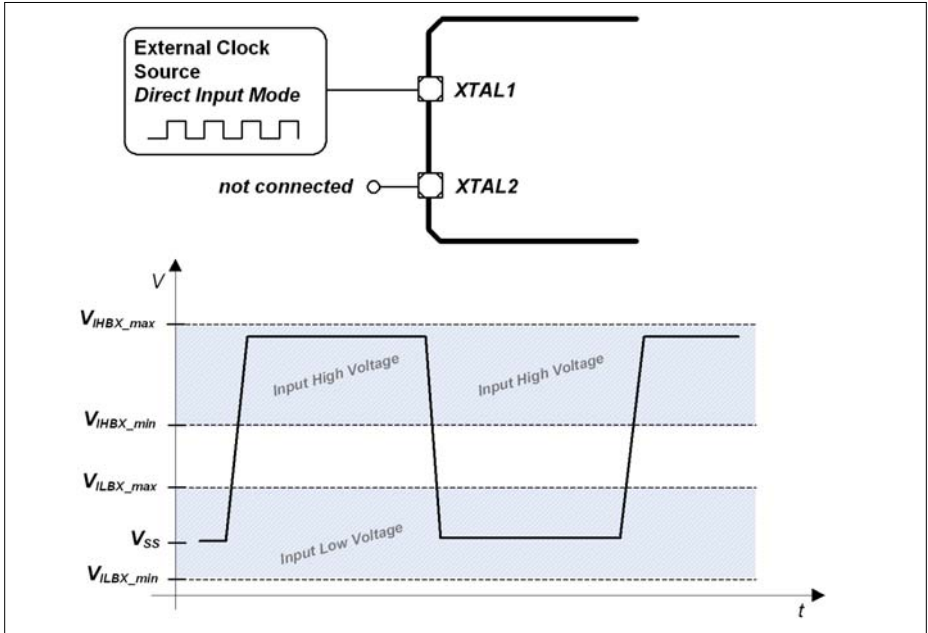

Figure 21 Oscillator in Direct Input Mode

Table 32 OSC_XTAL Parameters

Parameter	Symbol	Values			Unit	Note / Test Conditions
		Min.	Typ.	Max.		
Input frequency	f_{OSC} SR	4	–	40	MHz	Direct Input Mode selected
		4	–	25	MHz	External Crystal Mode selected
Oscillator start-up time ¹⁾²⁾	t_{OSCS} CC	–	–	10	ms	–
Input voltage at XTAL1	V_{IX} SR	-0.5	–	$V_{\text{DDP}} + 0.5$	V	–
Input amplitude (peak-to-peak) at XTAL1 ²⁾³⁾	V_{PPX} SR	$0.4 \times V_{\text{DDP}}$	–	$V_{\text{DDP}} + 1.0$	V	–
Input high voltage at XTAL1 ⁴⁾	V_{IHBX} SR	1.0	–	$V_{\text{DDP}} + 0.5$	V	–
Input low voltage at XTAL1 ⁴⁾	V_{ILBX} SR	-0.5	–	0.4	V	–
Input leakage current at XTAL1	I_{ILX1} CC	-100	–	100	nA	Oscillator power down $0 \text{ V} \leq V_{\text{IX}} \leq V_{\text{DDP}}$

1) t_{OSCS} is defined from the moment the oscillator is enabled with SCU_OSCHPCTRL.MODE until the oscillations reach an amplitude at XTAL1 of $0.4 \times V_{\text{DDP}}$.

2) The external oscillator circuitry must be optimized by the customer and checked for negative resistance and amplitude as recommended and specified by crystal suppliers.

3) If the shaper unit is enabled and not bypassed.

4) If the shaper unit is bypassed, dedicated DC-thresholds have to be met.

Table 33 RTC_XTAL Parameters

Parameter	Symbol	Values			Unit	Note / Test Conditions
		Min.	Typ.	Max.		
Input frequency	f_{OSC} SR	–	32.768	–	kHz	–
Oscillator start-up time ¹⁾²⁾³⁾	t_{OSCS} CC	–	–	5	s	–
Input voltage at RTC_XTAL1	V_{IX} SR	-0.3	–	$V_{BAT} + 0.3$	V	–
Input amplitude (peak-to-peak) at RTC_XTAL1 ²⁾⁴⁾	V_{PPX} SR	0.4	–	–	V	–
Input high voltage at RTC_XTAL1 ⁵⁾	V_{IHBX} SR	$0.6 \times V_{BAT}$	–	$V_{BAT} + 0.3$	V	–
Input low voltage at RTC_XTAL1 ⁵⁾	V_{ILBX} SR	-0.3	–	$0.36 \times V_{BAT}$	V	–
Input Hysteresis for RTC_XTAL1 ⁵⁾⁶⁾	V_{HYSX} CC	$0.1 \times V_{BAT}$	–	–	V	$3.0 \text{ V} \leq V_{BAT} < 3.6 \text{ V}$
		$0.03 \times V_{BAT}$	–	–	V	$V_{BAT} < 3.0 \text{ V}$
Input leakage current at RTC_XTAL1	I_{ILX1} CC	-100	–	100	nA	Oscillator power down $0 \text{ V} \leq V_{IX} \leq V_{BAT}$

- t_{OSCS} is defined from the moment the oscillator is enabled by the user with SCU_OSCULCTRL.MODE until the oscillations reach an amplitude at RTC_XTAL1 of 400 mV.
- The external oscillator circuitry must be optimized by the customer and checked for negative resistance and amplitude as recommended and specified by crystal suppliers.
- For a reliable start of the oscillation in crystal mode it is required that $V_{BAT} \geq 3.0 \text{ V}$. A running oscillation is maintained across the full V_{BAT} voltage range.
- If the shaper unit is enabled and not bypassed.
- If the shaper unit is bypassed, dedicated DC-thresholds have to be met.
- Hysteresis is implemented to avoid metastable states and switching due to internal ground bounce. It can not be guaranteed that it suppresses switching due to external system noise.

3.2.8 Power Supply Current

The total power supply current defined below consists of a leakage and a switching component.

Application relevant values are typically lower than those given in the following tables, and depend on the customer's system operating conditions (e.g. thermal connection or used application configurations).

Note: These parameters are not subject to production test, but verified by design and/or characterization.

If not stated otherwise, the operating conditions for the parameters in the following table are:

$$V_{DDP} = 3.3 \text{ V}, T_A = 25 \text{ }^\circ\text{C}$$

Table 34 Power Supply Parameters

Parameter	Symbol	Values			Unit	Note / Test Condition
		Min.	Typ.	Max.		
Active supply current ¹⁾¹¹⁾ Peripherals enabled Frequency: $f_{CPU} / f_{PERIPH} / f_{CCU}$ in MHz	I_{DDPA} CC	–	135	–	mA	144 / 144 / 144
		–	125	–		144 / 72 / 72
		–	97	–		72 / 72 / 144
		–	80	–		24 / 24 / 24
		–	68	–		1 / 1 / 1
Active supply current Code execution from RAM Flash in Sleep mode	I_{DDPA} CC	–	108	–	mA	144 / 144 / 144
		–	98	–		144 / 72 / 72
Active supply current ²⁾ Peripherals disabled Frequency: $f_{CPU} / f_{PERIPH} / f_{CCU}$ in MHz	I_{DDPA} CC	–	86	–	mA	144 / 144 / 144
		–	85	–		144 / 72 / 72
		–	70	–		72 / 72 / 144
		–	55	–		24 / 24 / 24
		–	50	–		1 / 1 / 1
Sleep supply current ³⁾ Peripherals enabled Frequency: $f_{CPU} / f_{PERIPH} / f_{CCU}$ in MHz	I_{DDPS} CC	–	127	–	mA	144 / 144 / 144
		–	115	–		144 / 72 / 72
		–	93	–		72 / 72 / 144
		–	57	–		24 / 24 / 24
		–	47	–		1 / 1 / 1
		$f_{CPU} / f_{PERIPH} / f_{CCU}$ in kHz	–	48		–

Electrical Parameters
Table 34 Power Supply Parameters

Parameter	Symbol	Values			Unit	Note / Test Condition
		Min.	Typ.	Max.		
Sleep supply current ⁴⁾ Peripherals disabled Frequency: $f_{CPU} / f_{PERIPH} / f_{CCU}$ in MHz	I_{DDPS} CC	–	77	–	mA	144 / 144 / 144
		–	76	–		144 / 72 / 72
		–	65	–		72 / 72 / 144
		–	53	–		24 / 24 / 24
		–	46	–		1 / 1 / 1
		–	47	–		100 / 100 / 100
$f_{CPU} / f_{PERIPH} / f_{CCU}$ in kHz Deep Sleep supply current ⁵⁾ Flash in Sleep mode Frequency: $f_{CPU} / f_{PERIPH} / f_{CCU}$ in MHz $f_{CPU} / f_{PERIPH} / f_{CCU}$ in kHz	I_{DDPD} CC	–	11	–	mA	24 / 24 / 24
		–	7.0	–		4 / 4 / 4
		–	6.6	–		1 / 1 / 1
		–	7.6	–		100 / 100 / 100 ⁶⁾
Hibernate supply current RTC on ⁷⁾	I_{DDPH} CC	–	8.7	–	μ A	$V_{BAT} = 3.3$ V
		–	6.5	–		$V_{BAT} = 2.4$ V
		–	5.7	–		$V_{BAT} = 2.0$ V
Hibernate supply current RTC off ⁸⁾	I_{DDPH} CC	–	8.0	–	μ A	$V_{BAT} = 3.3$ V
		–	6.0	–		$V_{BAT} = 2.4$ V
		–	5.0	–		$V_{BAT} = 2.0$ V
Hibernate off ⁹⁾	I_{DDPH} CC	–	4.4	–	μ A	$V_{BAT} = 3.3$ V
		–	3.5	–		$V_{BAT} = 2.4$ V
		–	3.1	–		$V_{BAT} = 2.0$ V
Worst case active supply current ¹⁰⁾	I_{DDPA} CC	–	–	250 ¹¹⁾	mA	$V_{DDP} = 3.6$ V, $T_J = 150$ °C
V_{DDA} power supply current	I_{DDA} CC	–	–	–	mA	–
I_{DDP} current at PORST Low	I_{DDP_PORST} CC	–	5	10	mA	$V_{DDP} = 3.3$ V, $T_J = 25$ °C
		–	13	55	mA	$V_{DDP} = 3.6$ V, $T_J = 150$ °C
Power Dissipation	P_{DISS} CC	–	–	1.4	W	$V_{DDP} = 3.6$ V, $T_J = 150$ °C

Table 34 Power Supply Parameters

Parameter	Symbol	Values			Unit	Note / Test Condition
		Min.	Typ.	Max.		
Wake-up time from Sleep to Active mode	t_{SSA} CC	–	6	–	cycles	
Wake-up time from Deep Sleep to Active mode		–	–	–	ms	Defined by the wake-up of the Flash module, see Section 3.2.9
Wake-up time from Hibernate mode		–	–	–	ms	Wake-up via power-on reset event, see Section 3.3.2

- 1) CPU executing code from Flash, all peripherals idle.
- 2) CPU executing code from Flash.
- 3) CPU in sleep, all peripherals idle, Flash in Active mode.
- 4) CPU in sleep, Flash in Active mode.
- 5) CPU in sleep, peripherals disabled, after wake-up code execution from RAM.
- 6) To wake-up the Flash from its Sleep mode, $f_{CPU} \geq 1$ MHz is required.
- 7) OSC_ULP operating with external crystal on RTC_XTAL
- 8) OSC_ULP off, Hibernate domain operating with OSC_SI clock
- 9) V_{BAT} supplied, but Hibernate domain not started; for example state after factory assembly
- 10) Test Power Loop: $f_{SYS} = 144$ MHz, CPU executing benchmark code from Flash, all CCUs in 100kHz timer mode, all ADC groups in continuous conversion mode, USICs as SPI in internal loop-back mode, CAN in 500kHz internal loop-back mode, interrupt triggered DMA block transfers to parity protected RAMs and FCE, DTS measurements and FPU calculations.
 The power consumption of each customer application will most probably be lower than this value, but must be evaluated separately.
- 11) I_{DDP} decreases typically by approximately 5 mA when f_{SYS} decreases by 10 MHz, at constant T_J

Peripheral Idle Currents

Default test conditions:

- f_{sys} and derived clocks at 144 MHz
- $V_{DDP} = 3.3\text{ V}$, $T_a = 25\text{ °C}$
- all peripherals are held in reset (see the PRSTAT registers in the Reset Control Unit of the SCU)
- the peripheral clocks are disabled (see CGATSTAT registers in the Clock Control Unit of the SCU)
- no I/O activity

The given values are a result of differential measurements with asserted and deasserted peripheral reset as well as disabled and enabled clock of the peripheral under test.

The tested peripheral is left in the state after the peripheral reset is deasserted, no further initialisation or configuration is done. E.g. no timer is running in the CCUs, no communication active in the USICs, etc.

Table 35 Peripheral Idle Currents

Parameter	Symbol	Values			Unit	Note / Test Conditions
		Min.	Typ.	Max.		
PORTS FCE WDT POSIFx ¹⁾	$I_{PER\ CC}$	–	≤ 0.3	–	mA	–
MultiCAN ERU LEDTSCU0 ETH CCU4x ¹⁾ , CCU8x ¹⁾		–	≤ 1.0	–		–
DAC (digital) ²⁾		–	1.3	–		–
USICx DMA1 SDMMC		–	3.0	–		–
DSD, EBU VADC (digital) ²⁾		–	4.5	–		–
DMA0, USB, EtherCAT		–	6.0	–		–

1) Enabling the f_{CCU} clock for the POSIFx/CCU4x/CCU8x modules adds approximately $I_{PER} = 4.8\text{ mA}$, disregarding which and how many of those peripherals are enabled.

2) The current consumption of the analog components are given in the dedicated Data Sheet sections of the respective peripheral.

3.2.9 Flash Memory Parameters

Note: These parameters are not subject to production test, but verified by design and/or characterization.

Table 36 Flash Memory Parameters

Parameter	Symbol	Values			Unit	Note / Test Conditions
		Min.	Typ.	Max.		
Erase Time per 256 Kbyte Sector	t_{ERP} CC	–	5	5.5	s	–
Erase Time per 64 Kbyte Sector	t_{ERP} CC	–	1.2	1.4	s	–
Erase Time per 16 Kbyte Logical Sector	t_{ERP} CC	–	0.3	0.4	s	–
Program time per page ¹⁾	t_{PRP} CC	–	5.5	11	ms	–
Erase suspend delay	t_{FL_ErSusp} CC	–	–	15	ms	–
Wait time after margin change	$t_{FL_MarginDel}$ CC	10	–	–	μs	–
Wake-up time	t_{WU} CC	–	–	270	μs	–
Read access time	t_a CC	22	–	–	ns	For operation with $1/f_{CPU} < t_a$ wait states must be configured ²⁾
Data Retention Time, Physical Sector ³⁾⁴⁾	t_{RET} CC	20	–	–	years	Max. 1000 erase/program cycles
Data Retention Time, Logical Sector ³⁾⁴⁾	t_{RETL} CC	20	–	–	years	Max. 100 erase/program cycles
Data Retention Time, User Configuration Block (UCB) ³⁾⁴⁾	t_{RTU} CC	20	–	–	years	Max. 4 erase/program cycles per UCB
Endurance on 64 Kbyte Physical Sector PS4	N_{EPS4} CC	10000	–	–	cycles	Cycling distributed over life time ⁵⁾

Electrical Parameters

- 1) In case the Program Verify feature detects weak bits, these bits will be programmed once more. The reprogramming takes an additional time of 5.5 ms.
- 2) The following formula applies to the wait state configuration: $FCON.WSPFLASH \times (1 / f_{CPU}) \geq t_a$.
- 3) Storage and inactive time included.
- 4) Values given are valid for an average weighted junction temperature of $T_J = 110^\circ\text{C}$.
- 5) Only valid with robust EEPROM emulation algorithm, equally cycling the logical sectors. For more details see the Reference Manual.

3.3 AC Parameters

3.3.1 Testing Waveforms

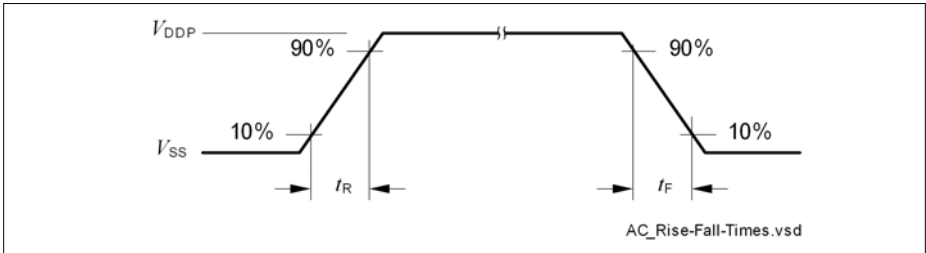

Figure 22 Rise/Fall Time Parameters

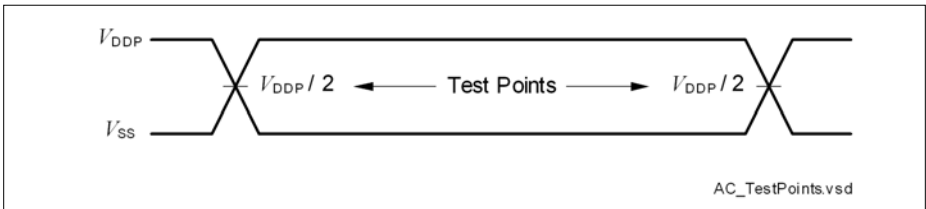

Figure 23 Testing Waveform, Output Delay

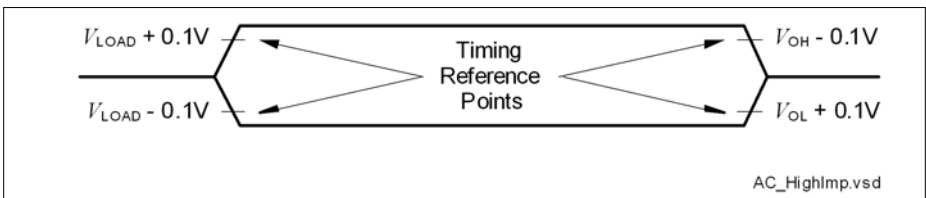

Figure 24 Testing Waveform, Output High Impedance

3.3.2 Power-Up and Supply Monitoring

$\overline{\text{PORST}}$ is always asserted when V_{DDP} and/or V_{DDC} violate the respective thresholds.

Note: These parameters are not subject to production test, but verified by design and/or characterization.

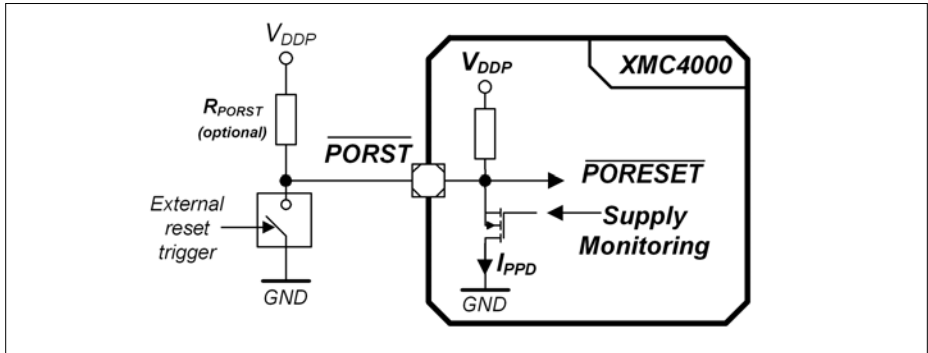

Figure 25 $\overline{\text{PORST}}$ Circuit

Table 37 Supply Monitoring Parameters

Parameter	Symbol	Values			Unit	Note / Test Condition
		Min.	Typ.	Max.		
Digital supply voltage reset threshold	V_{POR} CC	2.79 ¹⁾	–	3.05 ²⁾	V	3)
Core supply voltage reset threshold	V_{PV} CC	–	–	1.17	V	–
V_{DDP} voltage to ensure defined pad states	V_{DDPPA} CC	–	1.0	–	V	–
$\overline{\text{PORST}}$ rise time	t_{PR} SR	–	–	2	μs	4)
Startup time from power-on reset with code execution from Flash	t_{SSW} CC	–	2.5	3.5	ms	Time to the first user code instruction
V_{DDC} ramp up time	t_{VCR} CC	–	550	–	μs	Ramp up after power-on or after a reset triggered by a violation of V_{POR} or V_{PV}

1) Minimum threshold for reset assertion.

- 2) Maximum threshold for reset deassertion.
- 3) The V_{DDP} monitoring has a typical hysteresis of $V_{PORHYS} = 180$ mV.
- 4) If t_{PR} is not met, low spikes on \overline{PORST} may be seen during start up (e.g. reset pulses generated by the supply monitoring due to a slow ramping V_{DDP}).

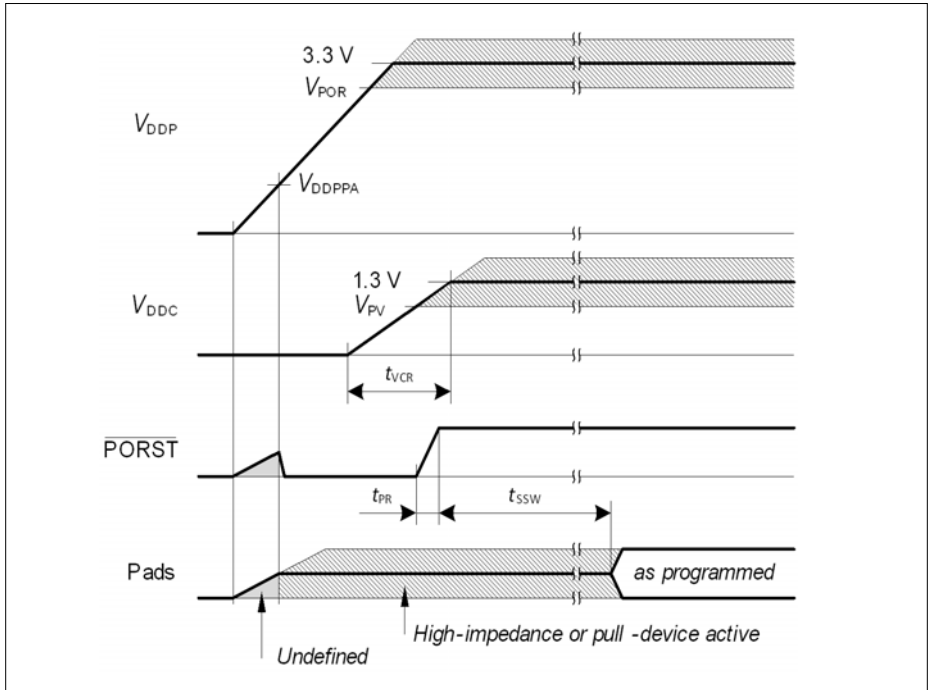

Figure 26 Power-Up Behavior

3.3.3 Power Sequencing

While starting up and shutting down as well as when switching power modes of the system it is important to limit the current load steps. A typical cause for such load steps is changing the CPU frequency f_{CPU} . Load steps exceeding the below defined values may cause a power on reset triggered by the supply monitor.

Note: These parameters are not subject to production test, but verified by design and/or characterization.

Table 38 Power Sequencing Parameters

Parameter	Symbol	Values			Unit	Note / Test Condition
		Min.	Typ.	Max.		
Positive Load Step Current	ΔI_{PLS} SR	–	–	50	mA	Load increase on V_{DDP} $\Delta t \leq 10$ ns
Negative Load Step Current	ΔI_{NLS} SR	–	–	150	mA	Load decrease on V_{DDP} $\Delta t \leq 10$ ns
V_{DDC} Voltage Over- / Undershoot from Load Step	ΔV_{LS} CC	–	–	± 100	mV	For maximum positive or negative load step
Positive Load Step Settling Time	t_{PLSS} SR	50	–	–	μ s	–
Negative Load Step Settling Time	t_{NLSS} SR	100	–	–	μ s	–
External Buffer Capacitor on V_{DDC}	C_{EXT} SR	–	10	–	μ F	In addition $C = 100$ nF capacitor on each V_{DDC} pin

Positive Load Step Examples

System assumptions:

$f_{CPU} = f_{SYS}$, target frequency $f_{CPU} = 144$ MHz, main PLL $f_{VCO} = 288$ MHz, stepping done by K2 divider, t_{PLSS} between individual steps:

24 MHz - 48 MHz - 72 MHz - 96 MHz - 144 MHz (K2 steps 12 - 6 - 4 - 3 - 2)

24 MHz - 48 MHz - 96 MHz - 144 MHz (K2 steps 12 - 6 - 3 - 2)

24 MHz - 72 MHz - 144 MHz (K2 steps 12 - 4 - 2)

3.3.4 Phase Locked Loop (PLL) Characteristics

Note: These parameters are not subject to production test, but verified by design and/or characterization.

Main and USB PLL

Table 39 PLL Parameters

Parameter	Symbol	Values			Unit	Note / Test Condition
		Min.	Typ.	Max.		
Accumulated Jitter	D_p CC	–	–	±5	ns	accumulated over 300 cycles $f_{SYS} = 144$ MHz
Duty Cycle ¹⁾	D_{DC} CC	46	50	54	%	Low pulse to total period, assuming an ideal input clock source
PLL base frequency	$f_{PLLBASE}$ CC	30	–	140	MHz	–
VCO input frequency	f_{REF} CC	4	–	16	MHz	–
VCO frequency range	f_{VCO} CC	260	–	520	MHz	–
PLL lock-in time	t_L CC	–	–	400	μs	–

1) 50% for even K2 divider values, 50±(10/K2) for odd K2 divider values.

3.3.5 Internal Clock Source Characteristics

Note: These parameters are not subject to production test, but verified by design and/or characterization.

Fast Internal Clock Source

Table 40 Fast Internal Clock Parameters

Parameter	Symbol	Values			Unit	Note / Test Condition
		Min.	Typ.	Max.		
Nominal frequency	f_{OFINC} CC	–	36.5	–	MHz	not calibrated
		–	24	–	MHz	calibrated
Accuracy	Δf_{OFI} CC	-0.5	–	0.5	%	automatic calibration ¹⁾²⁾
		-15	–	15	%	factory calibration, $V_{\text{DDP}} = 3.3 \text{ V}$
		-25	–	25	%	no calibration, $V_{\text{DDP}} = 3.3 \text{ V}$
		-7	–	7	%	Variation over voltage range ³⁾ $3.13 \text{ V} \leq V_{\text{DDP}} \leq 3.63 \text{ V}$
Start-up time	t_{OFIS} CC	–	50	–	μs	–

1) Error in addition to the accuracy of the reference clock.

2) Automatic calibration compensates variations of the temperature and in the V_{DDP} supply voltage.

3) Deviations from the nominal V_{DDP} voltage induce an additional error to the uncalibrated and/or factory calibrated oscillator frequency.

Slow Internal Clock Source

Table 41 Slow Internal Clock Parameters

Parameter	Symbol	Values			Unit	Note / Test Condition
		Min.	Typ.	Max.		
Nominal frequency	f_{OSI} CC	–	32.768	–	kHz	
Accuracy	Δf_{OSI} CC	-4	–	4	%	$V_{BAT} = \text{const.}$ $0\text{ }^{\circ}\text{C} \leq T_A \leq 85\text{ }^{\circ}\text{C}$
		-5	–	5	%	$V_{BAT} = \text{const.}$ $T_A < 0\text{ }^{\circ}\text{C}$ or $T_A > 85\text{ }^{\circ}\text{C}$
		-5	–	5	%	$2.4\text{ V} \leq V_{BAT}$, $T_A = 25\text{ }^{\circ}\text{C}$
		-10	–	10	%	$1.95\text{ V} \leq V_{BAT} < 2.4\text{ V}$, $T_A = 25\text{ }^{\circ}\text{C}$
Start-up time	t_{OSIS} CC	–	50	–	μs	–

3.3.6 JTAG Interface Timing

The following parameters are applicable for communication through the JTAG debug interface. The JTAG module is fully compliant with IEEE1149.1-2000.

Note: These parameters are not subject to production test, but verified by design and/or characterization.

Note: Operating conditions apply.

Table 42 JTAG Interface Timing Parameters

Parameter	Symbol	Values			Unit	Note / Test Condition
		Min.	Typ.	Max.		
TCK clock period	t_1 SR	25	–	–	ns	–
TCK high time	t_2 SR	10	–	–	ns	–
TCK low time	t_3 SR	10	–	–	ns	–
TCK clock rise time	t_4 SR	–	–	4	ns	–
TCK clock fall time	t_5 SR	–	–	4	ns	–
TDI/TMS setup to TCK rising edge	t_6 SR	6	–	–	ns	–
TDI/TMS hold after TCK rising edge	t_7 SR	6	–	–	ns	–
TDO valid after TCK falling edge ¹⁾ (propagation delay)	t_8 CC	–	–	13	ns	$C_L = 50$ pF
		3	–	–	ns	$C_L = 20$ pF
TDO hold after TCK falling edge ¹⁾	t_{18} CC	2	–	–	ns	
TDO high imped. to valid from TCK falling edge ¹⁾²⁾	t_9 CC	–	–	14	ns	$C_L = 50$ pF
TDO valid to high imped. from TCK falling edge ¹⁾	t_{10} CC	–	–	13.5	ns	$C_L = 50$ pF

1) The falling edge on TCK is used to generate the TDO timing.

2) The setup time for TDO is given implicitly by the TCK cycle time.

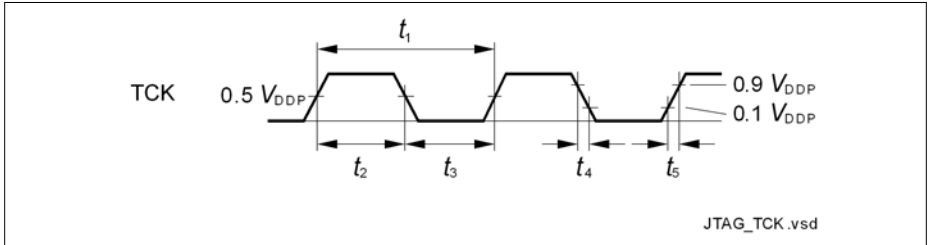

Figure 27 Test Clock Timing (TCK)

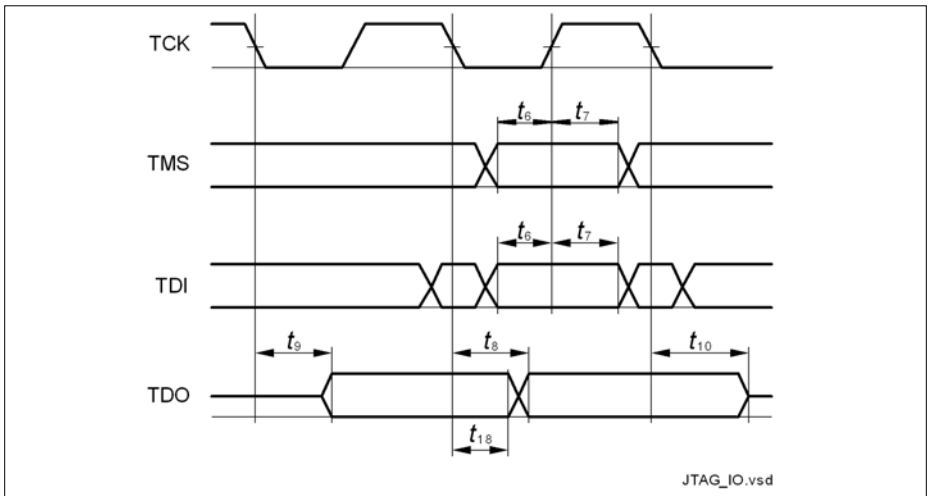

Figure 28 JTAG Timing

3.3.7 Serial Wire Debug Port (SW-DP) Timing

The following parameters are applicable for communication through the SW-DP interface.

Note: These parameters are not subject to production test, but verified by design and/or characterization.

Note: Operating conditions apply.

Table 43 SWD Interface Timing Parameters (Operating Conditions apply)

Parameter	Symbol		Values			Unit	Note / Test Condition
			Min.	Typ.	Max.		
SWDCLK clock period	t_{SC}	SR	25	–	–	ns	$C_L = 30$ pF
			40	–	–	ns	$C_L = 50$ pF
SWDCLK high time	t_1	SR	10	–	500000	ns	–
SWDCLK low time	t_2	SR	10	–	500000	ns	–
SWDIO input setup to SWDCLK rising edge	t_3	SR	6	–	–	ns	–
SWDIO input hold after SWDCLK rising edge	t_4	SR	6	–	–	ns	–
SWDIO output valid time after SWDCLK rising edge	t_5	CC	–	–	17	ns	$C_L = 50$ pF
			–	–	13	ns	$C_L = 30$ pF
SWDIO output hold time from SWDCLK rising edge	t_6	CC	3	–	–	ns	–

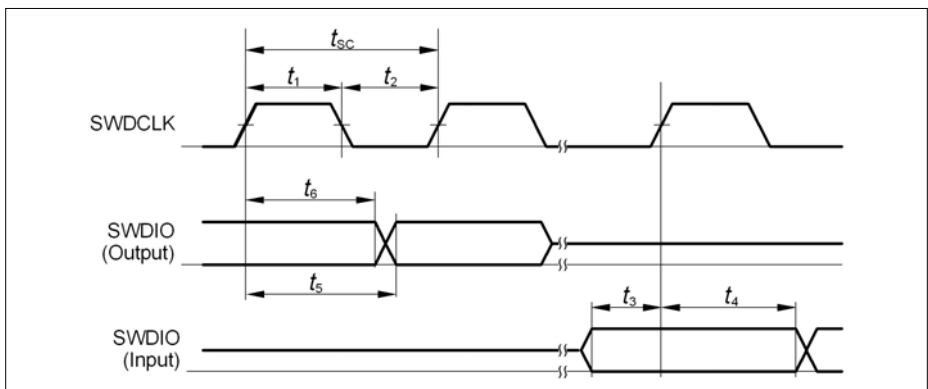

Figure 29 SWD Timing

3.3.8 Embedded Trace Macro Cell (ETM) Timing

The data timing refers to the active clock edge. The XMC4[78]00 ETM uses the half-rate clocking mode. In this mode both, the rising and falling clock edges are active clock edges.

Note: These parameters are not subject to production test, but verified by design and/or characterization.

Note: Operating conditions apply, with $C_L \leq 15$ pF.

Table 44 ETM Interface Timing Parameters

Parameter	Symbol	CC	Values			Unit	Note / Test Condition
			Min.	Typ.	Max.		
TRACECLK period	t_1	CC	13.8	–	–	ns	–
TRACECLK high time	t_2	CC	2	–	–	ns	–
TRACECLK low time	t_3	CC	2	–	–	ns	–
TRACECLK and TRACEDATA rise time	t_4	CC	–	–	3	ns	–
TRACECLK and TRACEDATA fall time	t_5	CC	–	–	3	ns	–
TRACEDATA output valid time	t_6	CC	-2	–	3	ns	–

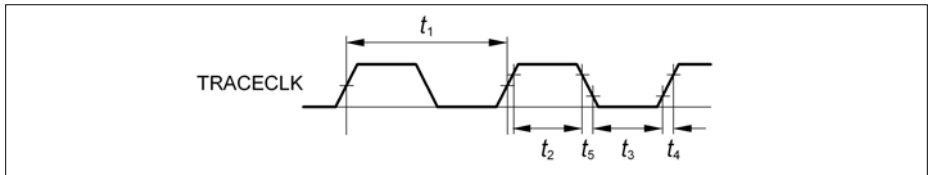

Figure 30 ETM Clock Timing

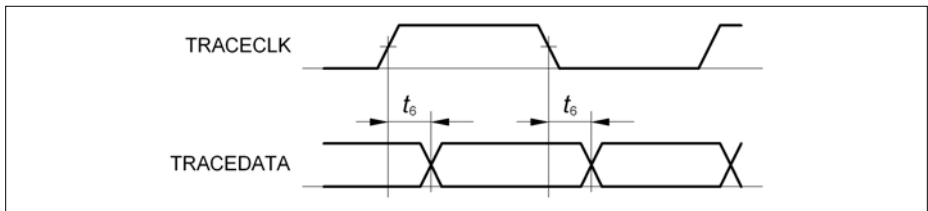

Figure 31 ETM Data Timing

3.3.9 Peripheral Timing

3.3.9.1 Delta-Sigma Demodulator Digital Interface Timing

The following parameters are applicable for the digital interface of the Delta-Sigma Demodulator (DSD).

The data timing is relative to the active clock edge. Depending on the operation mode of the connected modulator that can be the rising and falling clock edge.

Note: These parameters are not subject to production test, but verified by design and/or characterization.

Table 45 DSD Interface Timing Parameters

Parameter	Symbol	Values			Unit	Note / Test Condition
		Min.	Typ.	Max.		
MCLK period in master mode	t_1 CC	33.3	–	–	ns	$t_1 \geq 4 \times t_{\text{PERIPH}}^{1)}$
MCLK high time in master mode	t_2 CC	9	–	–	ns	$t_2 > t_{\text{PERIPH}}^{1)}$
MCLK low time in master mode	t_3 CC	9	–	–	ns	$t_3 > t_{\text{PERIPH}}^{1)}$
MCLK period in slave mode	t_1 SR	33.3	–	–	ns	$t_1 \geq 4 \times t_{\text{PERIPH}}^{1)}$
MCLK high time in slave mode	t_2 SR	t_{PERIPH}	–	–	ns	¹⁾
MCLK low time in slave mode	t_3 SR	t_{PERIPH}	–	–	ns	¹⁾
DIN input setup time to the active clock edge	t_4 SR	$t_{\text{PERIPH}} + 4$	–	–	ns	¹⁾
DIN input hold time from the active clock edge	t_5 SR	$t_{\text{PERIPH}} + 3$	–	–	ns	¹⁾

¹⁾ $t_{\text{PERIPH}} = 1 / f_{\text{PERIPH}}$

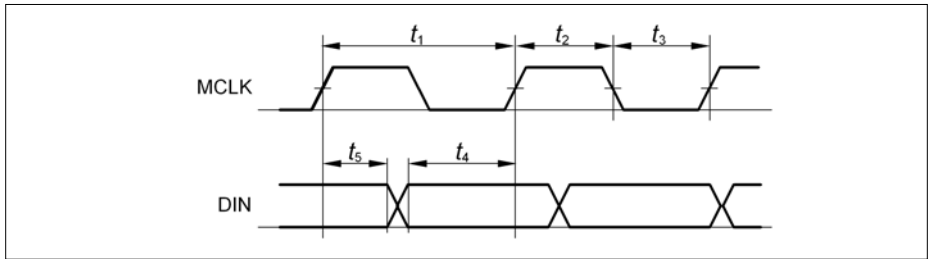

Figure 32 DSD Data Timing

3.3.9.2 Synchronous Serial Interface (USIC SSC) Timing

The following parameters are applicable for a USIC channel operated in SSC mode.

Note: These parameters are not subject to production test, but verified by design and/or characterization.

Table 46 USIC SSC Master Mode Timing

Parameter	Symbol	Values			Unit	Note / Test Condition
		Min.	Typ.	Max.		
SCLKOUT master clock period	t_{CLK} CC	33.3	–	–	ns	–
Slave select output SELO active to first SCLKOUT transmit edge	t_1 CC	$t_{PB} - 6.5^{1)}$	–	–	ns	–
Slave select output SELO inactive after last SCLKOUT receive edge	t_2 CC	$t_{PB} - 8.5^{1)}$	–	–	ns	–
Data output DOUT[3:0] valid time	t_3 CC	-6	–	8	ns	–
Receive data input DX0/DX[5:3] setup time to SCLKOUT receive edge	t_4 SR	23	–	–	ns	–
Data input DX0/DX[5:3] hold time from SCLKOUT receive edge	t_5 SR	1	–	–	ns	–

1) $t_{PB} = 1 / f_{PB}$

Table 47 USIC SSC Slave Mode Timing

Parameter	Symbol		Values			Unit	Note / Test Condition
			Min.	Typ.	Max.		
DX1 slave clock period	t_{CLK}	SR	66.6	–	–	ns	–
Select input DX2 setup to first clock input DX1 transmit edge ¹⁾	t_{10}	SR	3	–	–	ns	–
Select input DX2 hold after last clock input DX1 receive edge ¹⁾	t_{11}	SR	4	–	–	ns	–
Receive data input DX0/DX[5:3] setup time to shift clock receive edge ¹⁾	t_{12}	SR	6	–	–	ns	–
Data input DX0/DX[5:3] hold time from clock input DX1 receive edge ¹⁾	t_{13}	SR	4	–	–	ns	–
Data output DOUT[3:0] valid time	t_{14}	CC	0	–	24	ns	–

1) This input timing is valid for asynchronous input signal handling of slave select input, shift clock input, and receive data input (bits DXnCR.DSEN = 0).

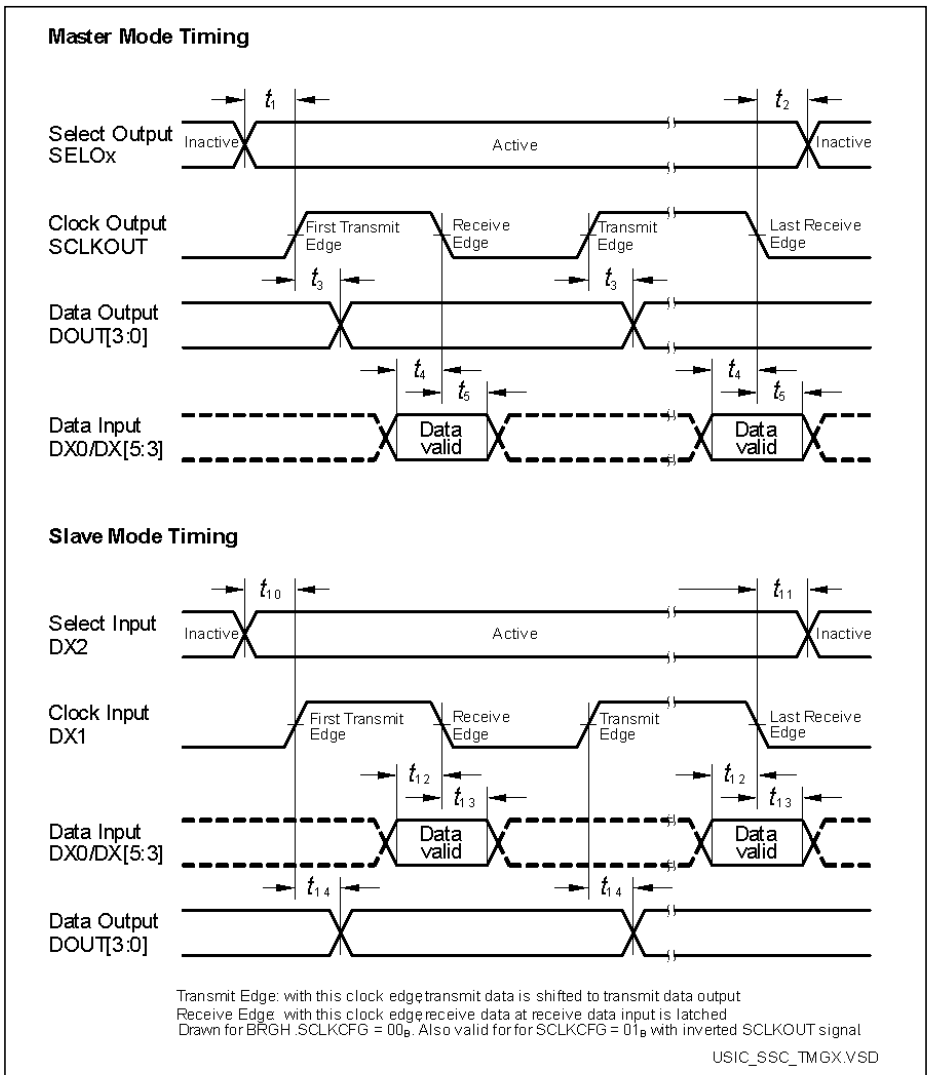

Figure 33 USIC - SSC Master/Slave Mode Timing

Note: This timing diagram shows a standard configuration, for which the slave select signal is low-active, and the serial clock signal is not shifted and not inverted.

3.3.9.3 Inter-IC (IIC) Interface Timing

The following parameters are applicable for a USIC channel operated in IIC mode.

Note: These parameters are not subject to production test, but verified by design and/or characterization.

Table 48 USIC IIC Standard Mode Timing¹⁾

Parameter	Symbol	Values			Unit	Note / Test Condition
		Min.	Typ.	Max.		
Fall time of both SDA and SCL	t_1 CC/SR	–	–	300	ns	–
Rise time of both SDA and SCL	t_2 CC/SR	–	–	1000	ns	–
Data hold time	t_3 CC/SR	0	–	–	μs	–
Data set-up time	t_4 CC/SR	250	–	–	ns	–
LOW period of SCL clock	t_5 CC/SR	4.7	–	–	μs	–
HIGH period of SCL clock	t_6 CC/SR	4.0	–	–	μs	–
Hold time for (repeated) START condition	t_7 CC/SR	4.0	–	–	μs	–
Set-up time for repeated START condition	t_8 CC/SR	4.7	–	–	μs	–
Set-up time for STOP condition	t_9 CC/SR	4.0	–	–	μs	–
Bus free time between a STOP and START condition	t_{10} CC/SR	4.7	–	–	μs	–
Capacitive load for each bus line	C_b SR	–	–	400	pF	–

1) Due to the wired-AND configuration of an IIC bus system, the port drivers of the SCL and SDA signal lines need to operate in open-drain mode. The high level on these lines must be held by an external pull-up device, approximately 10 kOhm for operation at 100 kbit/s, approximately 2 kOhm for operation at 400 kbit/s.

Table 49 USIC IIC Fast Mode Timing¹⁾

Parameter	Symbol	Values			Unit	Note / Test Condition
		Min.	Typ.	Max.		
Fall time of both SDA and SCL	t_1 CC/SR	20 + $0.1 \cdot C_b$ ²⁾	–	300	ns	–
Rise time of both SDA and SCL	t_2 CC/SR	20 + $0.1 \cdot C_b$ ²⁾	–	300	ns	–
Data hold time	t_3 CC/SR	0	–	–	μs	–
Data set-up time	t_4 CC/SR	100	–	–	ns	–
LOW period of SCL clock	t_5 CC/SR	1.3	–	–	μs	–
HIGH period of SCL clock	t_6 CC/SR	0.6	–	–	μs	–
Hold time for (repeated) START condition	t_7 CC/SR	0.6	–	–	μs	–
Set-up time for repeated START condition	t_8 CC/SR	0.6	–	–	μs	–
Set-up time for STOP condition	t_9 CC/SR	0.6	–	–	μs	–
Bus free time between a STOP and START condition	t_{10} CC/SR	1.3	–	–	μs	–
Capacitive load for each bus line	C_b SR	–	–	400	pF	–

1) Due to the wired-AND configuration of an IIC bus system, the port drivers of the SCL and SDA signal lines need to operate in open-drain mode. The high level on these lines must be held by an external pull-up device, approximately 10 kΩ for operation at 100 kbit/s, approximately 2 kΩ for operation at 400 kbit/s.

2) C_b refers to the total capacitance of one bus line in pF.

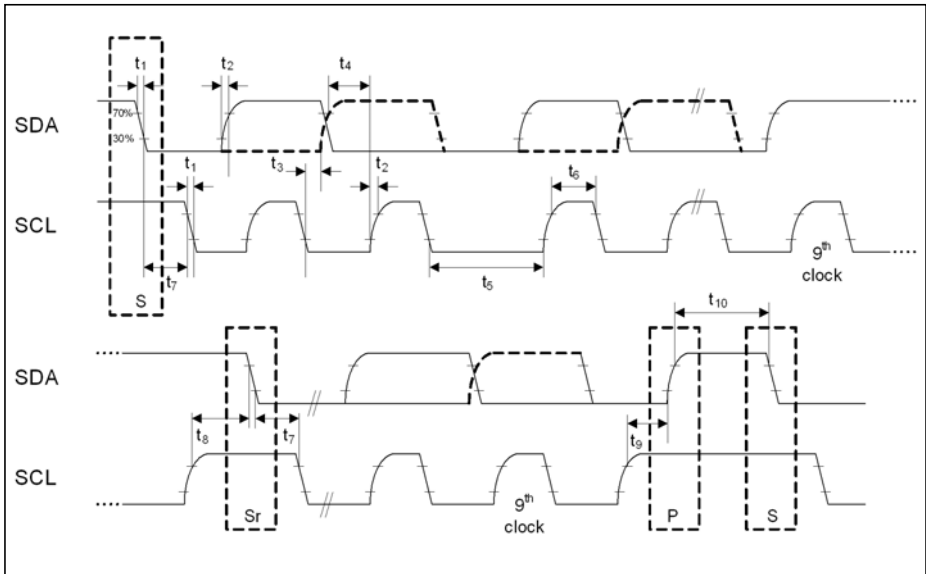

Figure 34 USIC IIC Stand and Fast Mode Timing

3.3.9.4 Inter-IC Sound (IIS) Interface Timing

The following parameters are applicable for a USIC channel operated in IIS mode.

Note: These parameters are not subject to production test, but verified by design and/or characterization.

Table 50 USIC IIS Master Transmitter Timing

Parameter	Symbol	Values			Unit	Note / Test Condition
		Min.	Typ.	Max.		
Clock period	t_1 CC	33.3	–	–	ns	–
Clock high time	t_2 CC	0.35 x t_{1min}	–	–	ns	–
Clock low time	t_3 CC	0.35 x t_{1min}	–	–	ns	–
Hold time	t_4 CC	0	–	–	ns	–
Clock rise time	t_5 CC	–	–	0.15 x t_{1min}	ns	–

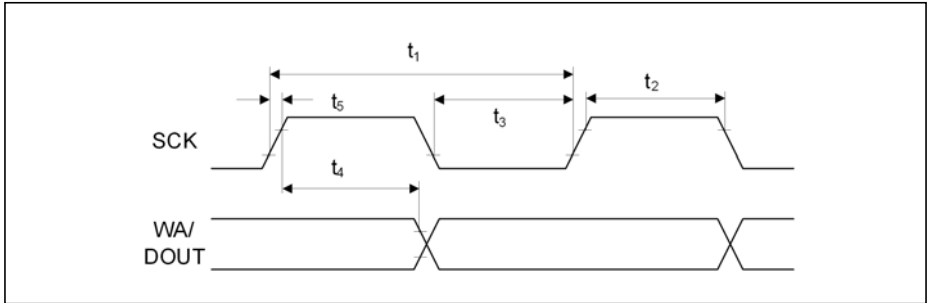

Figure 35 USIC IIS Master Transmitter Timing

Table 51 USIC IIS Slave Receiver Timing

Parameter	Symbol	Values			Unit	Note / Test Condition
		Min.	Typ.	Max.		
Clock period	t_6 SR	66.6	–	–	ns	–
Clock high time	t_7 SR	0.35 x t_{6min}	–	–	ns	–
Clock low time	t_8 SR	0.35 x t_{6min}	–	–	ns	–
Set-up time	t_9 SR	0.2 x t_{6min}	–	–	ns	–
Hold time	t_{10} SR	0	–	–	ns	–

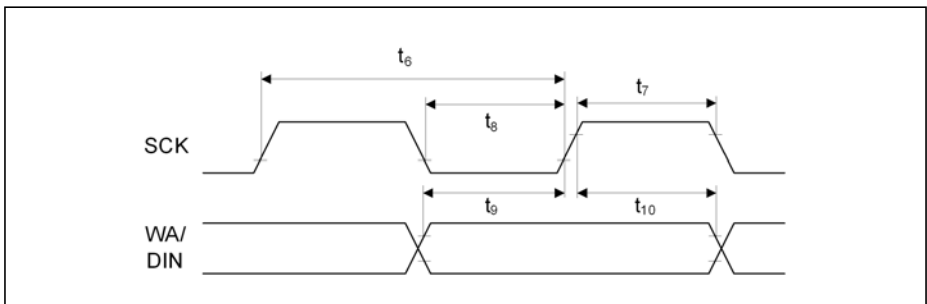

Figure 36 USIC IIS Slave Receiver Timing

3.3.9.5 SDMMC Interface Timing

Note: These parameters are not subject to production test, but verified by design and/or characterization.

Note: Operating Conditions apply, total external capacitive load $C_L = 40$ pF.

AC Timing Specifications (Full-Speed Mode)

Table 52 SDMMC Timing for Full-Speed Mode

Parameter	Symbol	Values	Unit		Note/ Test Condition
			Min.	Max.	
Clock frequency in full speed transfer mode ($1/t_{pp}$)	f_{pp} CC	0	24	MHz	–
Clock cycle in full speed transfer mode	t_{pp} CC	40	–	ns	–
Clock low time	t_{WL} CC	10	–	ns	–
Clock high time	t_{WH} CC	10	–	ns	–
Clock rise time	t_{TLH} CC	–	10	ns	–
Clock fall time	t_{THL} CC	–	10	ns	–
Inputs setup to clock rising edge	t_{ISU_F} SR	2	–	ns	–
Inputs hold after clock rising edge	t_{IH_F} SR	2	–	ns	–
Outputs valid time in full speed mode	t_{ODLY_F} CC	–	10	ns	–
Outputs hold time in full speed mode	t_{OH_F} CC	0	–	ns	–

Table 53 SD Card Bus Timing for Full-Speed Mode¹⁾

Parameter	Symbol	Values		Unit	Note/ Test Condition
		Min.	Max.		
SD card input setup time	t_{ISU}	5	–	ns	–
SD card input hold time	t_{IH}	5	–	ns	–
SD card output valid time	t_{ODLY}	–	14	ns	–
SD card output hold time	t_{OH}	0	–	ns	–

1) Reference card timing values for calculation examples. Not subject to production test and not characterized.

Full-Speed Output Path (Write)

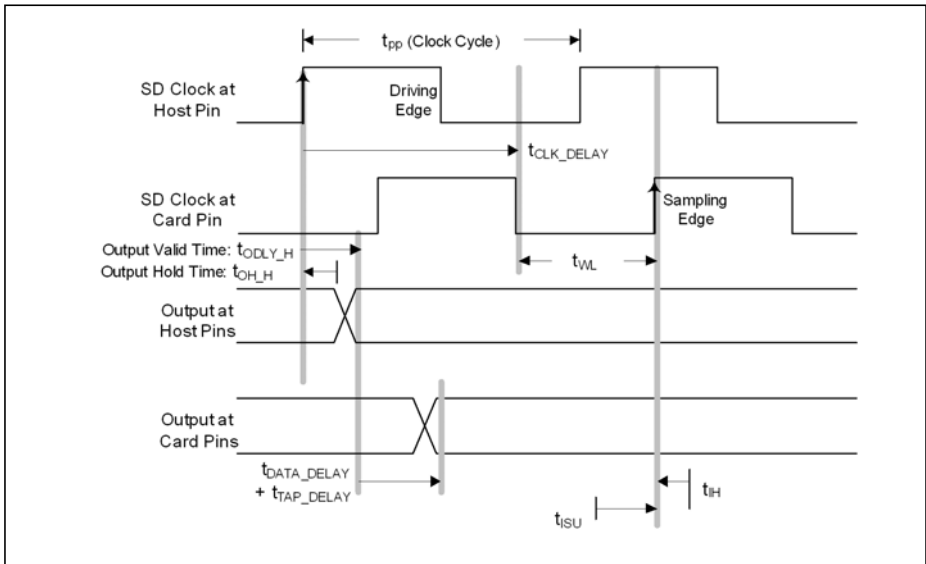

Figure 37 Full-Speed Output Path

Full-Speed Write Meeting Setup (Maximum Delay)

The following equations show how to calculate the allowed skew range between the SD_CLK and SD_DAT/CMD signals on the PCB.

No clock delay:

$$t_{ODLY_F} + t_{DATA_DELAY} + t_{TAP_DELAY} + t_{ISU} < t_{WL} \quad (1)$$

With clock delay:

$$t_{ODLY_F} + t_{DATA_DELAY} + t_{TAP_DELAY} + t_{ISU} < t_{WL} + t_{CLK_DELAY} \quad (2)$$

$$t_{DATA_DELAY} + t_{TAP_DELAY} + t_{WL} < t_{PP} + t_{CLK_DELAY} - t_{ISU} - t_{ODLY_F} \quad (3)$$

$$t_{DATA_DELAY} + t_{TAP_DELAY} + 20 < 40 + t_{CLK_DELAY} - 5 - 10$$

$$t_{DATA_DELAY} < 5 + t_{CLK_DELAY} - t_{TAP_DELAY}$$

The data can be delayed versus clock up to 5 ns in ideal case of $t_{WL} = 20$ ns.

Full-Speed Write Meeting Hold (Minimum Delay)

The following equations show how to calculate the allowed skew range between the SD_CLK and SD_DAT/CMD signals on the PCB.

$$t_{CLK_DELAY} < t_{WL} + t_{OH_F} + t_{DATA_DELAY} + t_{TAP_DELAY} - t_{IH} \quad (4)$$

$$t_{CLK_DELAY} < 20 + t_{DATA_DELAY} + t_{TAP_DELAY} - 5$$

$$t_{DATA_DELAY} < 15 + t_{CLK_DELAY} + t_{TAP_DELAY}$$

The clock can be delayed versus data up to 18.2 ns (external delay line) in ideal case of $t_{WL} = 20$ ns, with maximum $t_{TAP_DELAY} = 3.2$ ns programmed.

Full-Speed Input Path (Read)

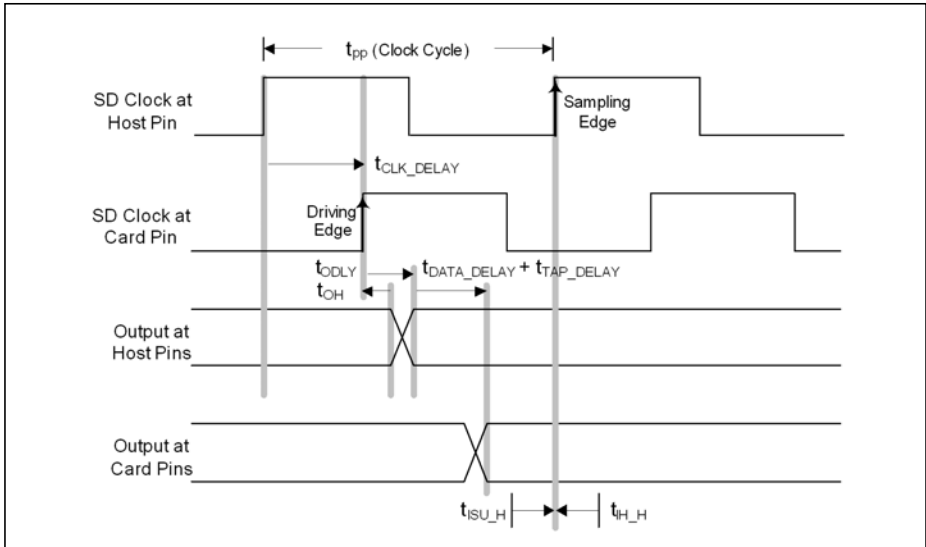

Figure 38 Full-Speed Input Path

Full-Speed Read Meeting Setup (Maximum Delay)

The following equations show how to calculate the allowed combined propagation delay range of the SD_CLK and SD_DAT/CMD signals on the PCB.

(5)

$$t_{CLK_DELAY} + t_{DATA_DELAY} + t_{TAP_DELAY} + t_{ODLY} + t_{ISU_F} < 0.5 \times t_{pp}$$

$$t_{CLK_DELAY} + t_{DATA_DELAY} < 0.5 \times t_{pp} - t_{ODLY} - t_{ISU_F} - t_{TAP_DELAY}$$

$$t_{CLK_DELAY} + t_{DATA_DELAY} < 20 - 14 - 2 - t_{TAP_DELAY}$$

$$t_{CLK_DELAY} + t_{DATA_DELAY} < 4 - t_{TAP_DELAY}$$

The data + clock delay can be up to 4 ns for a 40 ns clock cycle.

Electrical Parameters
Full-Speed Read Meeting Hold (Minimum Delay)

The following equations show how to calculate the allowed combined propagation delay range of the SD_CLK and SD_DAT/CMD signals on the PCB.

(6)

$$t_{\text{CLK_DELAY}} + t_{\text{OH}} + t_{\text{DATA_DELAY}} + t_{\text{TAP_DELAY}} > t_{\text{IH_F}}$$

$$t_{\text{CLK_DELAY}} + t_{\text{DATA_DELAY}} > t_{\text{IH_F}} - t_{\text{OH}} - t_{\text{TAP_DELAY}}$$

$$t_{\text{CLK_DELAY}} + t_{\text{DATA_DELAY}} > 2 - t_{\text{TAP_DELAY}}$$

The data + clock delay must be greater than 2 ns if $t_{\text{TAP_DELAY}}$ is not used.

If the $t_{\text{TAP_DELAY}}$ is programmed to at least 2 ns, the data + clock delay must be greater than 0 ns (or less). This is always fulfilled.

AC Timing Specifications (High-Speed Mode)
Table 54 SDMMC Timing for High-Speed Mode

Parameter	Symbol		Values		Unit	Note/ Test Condition
			Min.	Max.		
Clock frequency in high speed transfer mode ($1/t_{\text{pp}}$)	f_{pp}	CC	0	48	MHz	—
Clock cycle in high speed transfer mode	t_{pp}	CC	20	—	ns	—
Clock low time	t_{WL}	CC	7	—	ns	—
Clock high time	t_{WH}	CC	7	—	ns	—
Clock rise time	t_{TLH}	CC	—	3	ns	—
Clock fall time	t_{THL}	CC	—	3	ns	—
Inputs setup to clock rising edge	$t_{\text{ISU_H}}$	SR	2	—	ns	—
Inputs hold after clock rising edge	$t_{\text{IH_H}}$	SR	2	—	ns	—
Outputs valid time in high speed mode	$t_{\text{ODLY_H}}$	CC	—	14	ns	—
Outputs hold time in high speed mode	$t_{\text{OH_H}}$	CC	2	—	ns	—

Table 55 SD Card Bus Timing for High-Speed Mode¹⁾

Parameter	Symbol	Values		Unit	Note/ Test Condition
		Min.	Max.		
SD card input setup time	t_{ISU}	6	–	ns	–
SD card input hold time	t_{IH}	2	–	ns	–
SD card output valid time	t_{ODLY}	–	14	ns	–
SD card output hold time	t_{OH}	2.5	–	ns	–

1) Reference card timing values for calculation examples. Not subject to production test and not characterized.

High-Speed Output Path (Write)

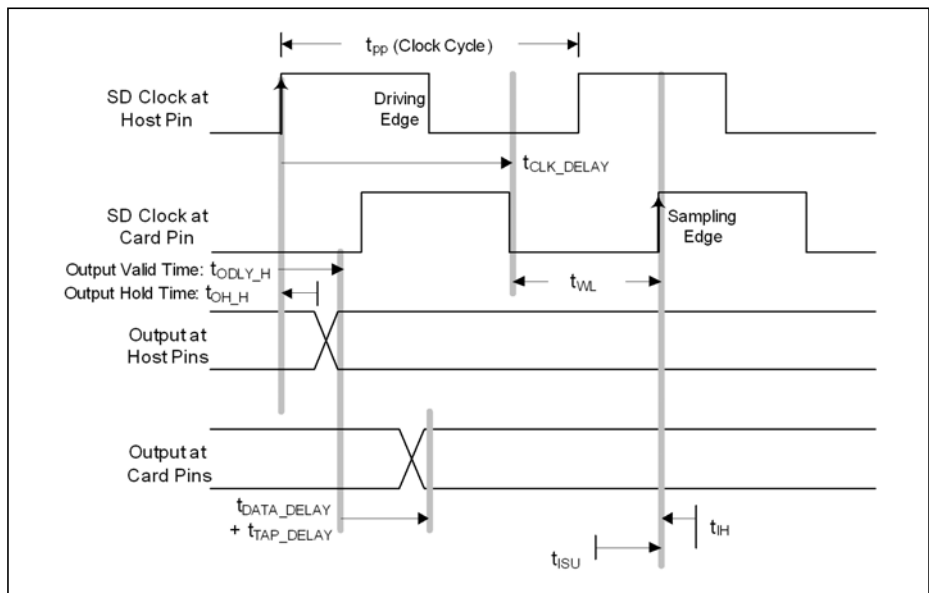

Figure 39 High-Speed Output Path

High-Speed Write Meeting Setup (Maximum Delay)

The following equations show how to calculate the allowed skew between the SD_CLK and SD_DAT/CMD signals on the PCB.

Electrical Parameters

No clock delay:

(7)

$$t_{ODLY_H} + t_{DATA_DELAY} + t_{TAP_DELAY} + t_{ISU} < t_{WL}$$

With clock delay:

(8)

$$t_{ODLY_H} + t_{DATA_DELAY} + t_{TAP_DELAY} + t_{ISU} < t_{WL} + t_{CLK_DELAY}$$

(9)

$$t_{DATA_DELAY} + t_{TAP_DELAY} - t_{CLK_DELAY} < t_{WL} - t_{ISU} - t_{ODLY_H}$$

$$t_{DATA_DELAY} - t_{CLK_DELAY} < t_{WL} - t_{ISU} - t_{ODLY_H} - t_{TAP_DELAY}$$

$$t_{DATA_DELAY} - t_{CLK_DELAY} < 10 - 6 - 14 - t_{TAP_DELAY}$$

$$t_{DATA_DELAY} - t_{CLK_DELAY} < -10 - t_{TAP_DELAY}$$

The data delay is less than the clock delay by at least 10 ns in the ideal case where $t_{WL} = 10$ ns.

High-Speed Write Meeting Hold (Minimum Delay)

The following equations show how to calculate the allowed skew range between the SD_CLK and SD_DAT/CMD signals on the PCB.

(10)

$$t_{CLK_DELAY} < t_{WL} + t_{OH_H} + t_{DATA_DELAY} + t_{TAP_DELAY} - t_{IH}$$

$$t_{CLK_DELAY} - t_{DATA_DELAY} < t_{WL} + t_{OH_H} + t_{TAP_DELAY} - t_{IH}$$

$$t_{CLK_DELAY} - t_{DATA_DELAY} < 10 + 2 + t_{TAP_DELAY} - 2$$

$$t_{CLK_DELAY} - t_{DATA_DELAY} < 10 + t_{TAP_DELAY}$$

The clock can be delayed versus data up to 13.2 ns (external delay line) in ideal case of $t_{WL} = 10$ ns, with maximum $t_{TAP_DELAY} = 3.2$ ns programmed.

High-Speed Input Path (Read)

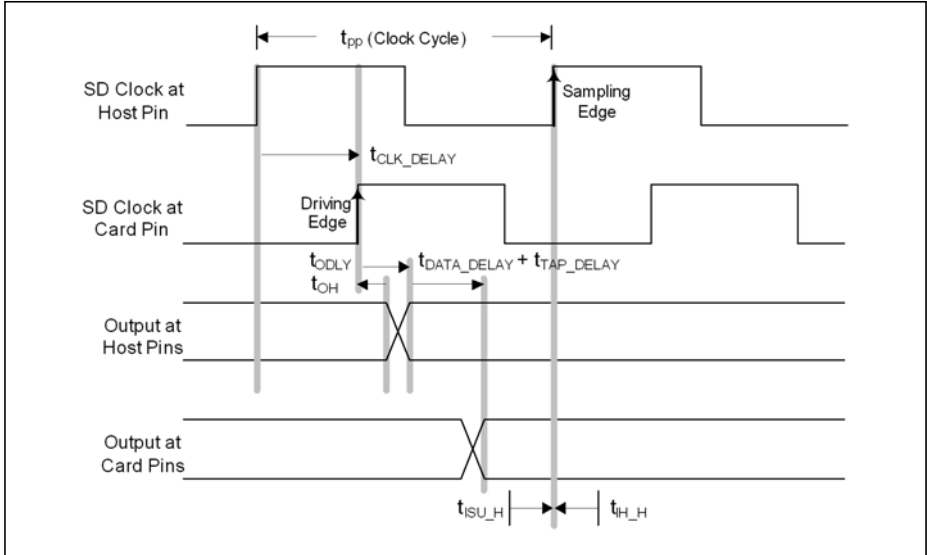

Figure 40 High-Speed Input Path

High-Speed Read Meeting Setup (Maximum Delay)

The following equations show how to calculate the allowed combined propagation delay range of the SD_CLK and SD_DAT/CMD signals on the PCB.

(11)

$$t_{CLK_DELAY} + t_{DATA_DELAY} + t_{TAP_DELAY} + t_{ODLY} + t_{ISU_H} < t_{pp}$$

$$t_{CLK_DELAY} + t_{DATA_DELAY} < t_{pp} - t_{ODLY} - t_{ISU_H} - t_{TAP_DELAY}$$

$$t_{CLK_DELAY} + t_{DATA_DELAY} < 20 - 14 - 2 - t_{TAP_DELAY}$$

$$t_{CLK_DELAY} + t_{DATA_DELAY} < 4 - t_{TAP_DELAY}$$

The data + clock delay can be up to 4 ns for a 20 ns clock cycle.

High-Speed Read Meeting Hold (Minimum Delay)

The following equations show how to calculate the allowed combined propagation delay range of the SD_CLK and SD_DAT/CMD signals on the PCB.

(12)

$$t_{\text{CLK_DELAY}} + t_{\text{OH}} + t_{\text{DATA_DELAY}} + t_{\text{TAP_DELAY}} > t_{\text{IH_H}}$$

$$t_{\text{CLK_DELAY}} + t_{\text{DATA_DELAY}} > t_{\text{IH_H}} - t_{\text{OH}} - t_{\text{TAP_DELAY}}$$

$$t_{\text{CLK_DELAY}} + t_{\text{DATA_DELAY}} > 2 - 2.5 - t_{\text{TAP_DELAY}}$$

$$t_{\text{CLK_DELAY}} + t_{\text{DATA_DELAY}} > -0.5 - t_{\text{TAP_DELAY}}$$

The data + clock delay must be greater than -0.5 ns for a 20 ns clock cycle. This is always fulfilled.

3.3.10 EBU Timing

Note: These parameters are not subject to production test, but verified by design and/or characterization.

Note: Operating Conditions apply, with Class A2 pins and $C_L = 16$ pF.

3.3.10.1 EBU Asynchronous Timing

Note: For each timing, the accumulated PLL jitter must be added separately.

Table 56 Common Timing Parameters for all Asynchronous Timings

Parameter	Sym bol	Limit Values		Unit	Edge Setting	
		Min.	Max.			
Pulse width deviation from the ideal programmed width due to the A2 pad asymmetry, strong driver mode, rise delay - fall delay. $C_L = 16$ pF.	CC	t_a	-1	1.5	ns	sharp
			-2	1		medium
AD(24:16) output delay	CC	t_{13}	-5.5	2	-	-
AD(24:16) output delay	CC	t_{14}	-5.5	2		-

Read Timing

s

Table 57 Asynchronous Read Timing, Multiplexed and Demultiplexed

Parameter		Symbol	Limit Values		Unit	
			Min.	Max.		
A(24:16) output delay	to \overline{RD} rising edge, deviation from the ideal programmed value.	CC	t_0	-2.5	2.5	ns
A(24:16) output delay		CC	t_1	-2.5	2.5	
\overline{CS} rising edge		CC	t_2	-2	2.5	
\overline{ADV} rising edge		CC	t_3	-1.5	4.5	
\overline{BC} rising edge		CC	t_4	-2.5	2.5	
\overline{WAIT} input setup		SR	t_5	12	–	
\overline{WAIT} input hold		SR	t_6	0	–	
Data input setup		SR	t_7	12	–	
Data input hold		SR	t_8	0	–	
RD / \overline{WR} output delay		CC	t_9	-2.5	1.5	

Multiplexed Read Timing

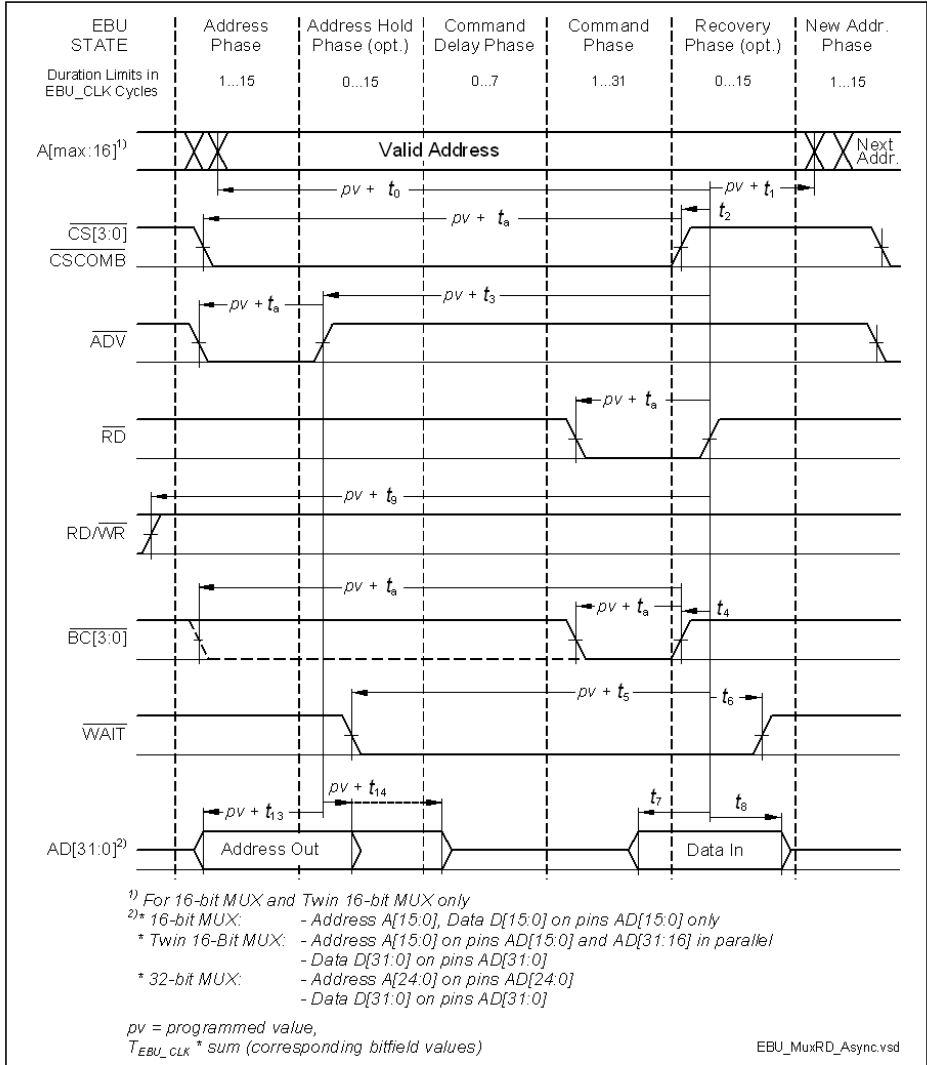

Figure 41 Multiplexed Read Access

Demultiplexed Read Timing

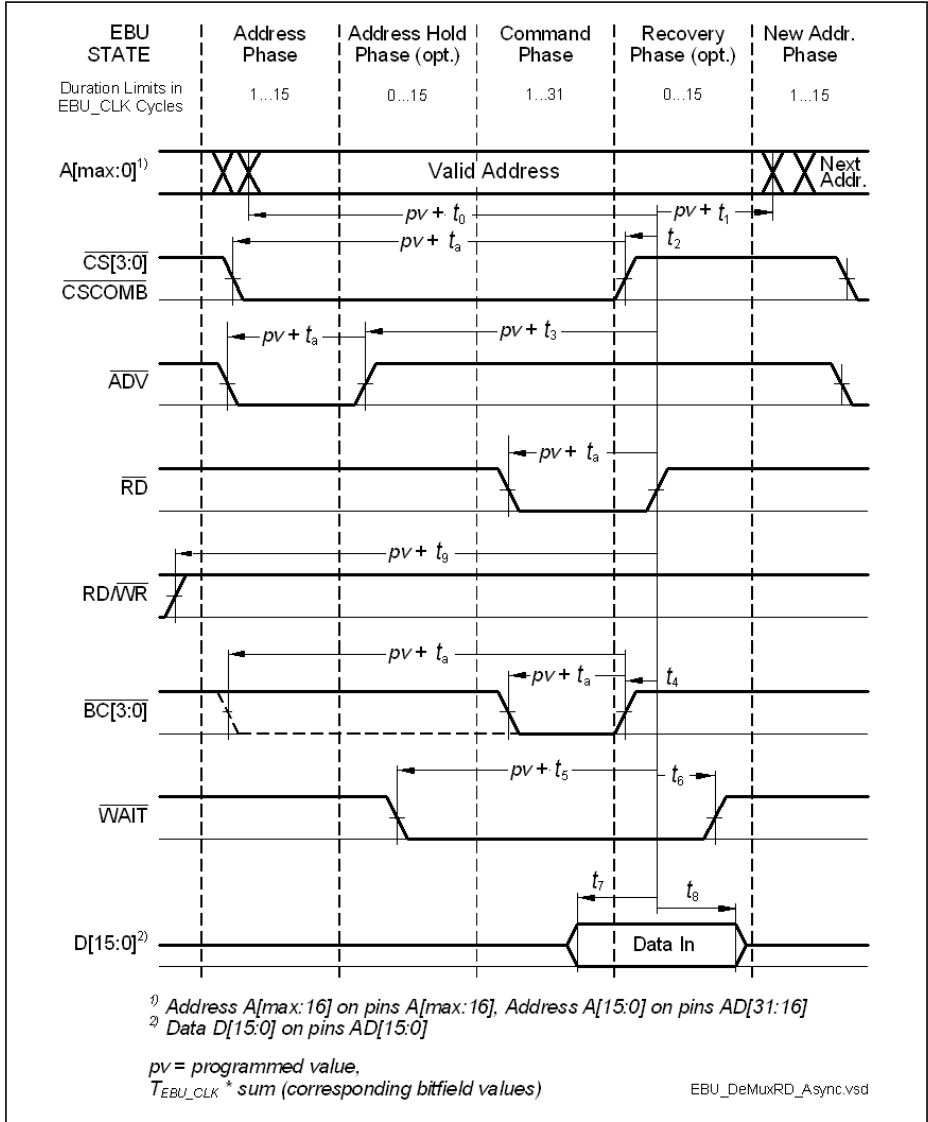

Figure 42 Demultiplexed Read Access

Write Timing

Table 58 Asynchronous Write Timing, Multiplexed and Demultiplexed

Parameter		Symbol	Limit Values		Unit	
			Min.	Max.		
A(24:0) output delay	to RD/ \overline{WR} rising edge, deviation from the ideal programmed value.	CC	t_{30}	-2.5	2.5	ns
A(24:0) output delay		CC	t_{31}	-2.5	2.5	
\overline{CS} rising edge		CC	t_{32}	-2	2	
\overline{ADV} rising edge		CC	t_{33}	-2	4.5	
\overline{BC} rising edge		CC	t_{34}	-2.5	2	
\overline{WAIT} input setup		SR	t_{35}	12	–	
\overline{WAIT} input hold		SR	t_{36}	0	–	
Data output delay		CC	t_{37}	-5.5	2	
Data output delay		CC	t_{38}	-5.5	2	
RD / \overline{WR} output delay		CC	t_{39}	-2.5	1.5	

Multiplexed Write Timing

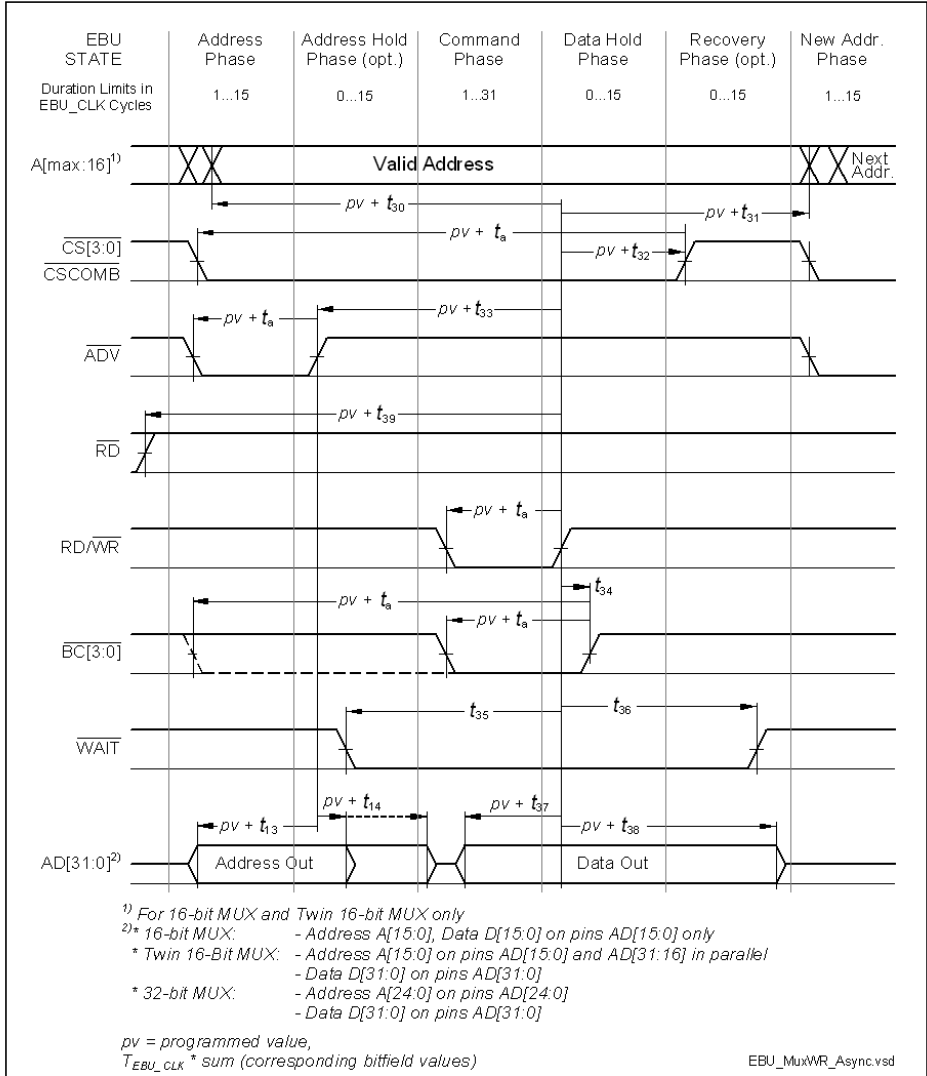

Figure 43 Multiplexed Write Access

Demultiplexed Write Timing

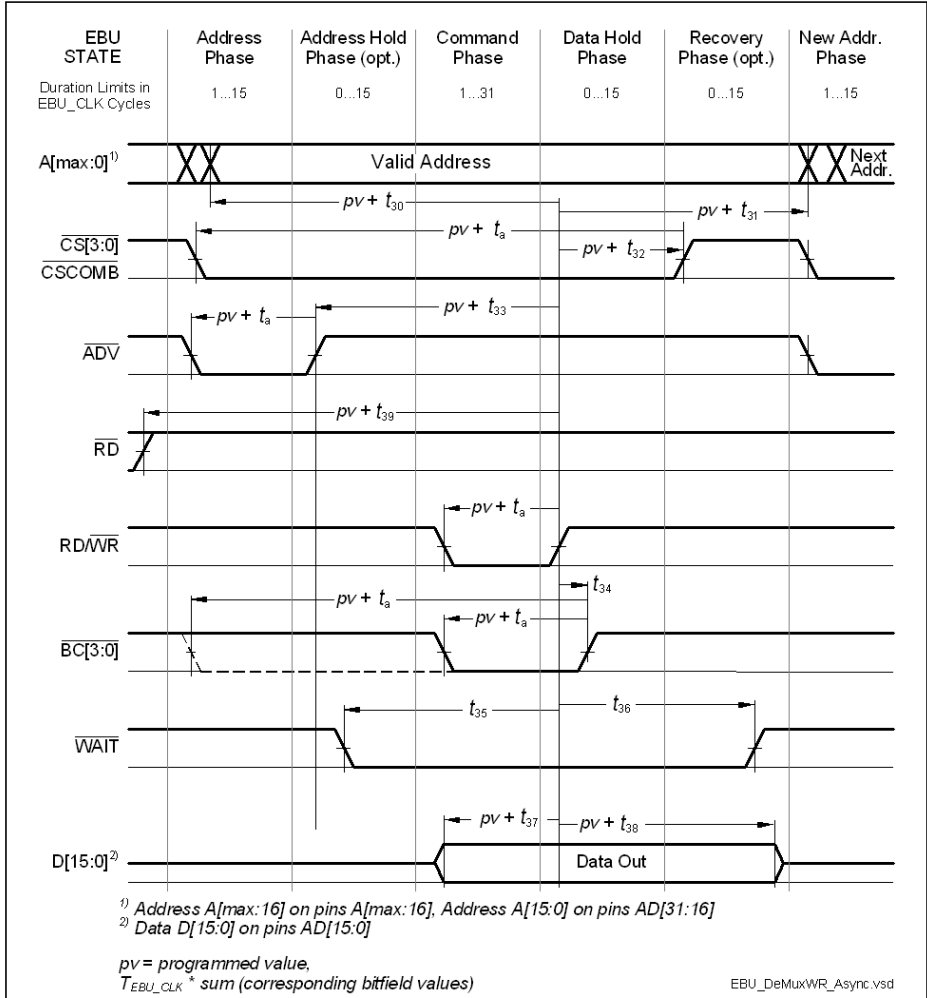

Figure 44 Demultiplexed Write Access

3.3.10.2 EBU Burst Mode Access Timing

Note: These parameters are not subject to production test, but verified by design and/or characterization.

Note: Operating Conditions apply, with Class A2 pins and $C_L = 16$ pF.

Table 59 EBU Burst Mode Read / Write Access Timing Parameters

Parameter	Symbol		Values			Unit	Note / Test Condition
			Min.	Typ.	Max.		
Output delay from BFCLKO rising edge	t_{10}	CC	-2	–	2	ns	–
\overline{RD} and $\overline{RD}/\overline{WR}$ active/inactive after BFCLKO active edge ¹⁾	t_{12}	CC	-2	–	2	ns	–
\overline{CSx} output delay from BFCLKO active edge ¹⁾	t_{21}	CC	-2.5	–	1.5	ns	–
\overline{ADV} active/inactive after BFCLKO active edge ²⁾	t_{22}	CC	-2	–	2	ns	–
\overline{BAA} active/inactive after BFCLKO active edge ²⁾	t_{22a}	CC	-2.5	–	1.5	ns	–
Data setup to BFCLKI rising edge ³⁾	t_{23}	SR	3	–	–	ns	–
Data hold from BFCLKI rising edge ³⁾	t_{24}	SR	0	–	–	ns	–
\overline{WAIT} setup (low or high) to BFCLKI rising edge ³⁾	t_{25}	SR	3	–	–	ns	–
\overline{WAIT} hold (low or high) from BFCLKI rising edge ³⁾	t_{26}	SR	0	–	–	ns	–

1) An active edge can be a rising or falling edge, depending on the settings of bits BFCON.EBSE / ECSE and the clock divider ratio.

Negative minimum values for these parameters mean that the last data read during a burst may be corrupted. However, with clock feedback enabled, this value is an oversampling not required for the internal bus transaction, and will be discarded.

2) This parameter is valid for BUSCONx.EBSE = 1 and BUSAPx.EXTCLK = 00_B.

For BUSCONx.EBSE = 1 and other values of BUSAPx.EXTCLK, ADV and BAA will be delayed by 1/2 of the internal bus clock period $T_{CPU} = 1 / f_{CPU}$.

For BUSCONx. EBSE = 0 and BUSAPx.EXTCLK = 11_B, add 2 internal bus clock periods.

For BUSCONx. EBSE = 0 and other values of BUSAPx.EXTCLK, add 1 internal bus clock period.

Electrical Parameters

3) If the clock feedback is not enabled, the input signals are latched using the internal clock in the same way as for asynchronous access. Thus, t_5 , t_6 , t_7 and t_8 from the asynchronous timing apply.

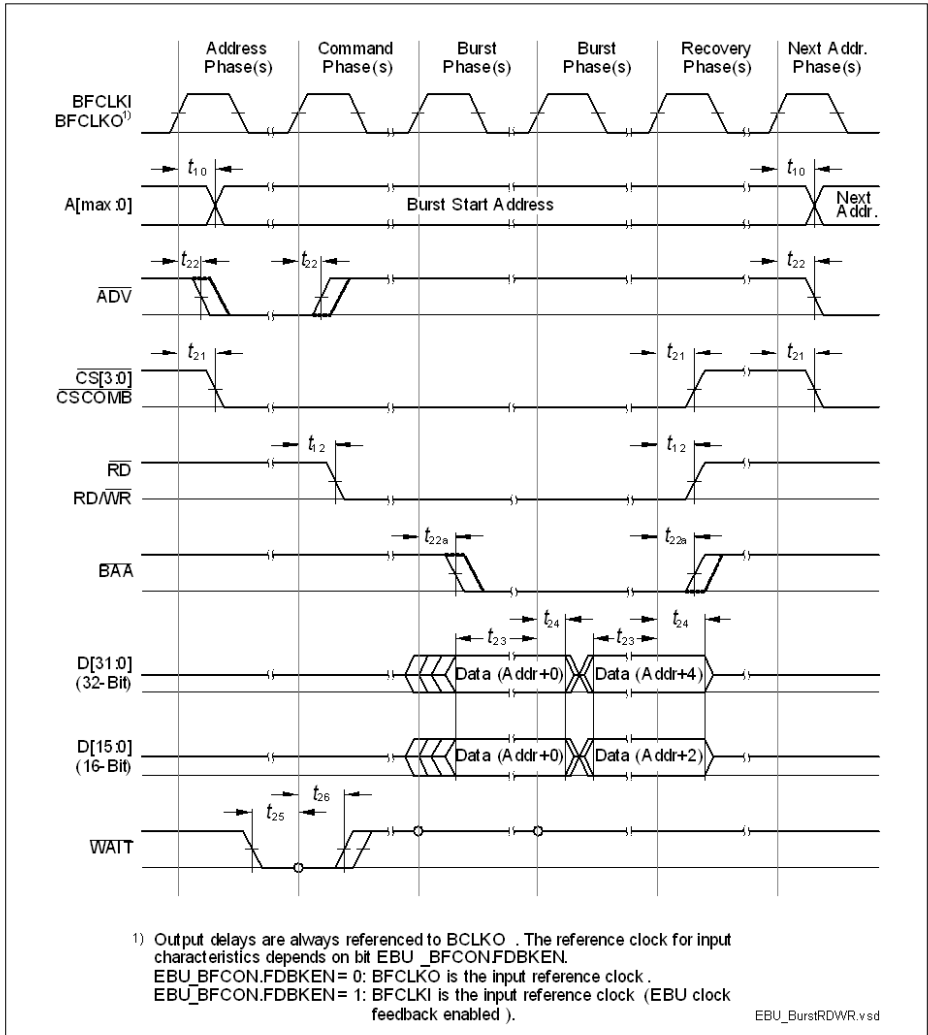

Figure 45 EBU Burst Mode Read / Write Access Timing

3.3.10.3 EBU Arbitration Signal Timing

Note: These parameters are not subject to production test, but verified by design and/or characterization.

Note: Operating Conditions apply.

Table 60 EBU Arbitration Signal Timing Parameters

Parameter	Symbol		Values			Unit	Note / Test Condition
			Min.	Typ.	Max.		
Output delay from BFCLKO rising edge	t_1	CC	–	–	16	ns	$C_L = 50 \text{ pF}$
Data setup to BFCLKO falling edge	t_2	SR	11	–	–	ns	–
Data hold from BFCLKO falling edge	t_3	SR	2	–	–	ns	–

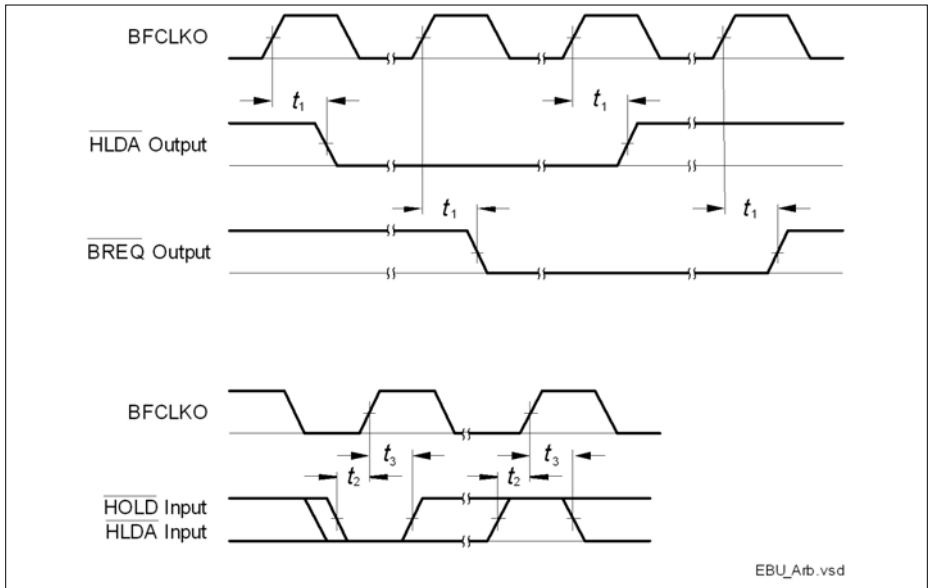

Figure 46 EBU Arbitration Signal Timing

3.3.10.4 EBU SDRAM Access Timing

Note: These parameters are not subject to production test, but verified by design and/or characterization.

Note: Operating Conditions apply, with Class A2 pins and $C_L = 16$ pF.

Note: With $EBU_CLC.SYNC = 1_B$ frequency must be limited to $f_{CPU} = 120$ MHz.

Table 61 EBU SDRAM Access SDCLKO Signal Timing Parameters

Parameter	Symbol		Values			Unit	Note / Test Condition
			Min.	Typ.	Max.		
SDCLKO period	t_1	CC	12.5	–	–	ns	–
SDCLKO high time	t_2	SR	5.5	–	–	ns	–
SDCLKO low time	t_3	SR	3.75	–	–	ns	–
SDCLKO rise time	t_4	SR	–	–	3.0	ns	–
SDCLKO fall time	t_5	SR	–	–	3.0	ns	–

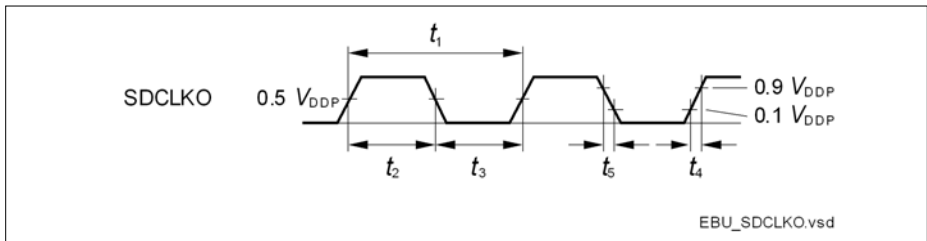

Figure 47 EBU SDRAM Access CLKOUT Timing

Table 62 EBU SDRAM Access Signal Timing Parameters

Parameter		Symbol	Limit Values		Unit
			Min.	Max.	
A(15:0) output valid	from SDCLKO low-to-high transition	CC t_6	–	9	ns
A(15:0) output hold		CC t_7	3	–	
$\overline{\text{CS}}(3:0)$ low		CC t_8	–	9	
$\overline{\text{CS}}(3:0)$ high		CC t_9	3	–	
$\overline{\text{RAS}}$ low		CC t_{10}	–	9	
$\overline{\text{RAS}}$ high		SR t_{11}	3	–	
$\overline{\text{CAS}}$ low		SR t_{12}	–	9	
$\overline{\text{CAS}}$ high		CC t_{13}	3	–	
$\overline{\text{RD}}/\overline{\text{WR}}$ low		CC t_{14}	–	9	
$\overline{\text{RD}}/\overline{\text{WR}}$ high		CC t_{15}	3	–	
$\overline{\text{BC}}(3:0)$ low		CC t_{16}	–	9	
$\overline{\text{BC}}(3:0)$ high		CC t_{17}	3	–	
D(15:0) output valid		CC t_{18}	–	9	
D(15:0) output hold		CC t_{19}	3	–	
CKE output valid ¹⁾		CC t_{22}	–	7	
CKE output hold ¹⁾		CC t_{23}	2	–	
D(15:0) input hold		SR t_{21}	3	–	
D(15:0) input setup to SDCLKO low-to-high transition	SR t_{20}	4	–		

1) Not depicted in the read and write access timing figures below.

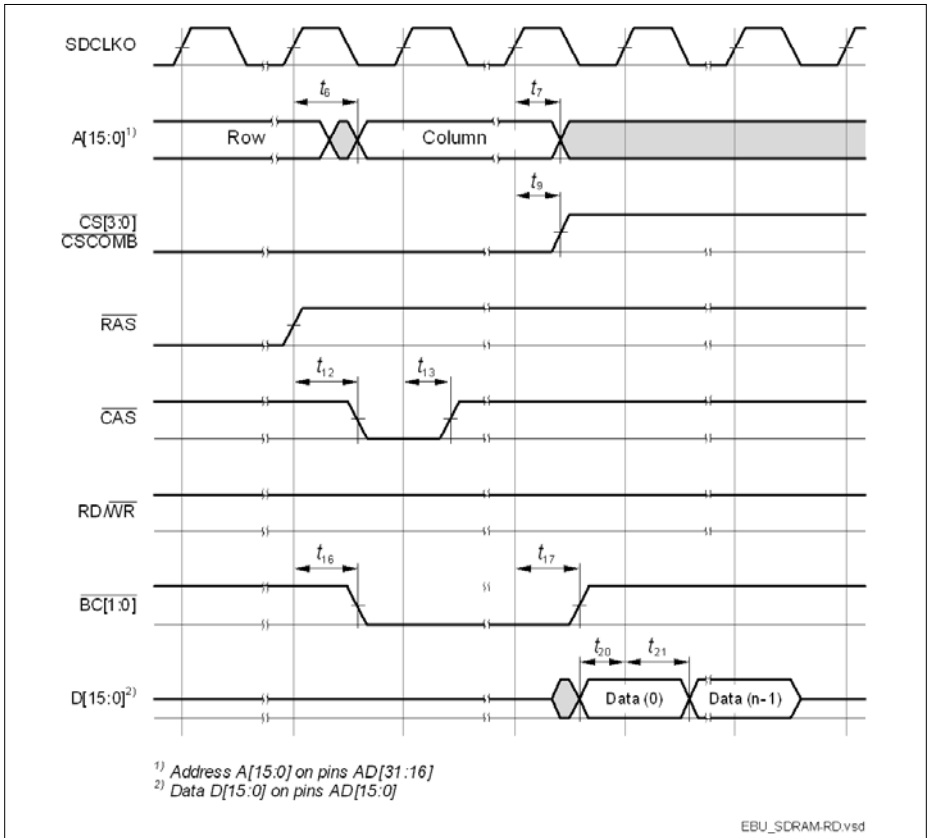

Figure 48 EBU SDRAM Read Access Timing

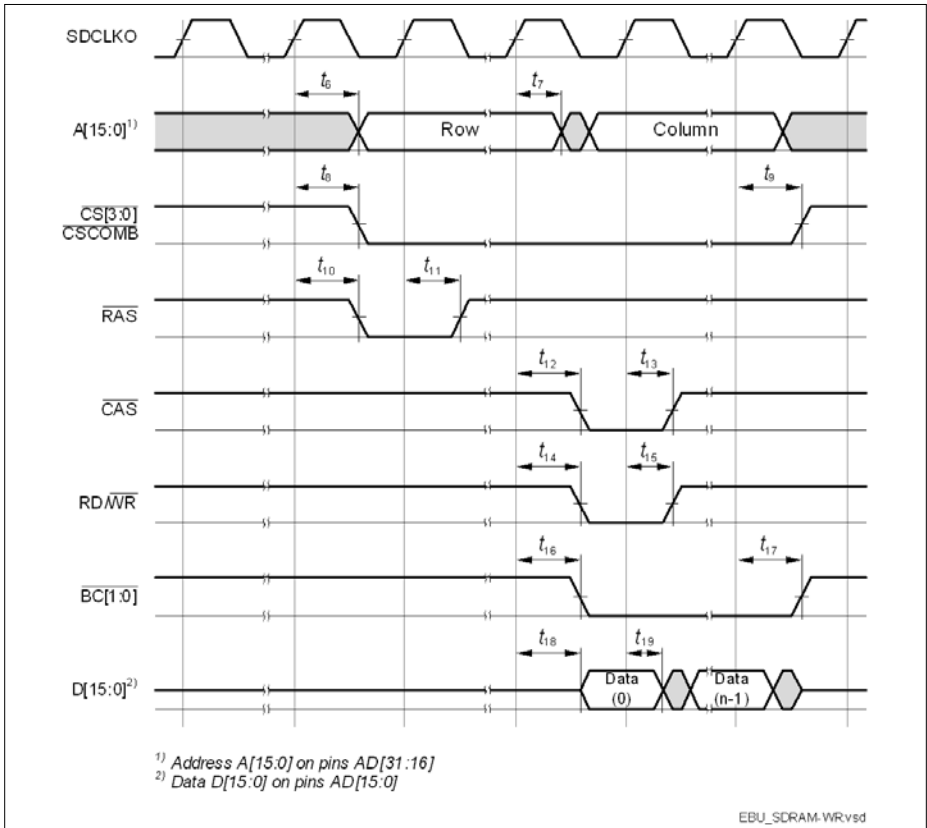

Figure 49 EBU SDRAM Write Access Timing

3.3.11 USB Interface Characteristics

The Universal Serial Bus (USB) Interface is compliant to the USB Rev. 2.0 Specification and the OTG Specification Rev. 1.3. High-Speed Mode is not supported.

Note: These parameters are not subject to production test, but verified by design and/or characterization.

Table 63 USB Timing Parameters (operating conditions apply)

Parameter	Symbol		Values			Unit	Note / Test Condition
			Min.	Typ.	Max.		
Rise time	t_R	CC	4	–	20	ns	$C_L = 50$ pF
Fall time	t_F	CC	4	–	20	ns	$C_L = 50$ pF
Rise/Fall time matching	t_R/t_F	CC	90	–	111.11	%	$C_L = 50$ pF
Crossover voltage	V_{CRS}	CC	1.3	–	2.0	V	$C_L = 50$ pF

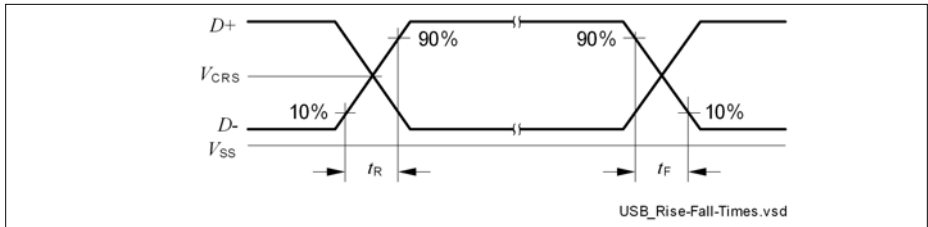

Figure 50 USB Signal Timing

3.3.12 Ethernet Interface (ETH) Characteristics

For proper operation of the Ethernet Interface it is required that $f_{SYS} \geq 100$ MHz.

Note: These parameters are not subject to production test, but verified by design and/or characterization.

3.3.12.1 ETH Measurement Reference Points

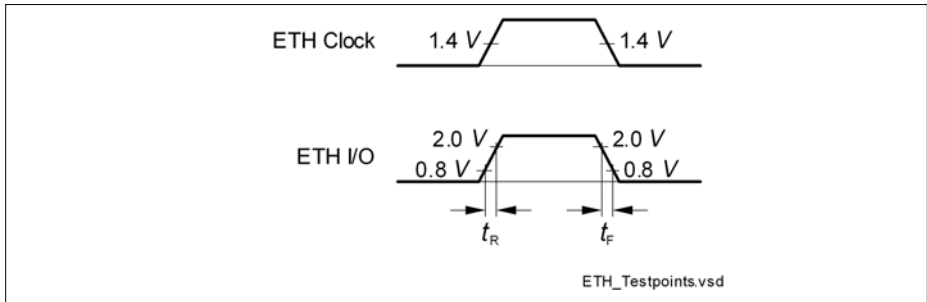

Figure 51 ETH Measurement Reference Points

3.3.12.2 ETH Management Signal Parameters (ETH_MDC, ETH_MDIO)

Table 64 ETH Management Signal Timing Parameters

Parameter	Symbol		Values			Unit	Note / Test Condition
			Min.	Typ.	Max.		
ETH_MDC period	t_1	CC	400	–	–	ns	$C_L = 25 \text{ pF}$
ETH_MDC high time	t_2	CC	160	–	–	ns	
ETH_MDC low time	t_3	CC	160	–	–	ns	
ETH_MDIO setup time (output)	t_4	CC	10	–	–	ns	
ETH_MDIO hold time (output)	t_5	CC	10	–	–	ns	
ETH_MDIO data valid (input)	t_6	SR	0	–	300	ns	

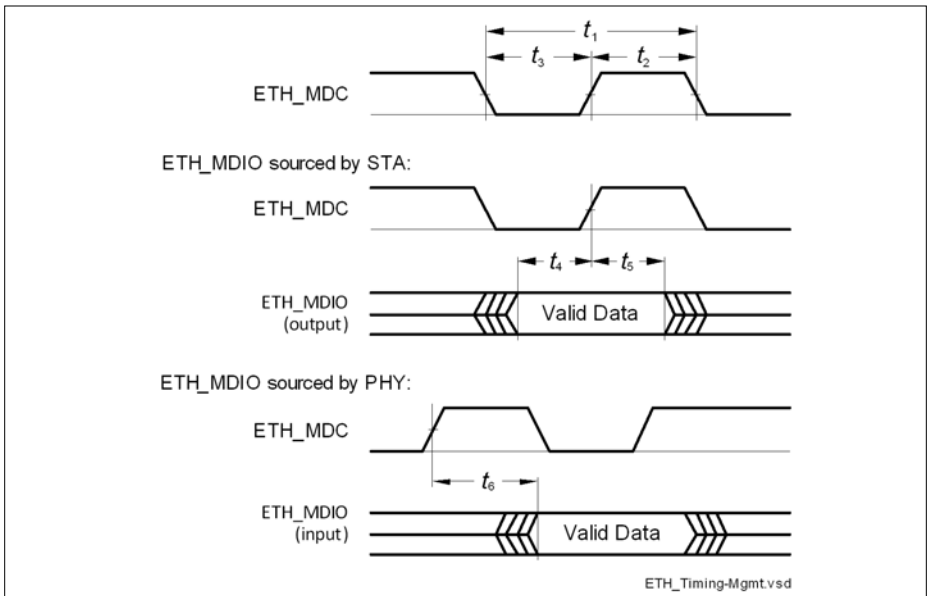

Figure 52 ETH Management Signal Timing

3.3.12.3 ETH MII Parameters

In the following, the parameters of the MII (Media Independent Interface) are described.

Table 65 ETH MII Signal Timing Parameters

Parameter	Symbol	SR	Values			Unit	Note / Test Condition
			Min.	Typ.	Max.		
Clock period, 10 Mbps	t_7	SR	400	–	–	ns	$C_L = 25 \text{ pF}$
Clock high time, 10 Mbps	t_8	SR	140	–	260	ns	
Clock low time, 10 Mbps	t_9	SR	140	–	260	ns	
Clock period, 100 Mbps	t_7	SR	40	–	–	ns	
Clock high time, 100 Mbps	t_8	SR	14	–	26	ns	
Clock low time, 100 Mbps	t_9	SR	14	–	26	ns	
Input setup time	t_{10}	SR	10	–	–	ns	
Input hold time	t_{11}	SR	10	–	–	ns	
Output valid time	t_{12}	CC	0	–	25	ns	

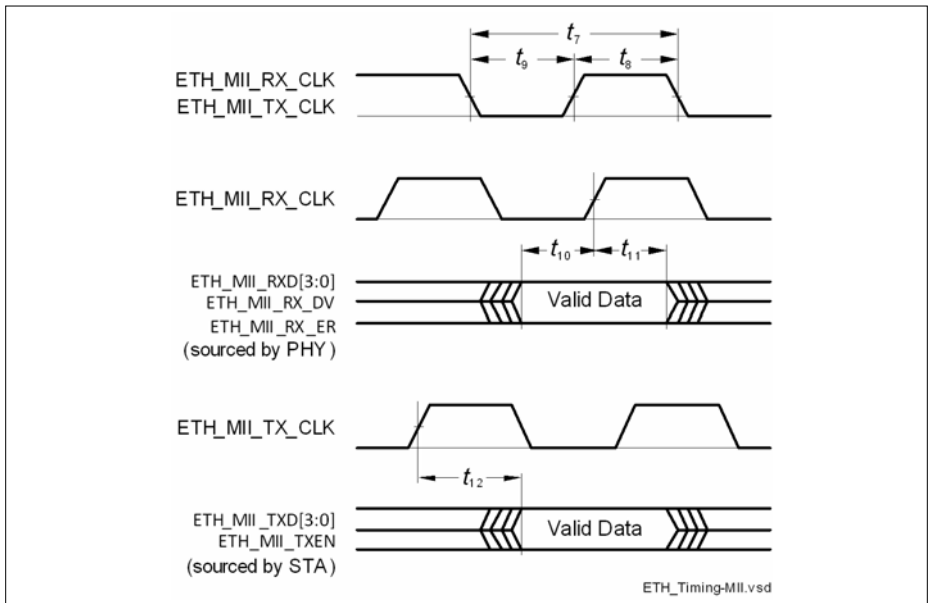

Figure 53 ETH MII Signal Timing

3.3.12.4 ETH RMII Parameters

In the following, the parameters of the RMII (Reduced Media Independent Interface) are described.

Table 66 ETH RMII Signal Timing Parameters

Parameter	Symbol		Values			Unit	Note / Test Condition
			Min.	Typ.	Max.		
ETH_RMII_REF_CL clock period	t_{13}	SR	20	–	–	ns	$C_L = 25 \text{ pF}$; 50 ppm
ETH_RMII_REF_CL clock high time	t_{14}	SR	7	–	13	ns	$C_L = 25 \text{ pF}$
ETH_RMII_REF_CL clock low time	t_{15}	SR	7	–	13	ns	
ETH_RMII_RXD[1:0], ETH_RMII_CRS setup time	t_{16}	SR	4	–	–	ns	
ETH_RMII_RXD[1:0], ETH_RMII_CRS hold time	t_{17}	SR	2	–	–	ns	
ETH_RMII_TXD[1:0], ETH_RMII_TXEN data valid	t_{18}	CC	4	–	15	ns	

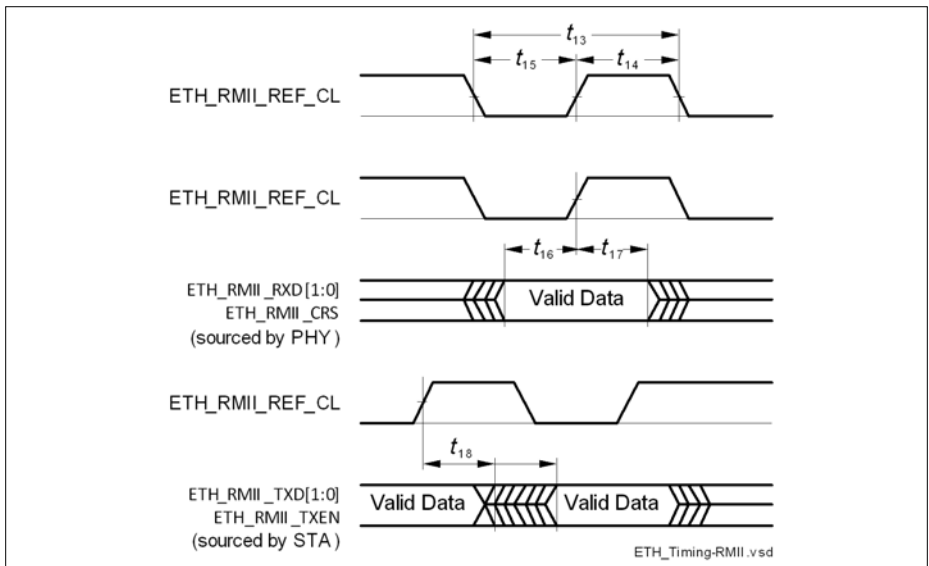

Figure 54 ETH RMII Signal Timing

3.3.13 EtherCAT (ECAT) Characteristics

3.3.13.1 ECAT Measurement Reference Points

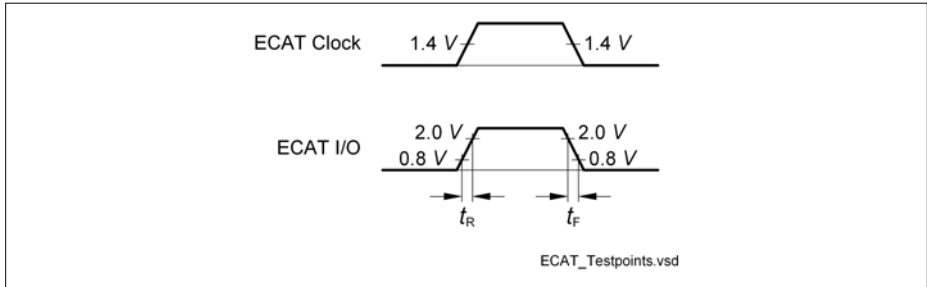

Figure 55 Measurement Reference Points

3.3.13.2 ETH Management Signal Parameters (MCLK, MDIO)

Table 67 ECAT Management Signal Timing Parameters

Parameter	Symbol	Values			Unit	Note / Test Condition
		Min.	Typ.	Max.		
ECAT_MCLK period	t_{MCLK_CC}	–	400	–	ns	IEEE802.3 requirement (2.5 MHz) $C_L = 25$ pF
ECAT_MCLK high time	$t_{MCLK_h_CC}$	160	–	–	ns	
ECAT_MCLK low time	$t_{MCLK_l_CC}$	160	–	–	ns	
ECAT_MDIO setup time (output)	$t_{D_setup_CC}$	10	–	–	ns	
ECAT_MDIO hold time (output)	$t_{D_hold_CC}$	10	–	–	ns	
ECAT_MDIO data valid (input)	$t_{D_valid_SR}$	0	–	300	ns	

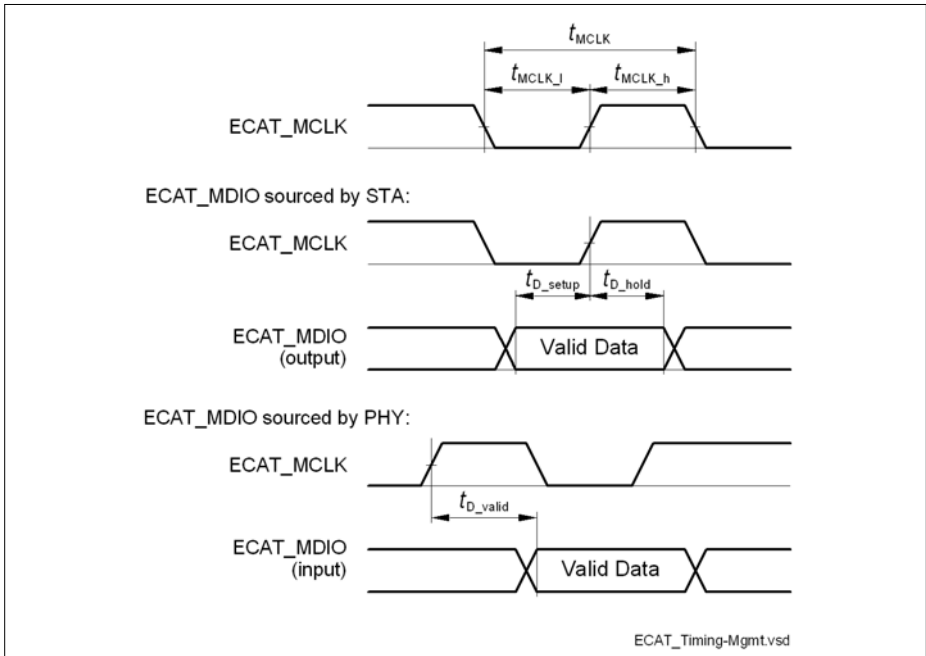

Figure 56 ECAT Management Signal Timing

3.3.13.3 MII Timing TX Characteristics

Table 68 ETH MII TX Signal Timing Parameters

Parameter	Symbol	Values			Unit	Note / Test Condition
		Min.	Typ.	Max.		
PHY_CLK25, TX_CLK period	t_{TX_CLK} SR	–	40	–	ns	
Delay between PHY clock source PHY_CLK25 and TX_CLK output of the PHY	t_{PHY_delay} SR	–	–	–	ns	PHY dependent

Table 68 ETH MII TX Signal Timing Parameters (cont'd)

Parameter	Symbol	Values			Unit	Note / Test Condition
		Min.	Typ.	Max.		
PHY setup requirement: TXEN/TXD[3:0] with respect to TX_CLK	t_{TX_setup} SR	15	–	0	ns	PHY dependent IEEE802.3 limit is 15 ns
PHY hold requirement: TXEN/TXD[3:0] with respect to TX_CLK	t_{TX_hold} CC	0	–	25	ns	PHY dependent IEEE802.3 limit is 0 ns

Note: ECAT0_CONPx.TX_SHIFT can be adjusted by displaying TX_CLK of a PHY and TXEN/TXD[3:0] on an oscilloscope. TXEN/TXD[3:0] is allowed to change between 0 ns and 25 ns after a rising edge of TX_CLK (according to IEEE802.3 – check your PHY's documentation). Configure TX_SHIFT so that TXEN/TXD[3:0] change near the middle of this range. It is sufficient to check just one of the TXEN/TXD[3:0] signals, because they are nearly generated at the same time.

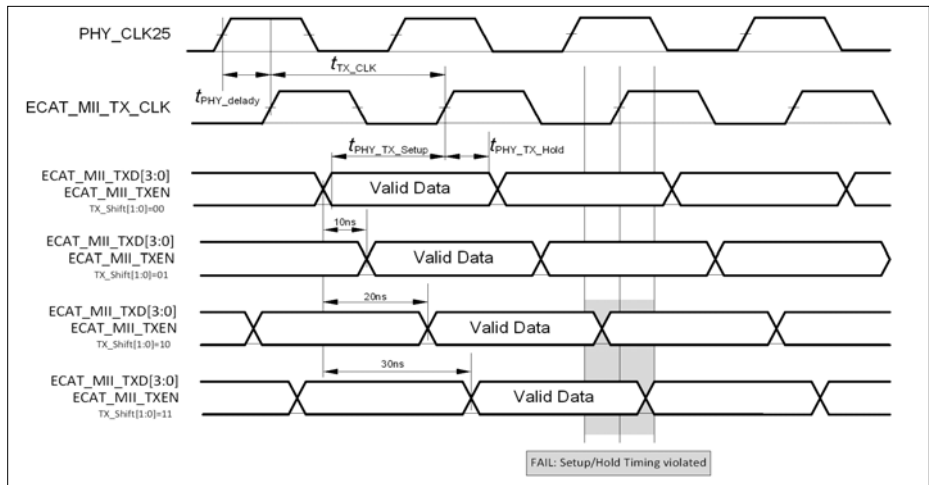

Figure 57 MII TX Characteristics

3.3.13.4 MII Timing RX Characteristics

Table 69 ETH MII RX Signal Timing Parameters

Parameter	Symbol	Values			Unit	Note / Test Condition
		Min.	Typ.	Max.		
RX_CLK period	t_{RX_CLK} SR	–	40	–	ns	$C_L = 25\text{ pF}$, IEEE802.3 requirement
RX_DV/RX_DV/RXD[3:0] valid before rising edge of RX_CLK	t_{RX_setup} SR	10	–	–	ns	
RX_DV/RX_DV/RXD[3:0] valid after rising edge of RX_CLK	t_{RX_hold} SR	10	–	–	ns	

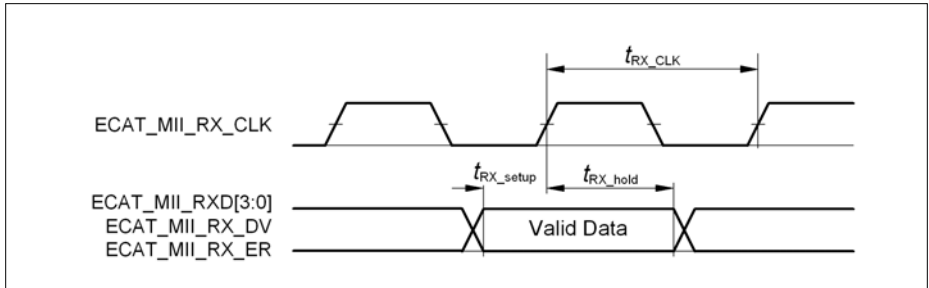

Figure 58 MII RX characteristics

3.3.13.5 Sync/Latch Timings

Table 70 Sync/Latch Timings

Parameter	Symbol	Values			Unit	Note / Test Condition
		Min.	Typ.	Max.		
SYNC0/1	$t_{DC_SYNC_Jitter}$ SR	–	–	11 + m ¹⁾	ns	
LATCH0/1	t_{DC_LATCH} SR	12 + n ²⁾	–	–	ns	

- 1) additional delay form logic and pad, number is added after characterization
- 2) additional shaping delay, number is added after characterization

Note: SYNC0/1 pulse length are initially loaded by EEPROM content ADR 0x0002. The actual used value can be read back from Register DC_PULSE_LEN.

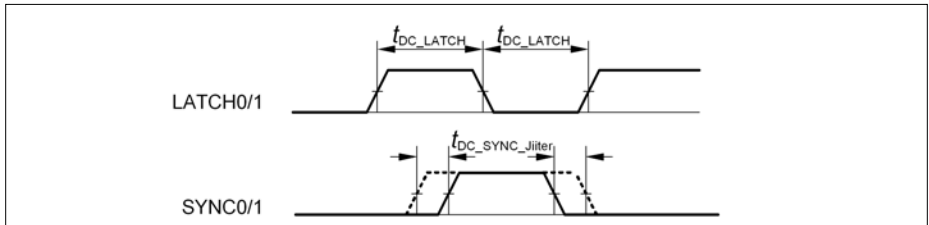

Figure 59 Sync/Latch Timings

4 Package and Reliability

The XMC4[78]00 is a member of the XMC4000 Family of microcontrollers. It is also compatible to a certain extent with members of similar families or subfamilies.

Each package is optimized for the device it houses. Therefore, there may be slight differences between packages of the same pin-count but for different device types. In particular, the size of the Exposed Die Pad may vary.

If different device types are considered or planned for an application, it must be ensured that the board layout fits all packages under consideration.

4.1 Package Parameters

Table 71 provides the thermal characteristics of the packages used in XMC4[78]00.

Table 71 Thermal Characteristics of the Packages

Parameter	Symbol	Limit Values		Unit	Package Types
		Min.	Max.		
Exposed Die Pad dimensions including U-Groove	$E_x \times E_y$ CC	–	7.0 × 7.0	mm	PG-LQFP-144-24 PG-LQFP-100-25
Exposed Die Pad dimensions excluding U-Groove	$A_x \times A_y$ CC	–	6.2 × 6.2	mm	PG-LQFP-144-24 PG-LQFP-100-25
Exposed Die Pad dimensions	–	–	7.0 × 7.0	mm	PG-LQFP-144-28 PG-LQFP-100-29
Thermal resistance Junction-Ambient $T_J \leq 150\text{ °C}$	$R_{\Theta JA}$ CC	–	27.0	K/W	PG-LFBGA-196-2
		–	19.5	K/W	PG-LQFP-144-24 ¹⁾ PG-LQFP-144-28 ¹⁾
		–	22.5	K/W	PG-LQFP-100-25 ¹⁾ PG-LQFP-100-29 ¹⁾

1) Device mounted on a 4-layer JEDEC board (JESD 51-7) with thermal vias; exposed pad soldered.

Note: For electrical reasons, it is required to connect the exposed pad to the board ground V_{SS} , independent of EMC and thermal requirements.

4.1.1 Thermal Considerations

When operating the XMC4[78]00 in a system, the total heat generated in the chip must be dissipated to the ambient environment to prevent overheating and the resulting thermal damage.

The maximum heat that can be dissipated depends on the package and its integration into the target board. The “Thermal resistance $R_{\Theta JA}$ ” quantifies these parameters. The power dissipation must be limited so that the average junction temperature does not exceed 150 °C.

The difference between junction temperature and ambient temperature is determined by $\Delta T = (P_{INT} + P_{IOSTAT} + P_{IODYN}) \times R_{\Theta JA}$

The internal power consumption is defined as

$$P_{INT} = V_{DDP} \times I_{DDP} \text{ (switching current and leakage current).}$$

The static external power consumption caused by the output drivers is defined as

$$P_{IOSTAT} = \Sigma((V_{DDP} - V_{OH}) \times I_{OH}) + \Sigma(V_{OL} \times I_{OL})$$

The dynamic external power consumption caused by the output drivers (P_{IODYN}) depends on the capacitive load connected to the respective pins and their switching frequencies.

If the total power dissipation for a given system configuration exceeds the defined limit, countermeasures must be taken to ensure proper system operation:

- Reduce V_{DDP} , if possible in the system
- Reduce the system frequency
- Reduce the number of output pins
- Reduce the load on active output drivers

4.2 Package Outlines

The availability of different packages for different devices types is listed in **Table 1**.

The exposed die pad dimensions are listed in **Table 71**.

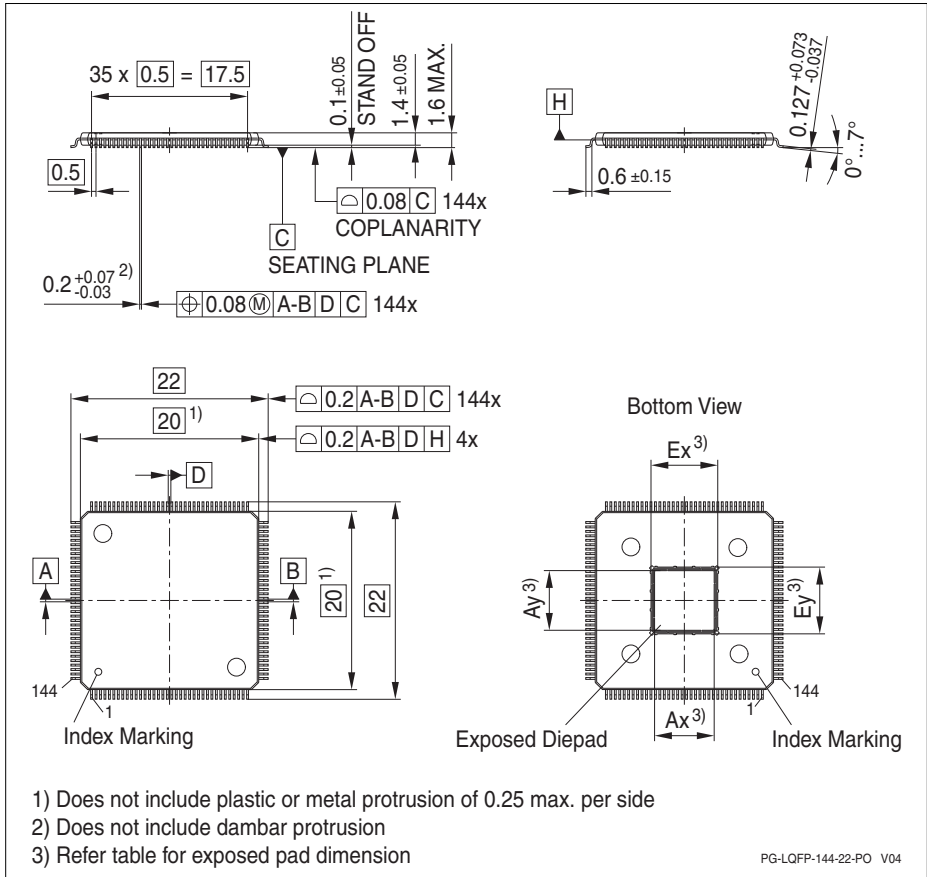

Figure 60 PG-LQFP-144-24 (Plastic Green Low Profile Quad Flat Package)

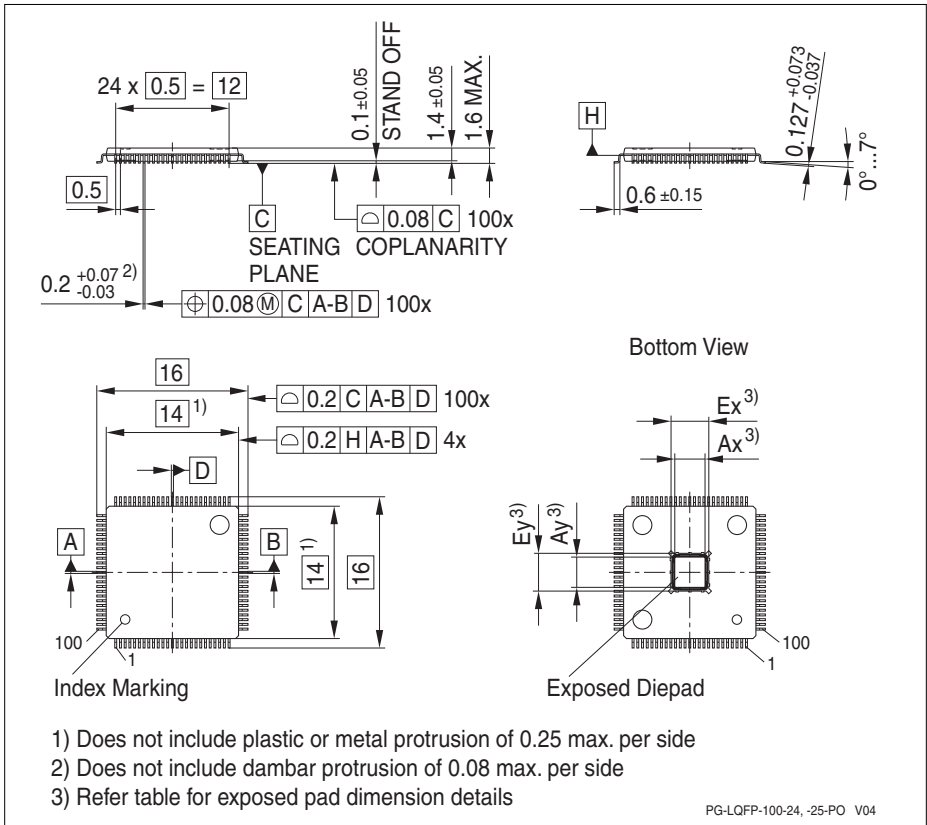

Figure 62 PG-LQFP-100-25 (Plastic Green Low Profile Quad Flat Package)

All dimensions in mm.

You can find complete information about Infineon packages, packing and marking in our Infineon Internet Page "Packages": <http://www.infineon.com/packages>.

5 Quality Declarations

The qualification of the XMC4[78]00 is executed according to the JEDEC standard JESD471.

Note: For automotive applications refer to the Infineon automotive microcontrollers.

Table 72 Quality Parameters

Parameter	Symbol	Values			Unit	Note / Test Condition
		Min.	Typ.	Max.		
Operation lifetime	t_{OP} CC	20	–	–	a	$T_J \leq 109^\circ\text{C}$, device permanent on
ESD susceptibility according to Human Body Model (HBM)	V_{HBM} SR	–	–	3 000	V	EIA/JESD22-A114-B
ESD susceptibility according to Charged Device Model (CDM)	V_{CDM} SR	–	–	1 000	V	Conforming to JESD22-C101-C
Moisture sensitivity level	MSL CC	–	–	3	–	JEDEC J-STD-020D
Soldering temperature	T_{SDR} SR	–	–	260	$^\circ\text{C}$	Profile according to JEDEC J-STD-020D

www.infineon.com

Published by Infineon Technologies AG